

191 Roope Road

SUBMITTED BY
Ray White Rockhampton Casey
stockers@cqoz.com

CREATED ON
2022-08-29

Floors
2

▼ Ground Floor

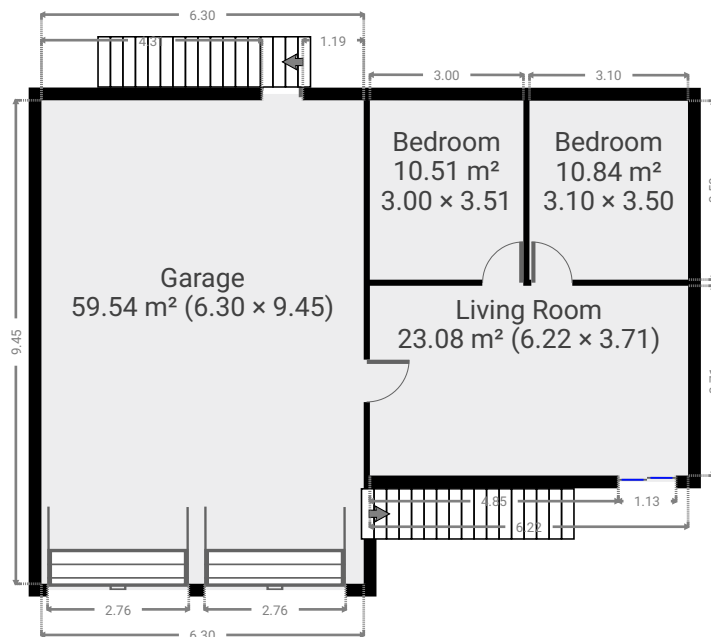
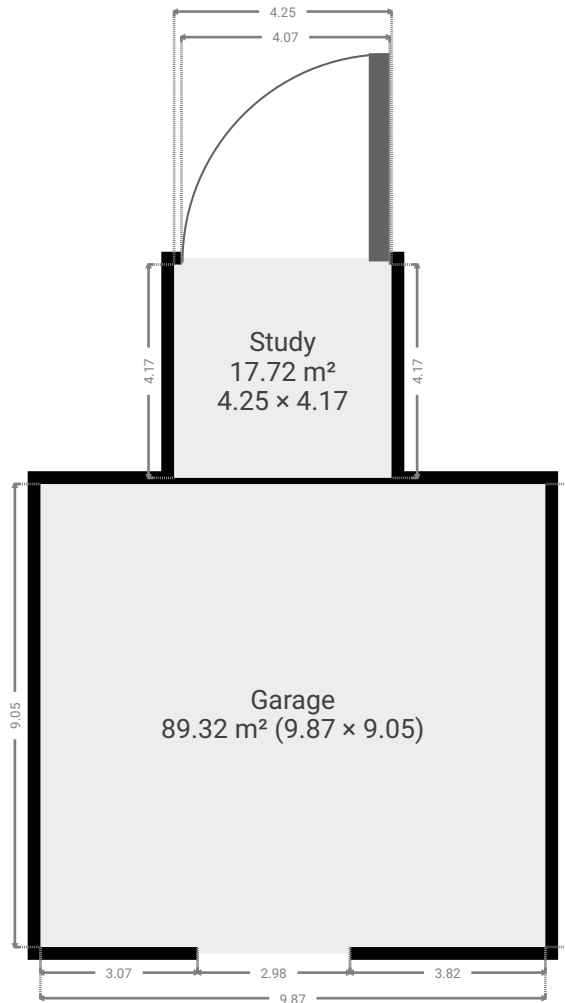

▼ **Bedroom**
Ground Floor

WIDTH: 3.00 m • LENGTH: 3.51 m
AREA: 10.51 m² • PERIMETER: 13.01 m

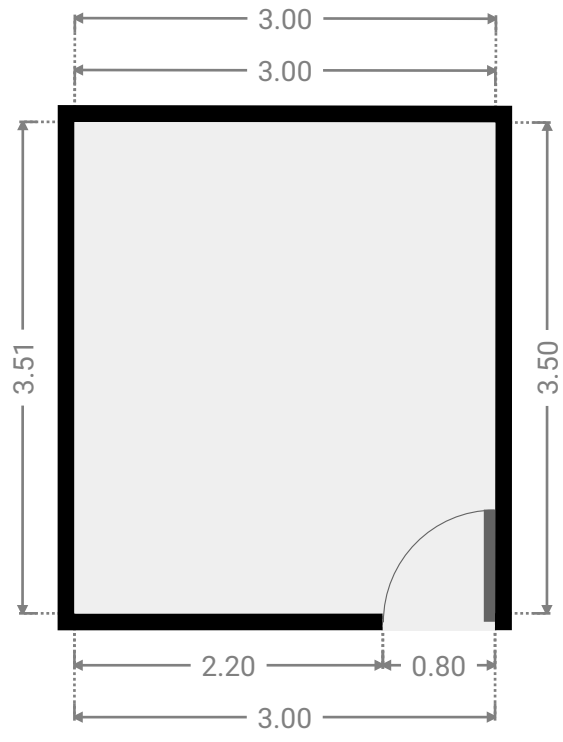
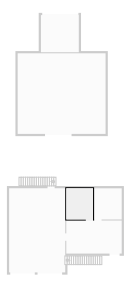

▼ **Bedroom**
Ground Floor

WIDTH: 3.10 m • LENGTH: 3.50 m
AREA: 10.84 m² • PERIMETER: 13.19 m

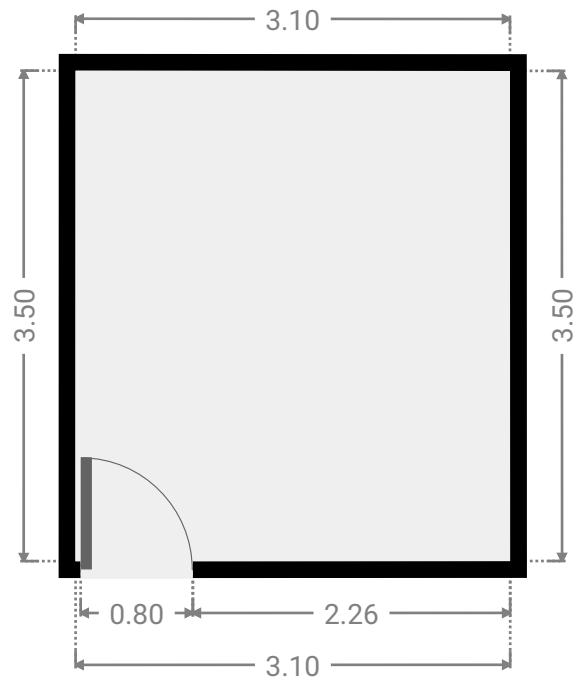
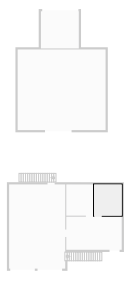

▼ **Garage**
Ground Floor

WIDTH: 6.30 m • LENGTH: 9.45 m
AREA: 59.54 m² • PERIMETER: 31.50 m

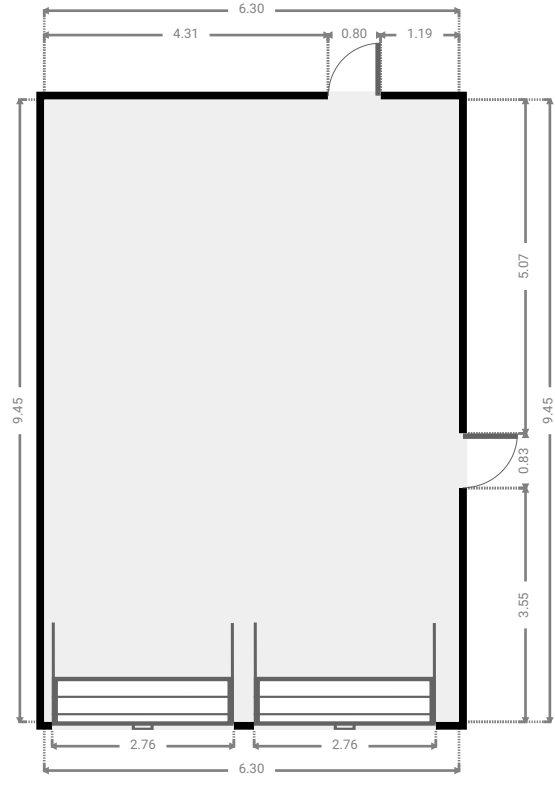
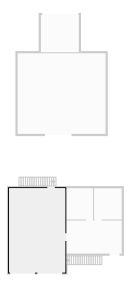

▼ **Garage**
Ground Floor

WIDTH: 9.87 m • LENGTH: 9.05 m
AREA: 89.32 m² • PERIMETER: 37.84 m

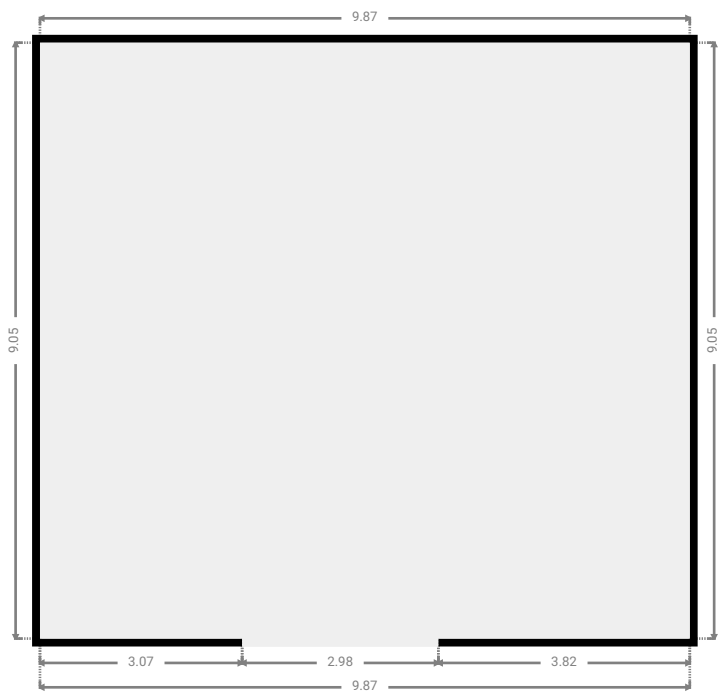
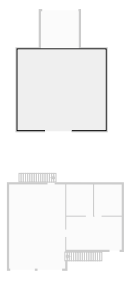

▼ **Living Room**
Ground Floor

WIDTH: 6.22 m • LENGTH: 3.71 m
AREA: 23.08 m² • PERIMETER: 19.86 m

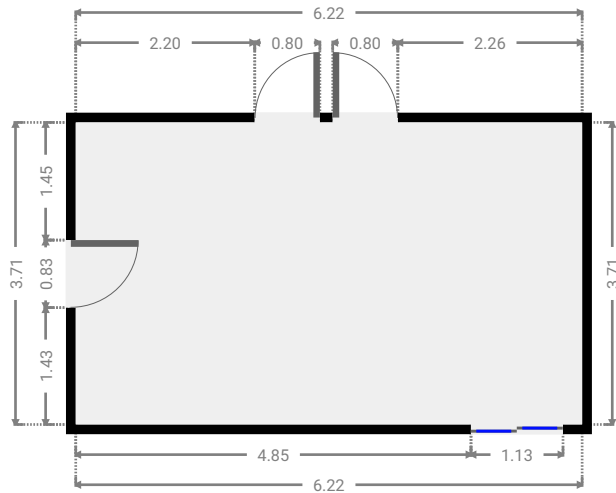
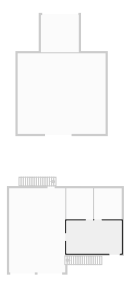

▼ **Study**
Ground Floor

WIDTH: 4.25 m • LENGTH: 4.17 m
AREA: 17.72 m² • PERIMETER: 16.84 m

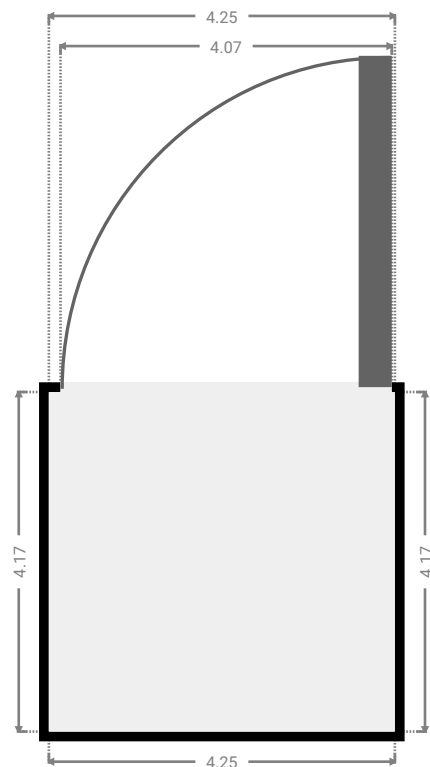
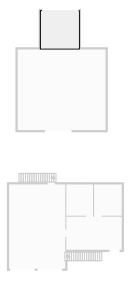

▼ 1st Floor

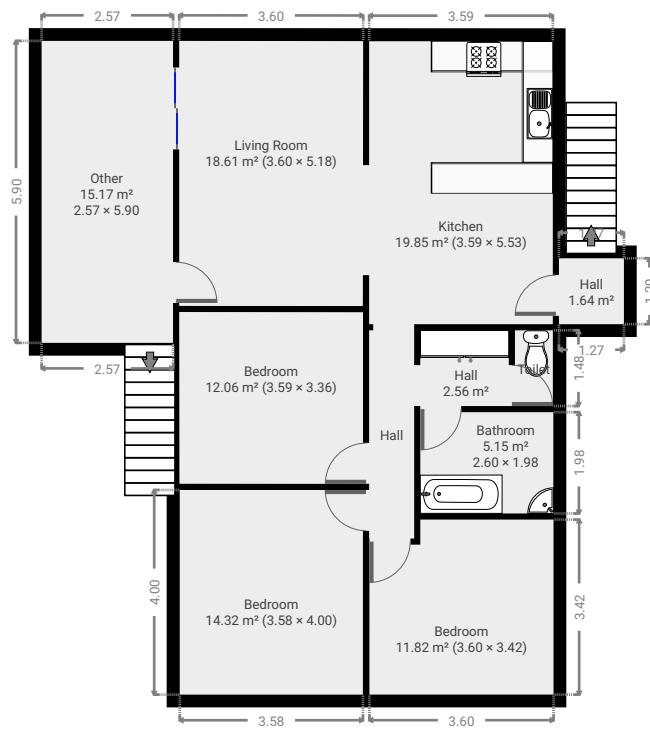

▼ **Bathroom**
1st Floor

WIDTH: 1.98 m • LENGTH: 2.60 m
AREA: 5.15 m² • PERIMETER: 9.16 m

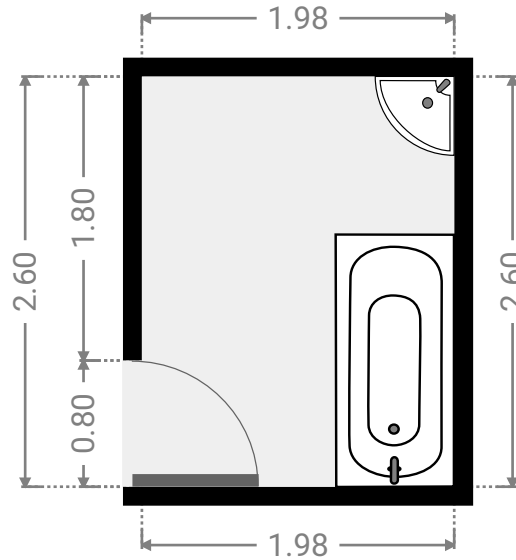
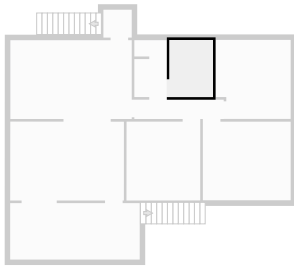

▼ **Bedroom**
1st Floor

WIDTH: 3.42 m • LENGTH: 3.60 m
AREA: 11.82 m² • PERIMETER: 14.04 m

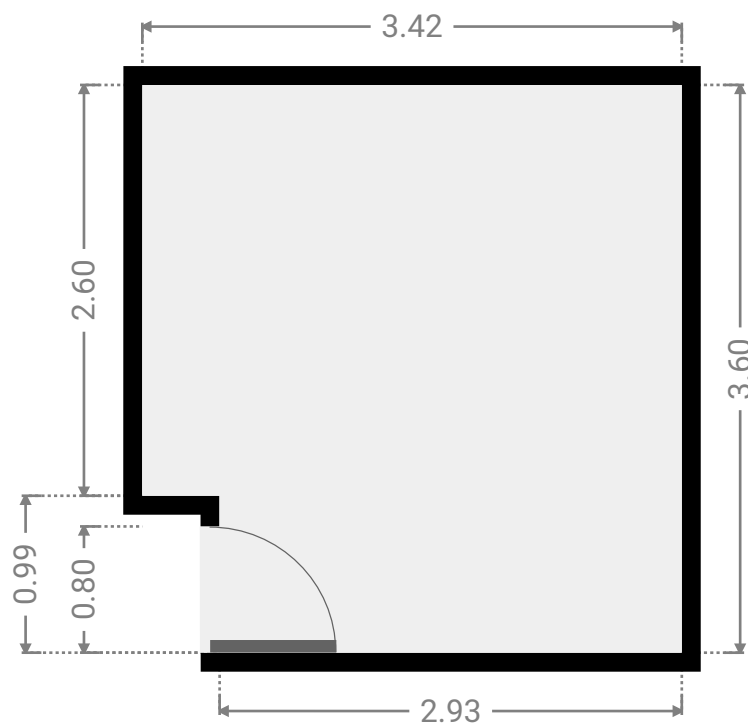
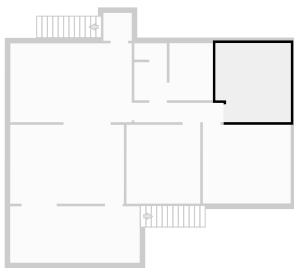

▼ **Bedroom**
1st Floor

WIDTH: 4.00 m • LENGTH: 3.58 m
AREA: 14.32 m² • PERIMETER: 15.16 m

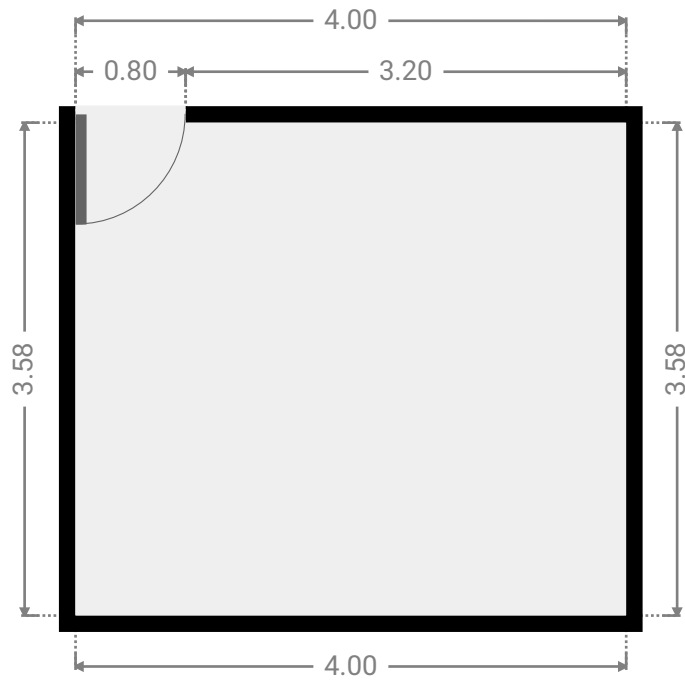
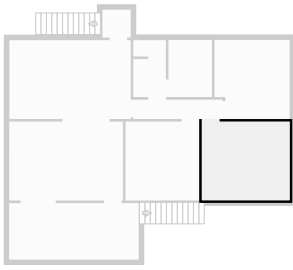

▼ **Bedroom**
1st Floor

WIDTH: 3.36 m • LENGTH: 3.59 m
AREA: 12.06 m² • PERIMETER: 13.90 m

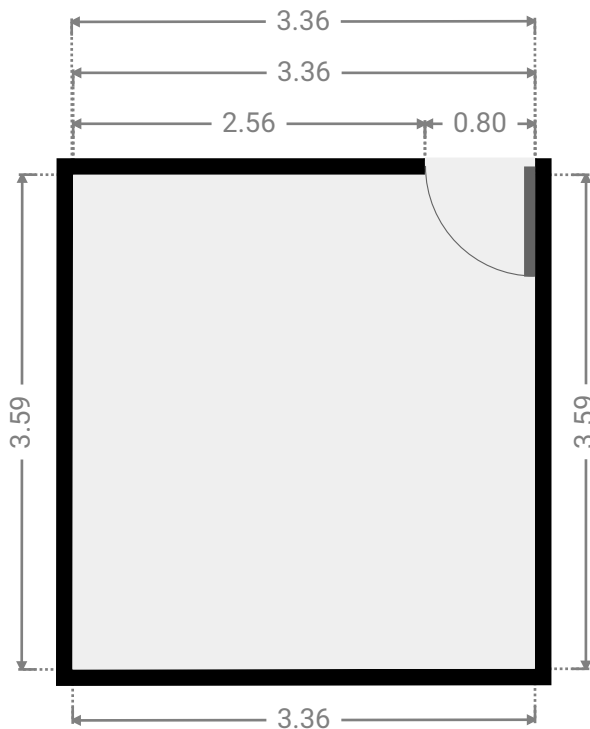
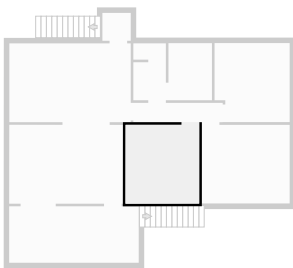

▼ **Hall**
1st Floor

WIDTH: 4.07 m • LENGTH: 0.88 m
AREA: 3.58 m² • PERIMETER: 9.90 m

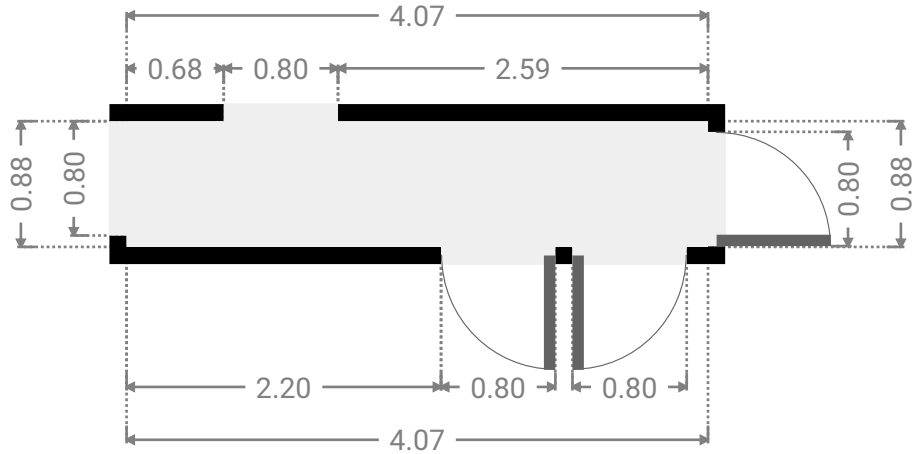

▼ **Hall**
1st Floor

WIDTH: 1.48 m • LENGTH: 1.73 m
AREA: 2.56 m² • PERIMETER: 6.42 m

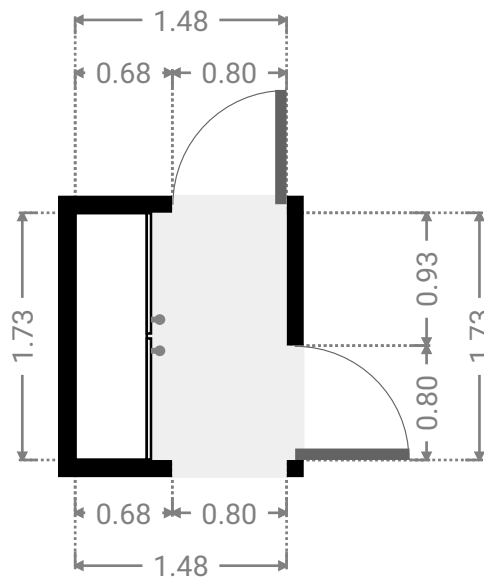
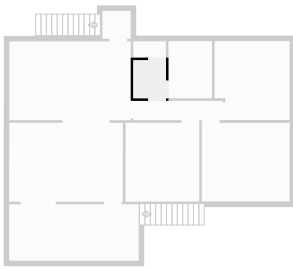

▼ **Hall**
1st Floor

WIDTH: 1.29 m • LENGTH: 1.27 m
AREA: 1.64 m² • PERIMETER: 5.12 m

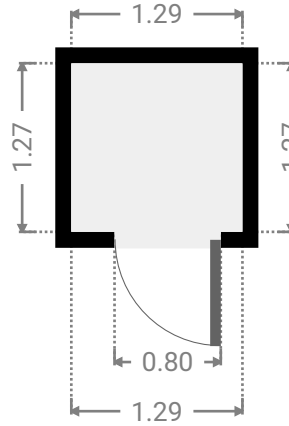
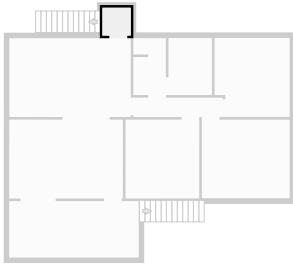

▼ **Kitchen**
1st Floor

WIDTH: 5.53 m • LENGTH: 3.59 m
AREA: 19.85 m² • PERIMETER: 18.24 m

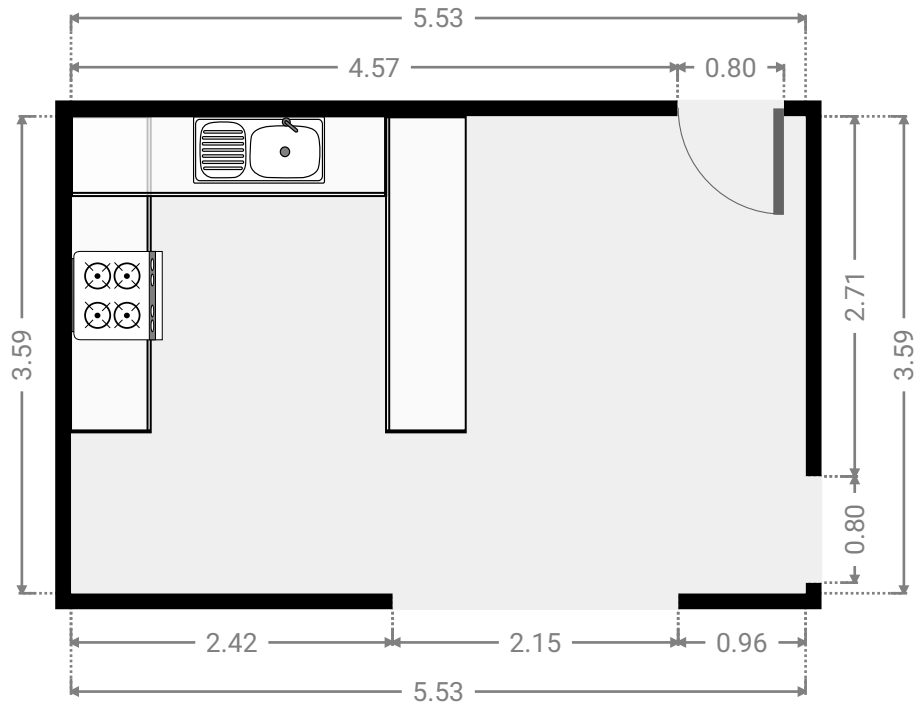
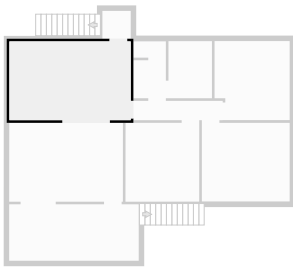

▼ **Living Room**
1st Floor

WIDTH: 5.18 m • LENGTH: 3.60 m
AREA: 18.61 m² • PERIMETER: 17.54 m

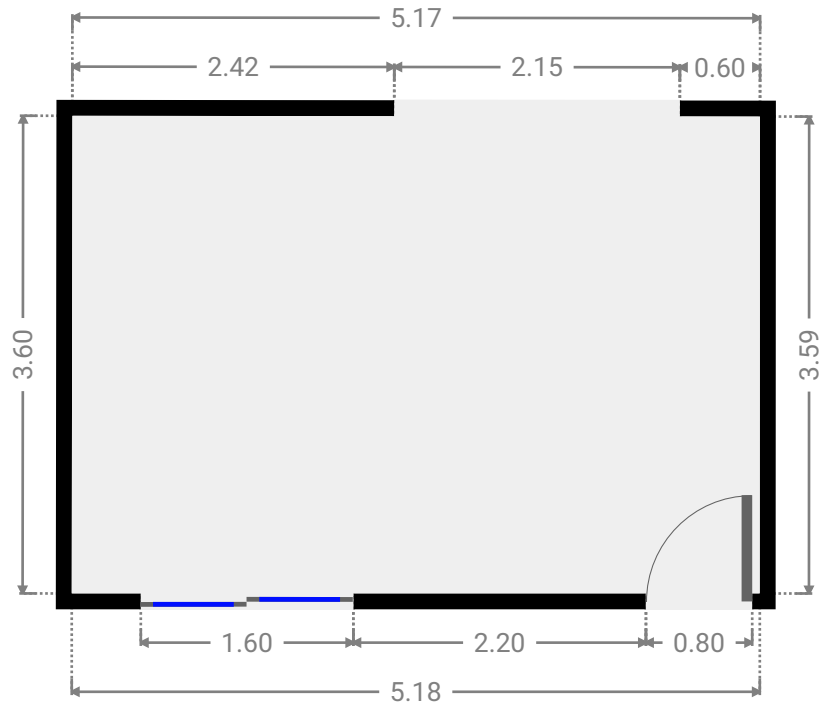
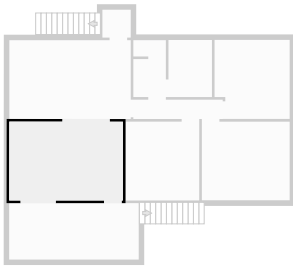

▼ **Other**
1st Floor

WIDTH: 5.90 m • LENGTH: 2.57 m
AREA: 15.17 m² • PERIMETER: 16.94 m

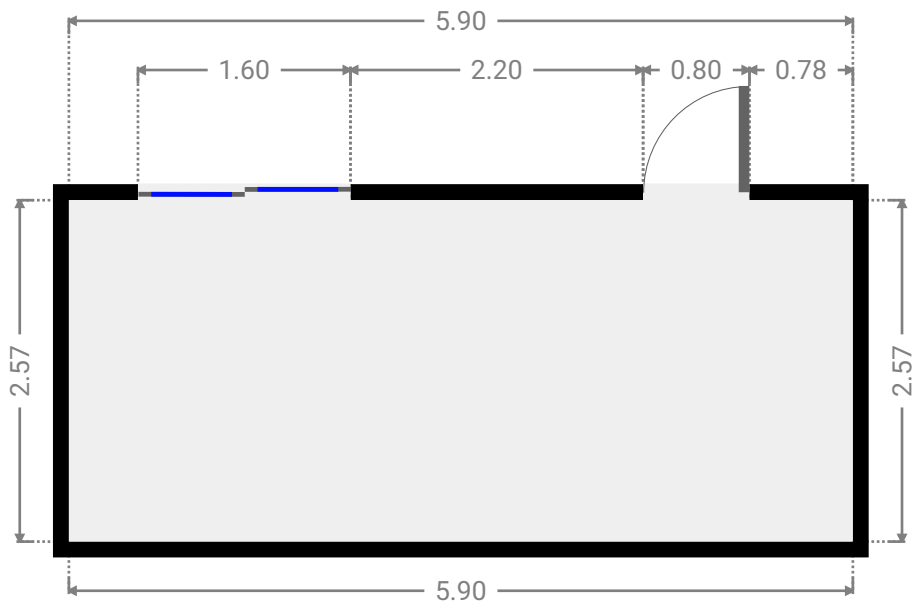
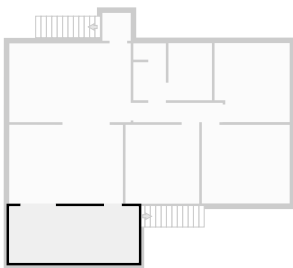

▼ Toilet
1st Floor

WIDTH: 1.48 m • LENGTH: 0.74 m
AREA: 1.10 m² • PERIMETER: 4.44 m

