

189 Wilson Street

Created on
2019-05-09

Floors
2

▼ Ground Floor

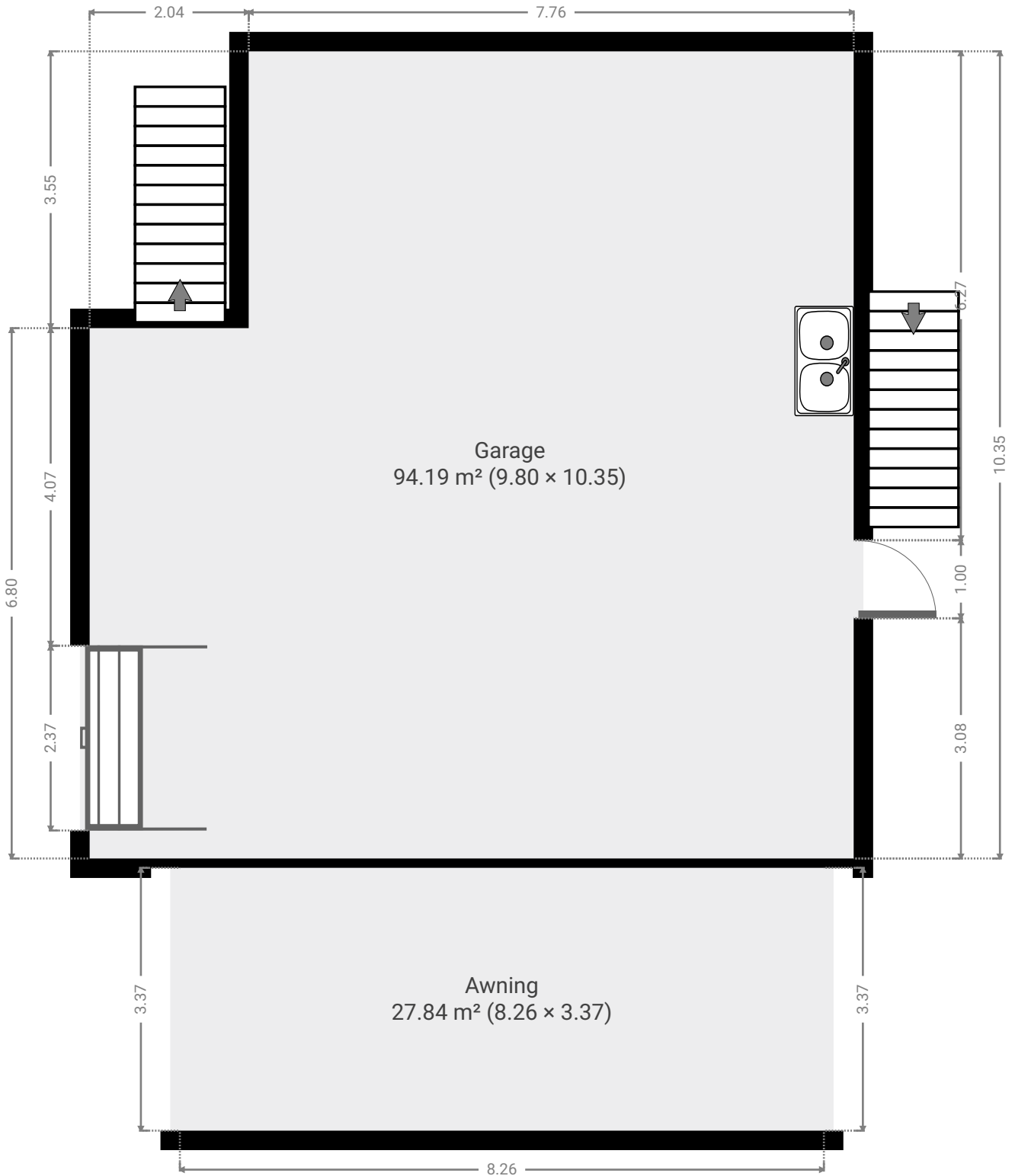

▼ **Garage**
Ground Floor

WIDTH: 10.35 m • LENGTH: 9.80 m
AREA: 94.19 m² • PERIMETER: 40.30 m

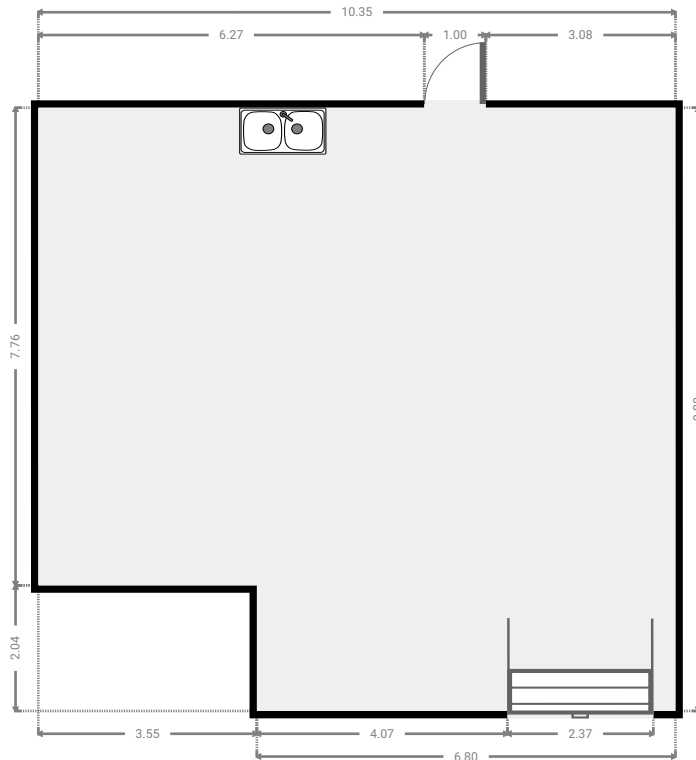
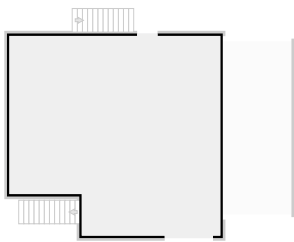

▼ **Awning**
Ground Floor

WIDTH: 3.37 m • LENGTH: 8.26 m
AREA: 27.84 m² • PERIMETER: 23.26 m

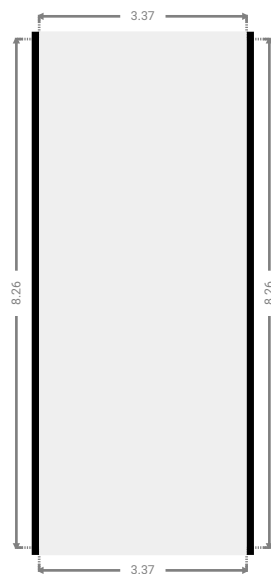

▼ 1st Floor

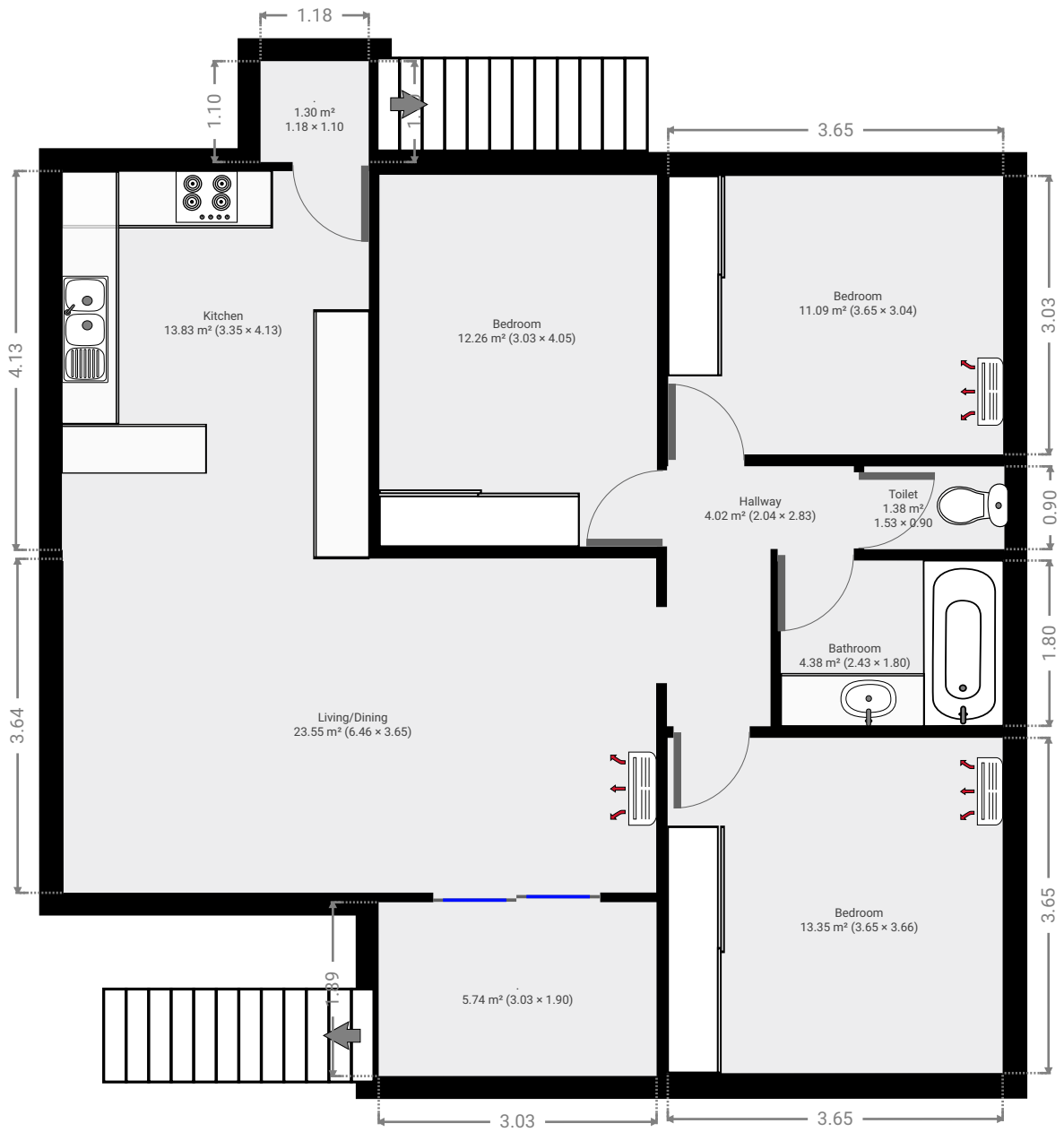

▼ Living/Dining
1st Floor

WIDTH: 6.46 m • LENGTH: 3.65 m
AREA: 23.55 m² • PERIMETER: 20.21 m

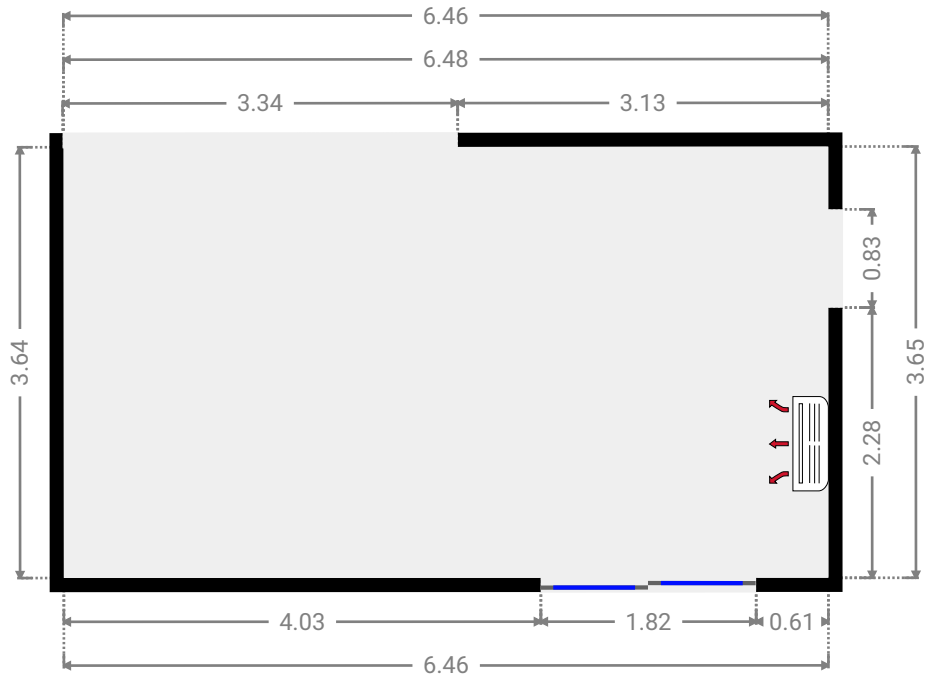
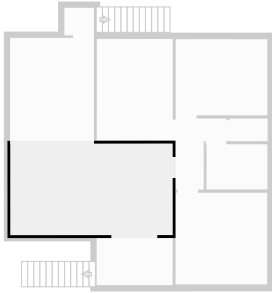

▼ Kitchen
1st Floor

WIDTH: 3.35 m • LENGTH: 4.13 m
AREA: 13.83 m² • PERIMETER: 14.96 m

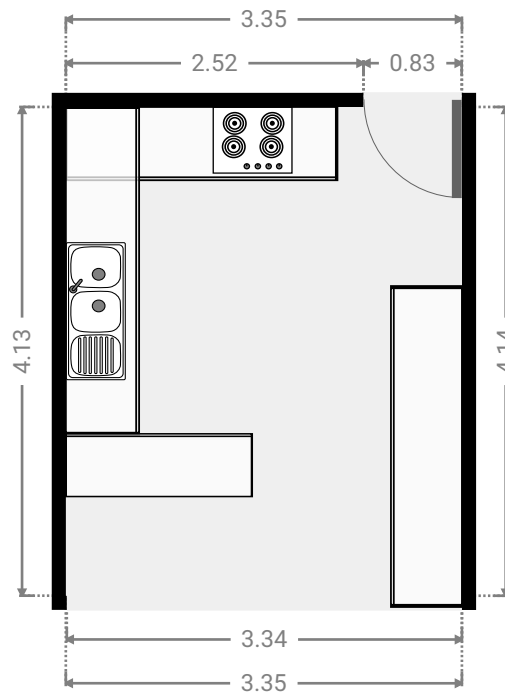
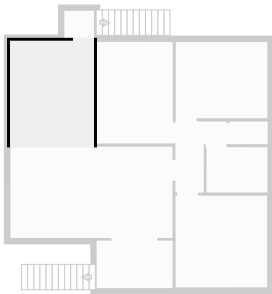

▼ **Hallway**
1st Floor

WIDTH: 2.04 m • LENGTH: 2.83 m
AREA: 4.02 m² • PERIMETER: 9.74 m

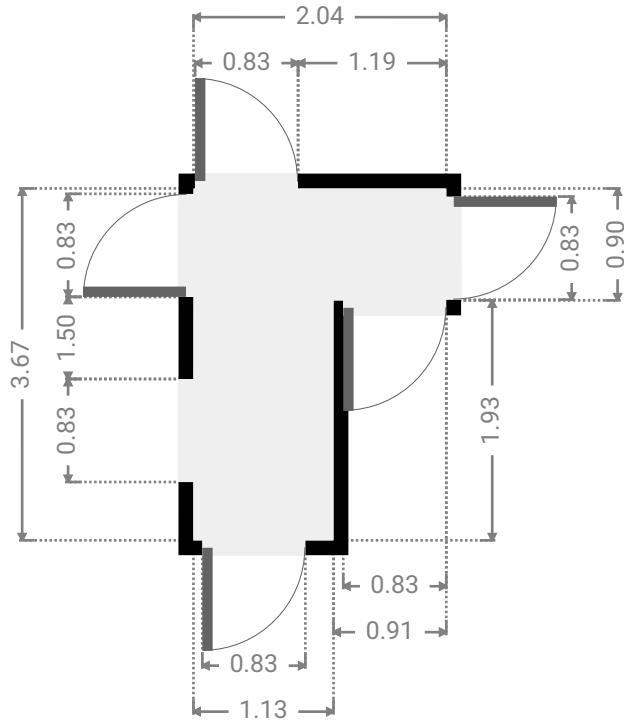
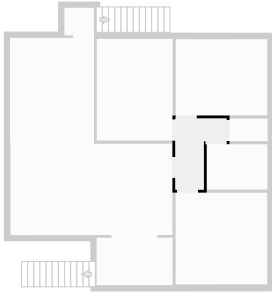

▼ **Bedroom**
1st Floor

WIDTH: 3.65 m • LENGTH: 3.04 m
AREA: 11.09 m² • PERIMETER: 13.38 m

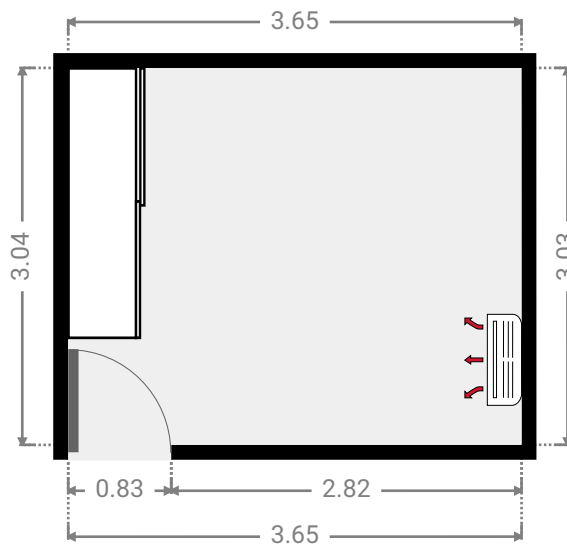
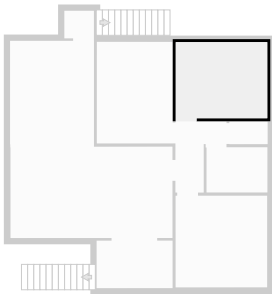

▼ **Toilet**
1st Floor

WIDTH: 1.53 m • LENGTH: 0.90 m
AREA: 1.38 m² • PERIMETER: 4.86 m

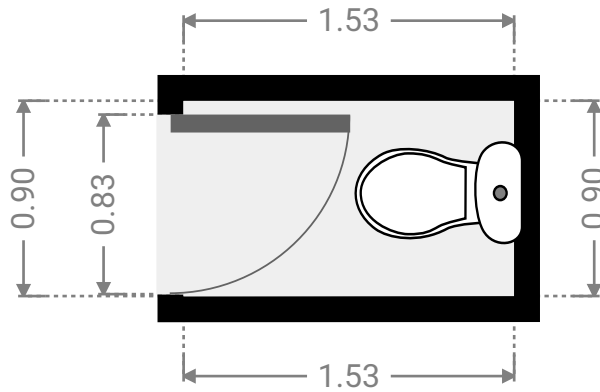
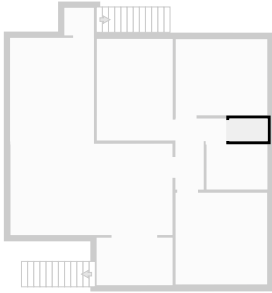

▼ **Bathroom**
1st Floor

WIDTH: 2.43 m • LENGTH: 1.80 m
AREA: 4.38 m² • PERIMETER: 8.46 m

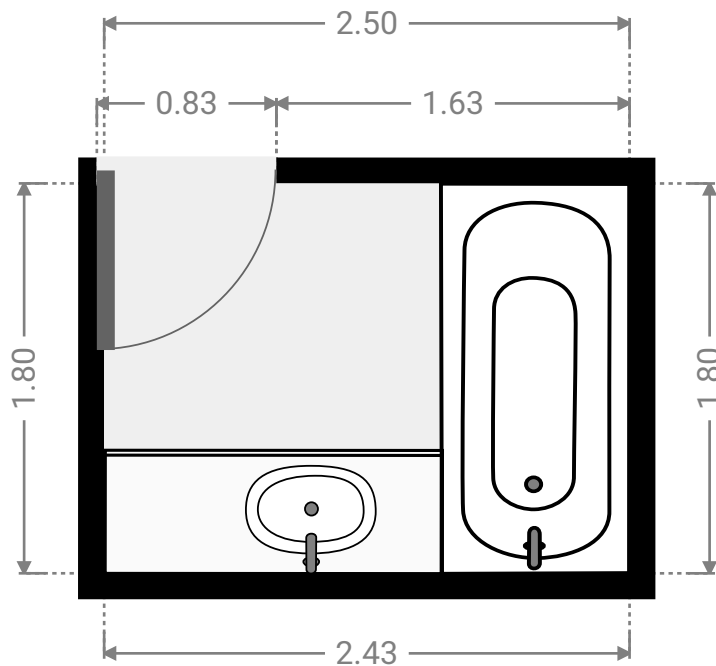
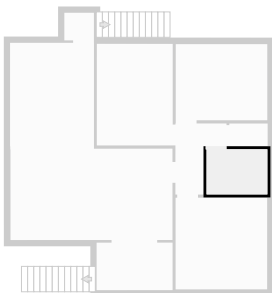

▼ **Bedroom**
1st Floor

WIDTH: 3.03 m • LENGTH: 4.05 m
AREA: 12.26 m² • PERIMETER: 14.16 m

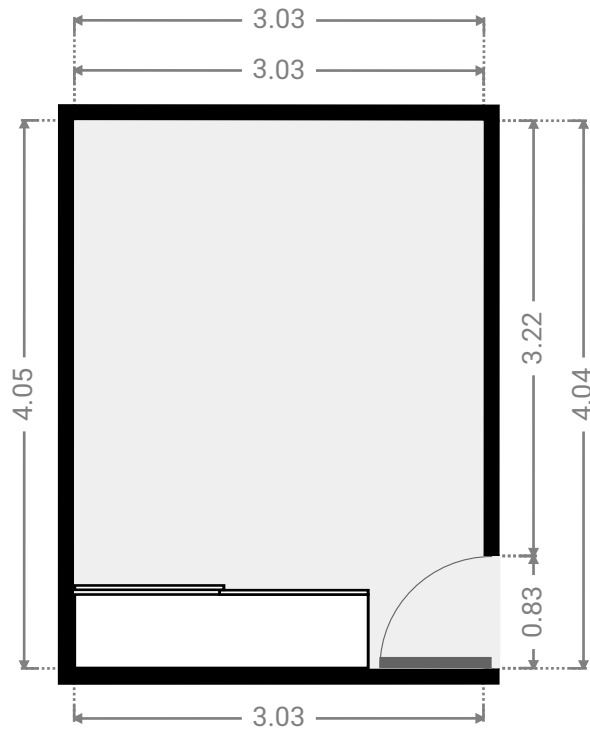
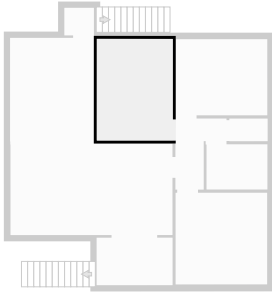

▼ **Bedroom**
1st Floor

WIDTH: 3.65 m • LENGTH: 3.66 m
AREA: 13.35 m² • PERIMETER: 14.62 m

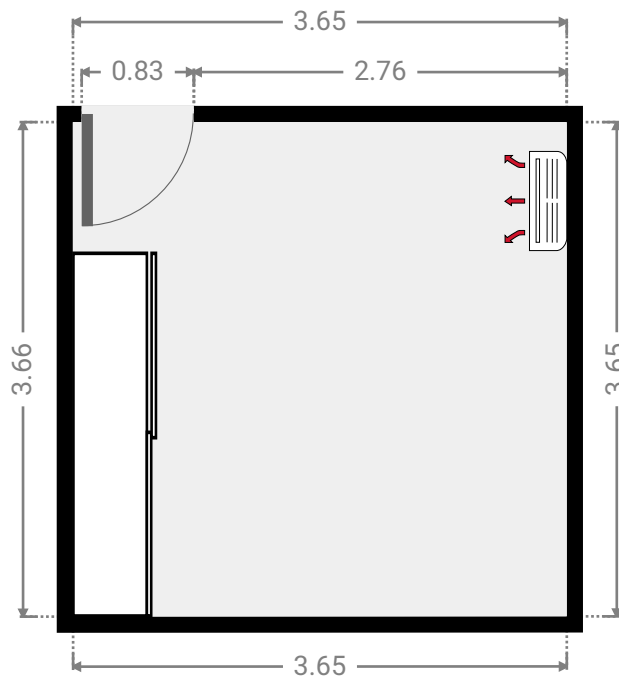
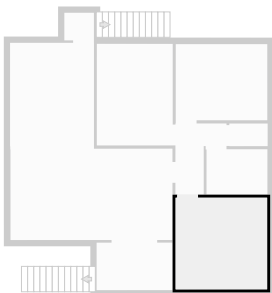

▼ .
1st Floor

WIDTH: 3.03 m • LENGTH: 1.90 m
AREA: 5.74 m² • PERIMETER: 9.85 m

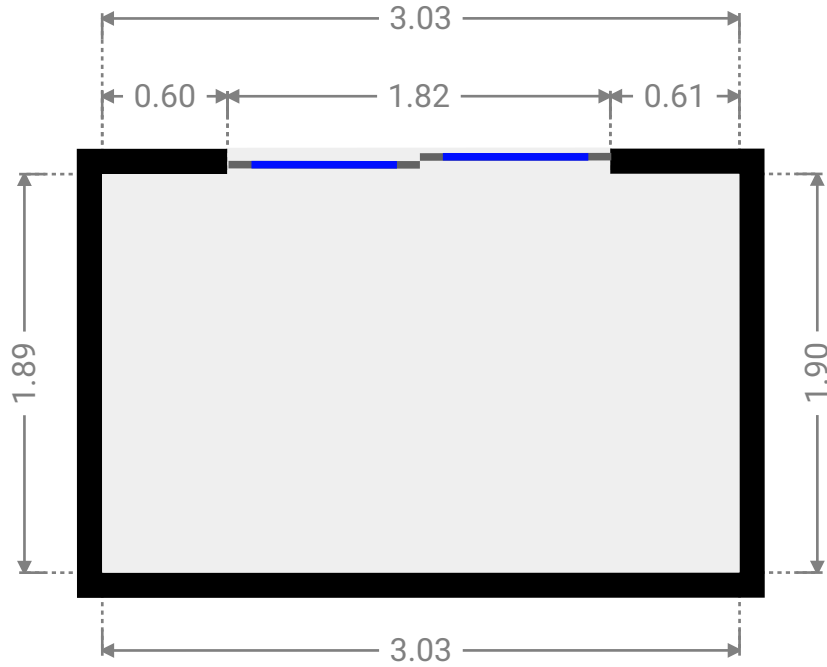
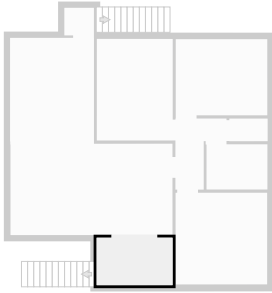

▼ .
1st Floor

WIDTH: 1.18 m • LENGTH: 1.10 m
AREA: 1.30 m² • PERIMETER: 4.56 m

