

188 Elphinstone Street

SUBMITTED BY
Janelle Casey

CREATED ON
2018-05-24

Floors
2

▼ Ground Floor

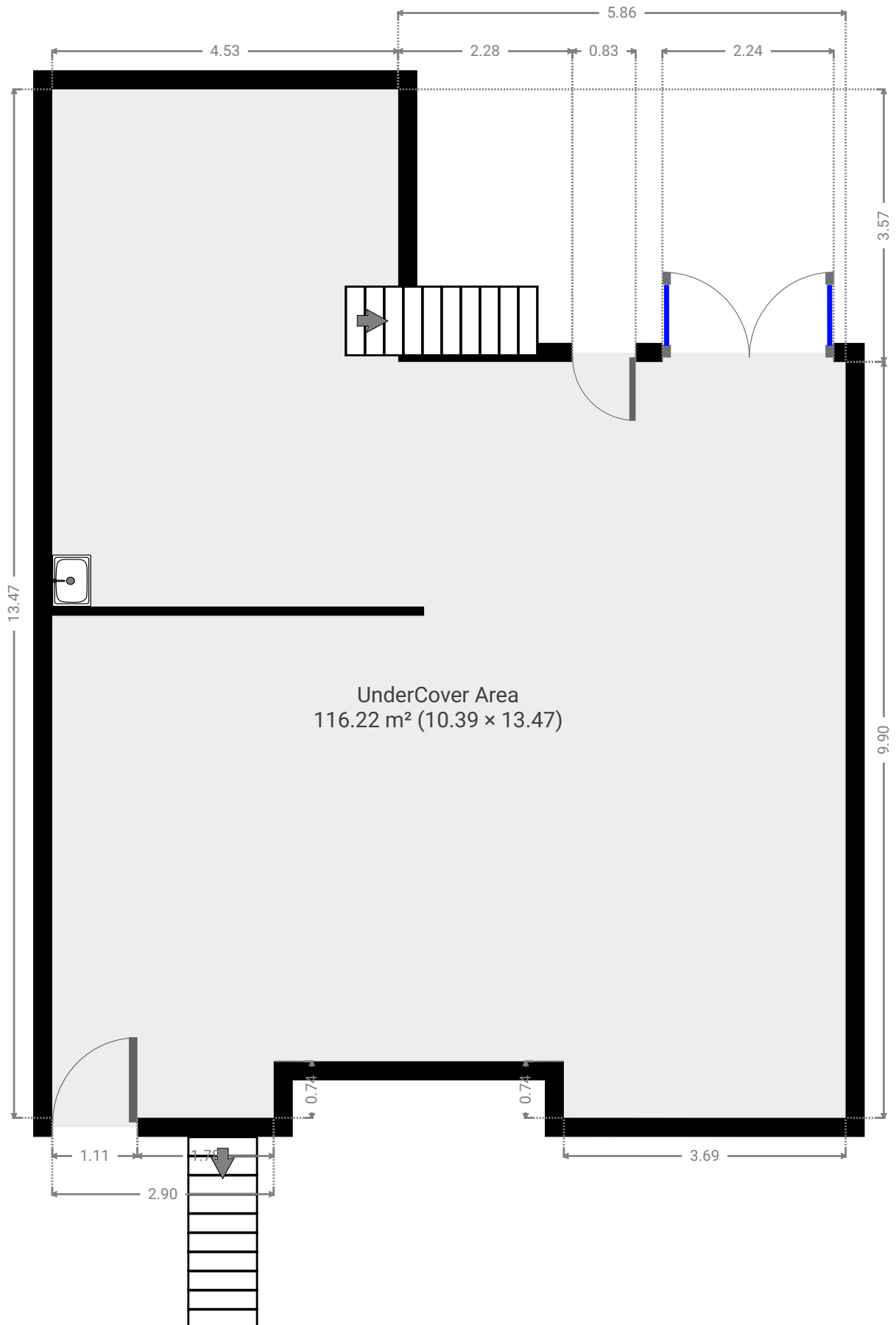

▼ UnderCover Area
Ground Floor

WIDTH: 10.39 m • LENGTH: 13.47 m
AREA: 116.22 m² • PERIMETER: 49.20 m

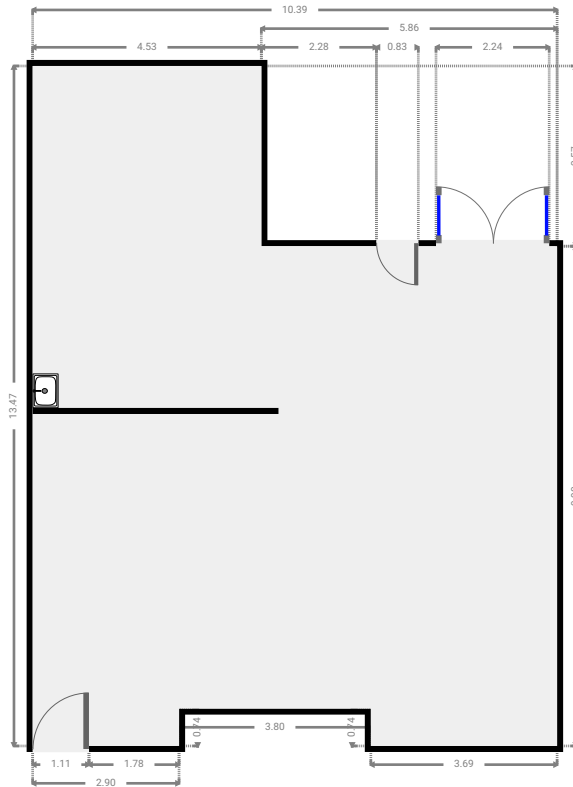
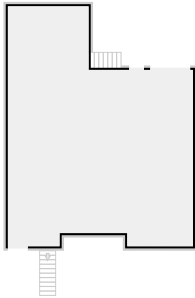

▼ 1st Floor

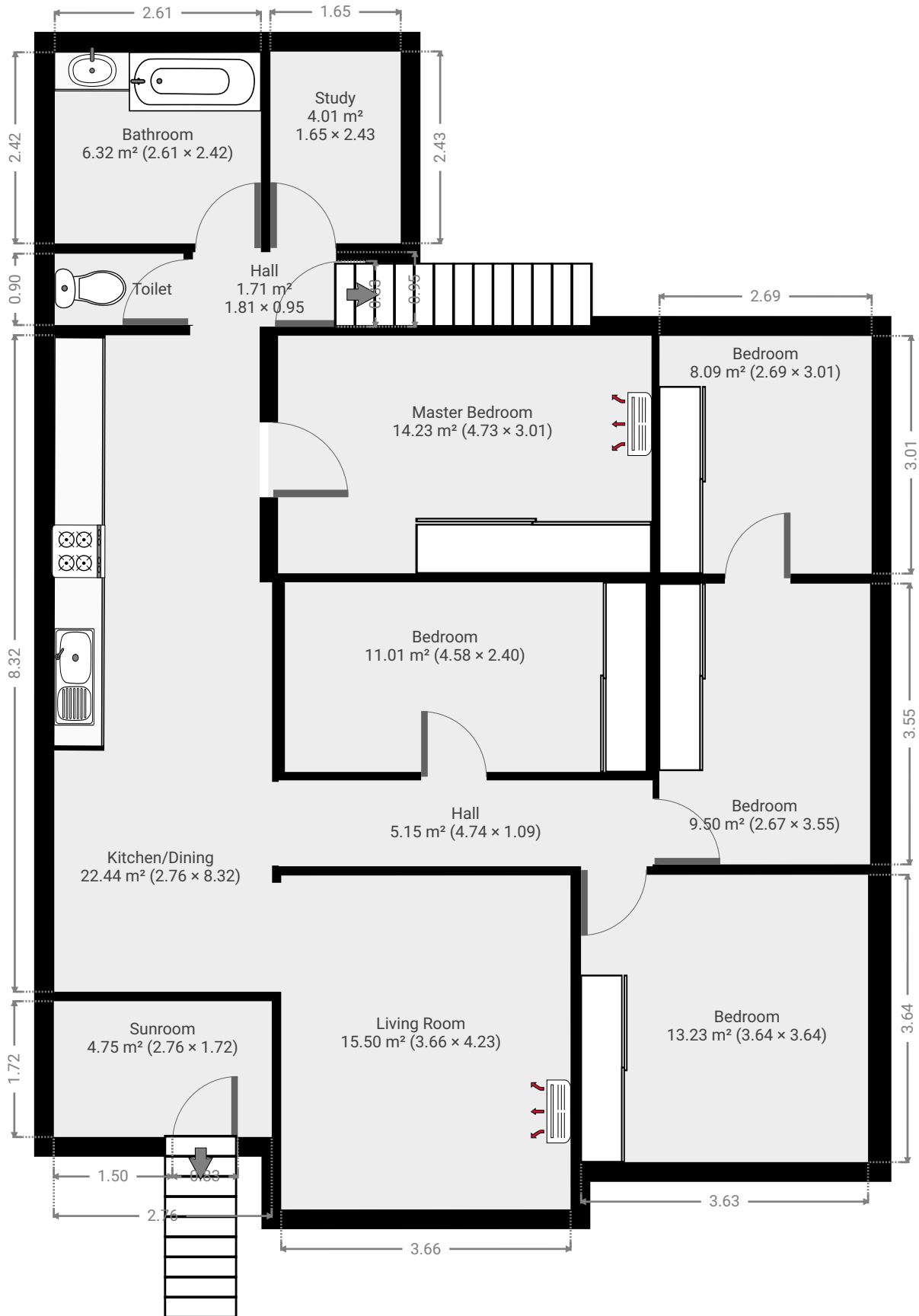

▼ **Kitchen/Dining**
1st Floor

WIDTH: 2.76 m • LENGTH: 8.32 m
AREA: 22.44 m² • PERIMETER: 22.15 m

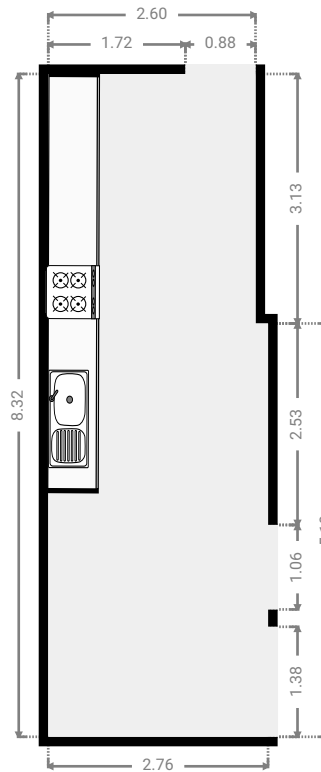

▼ **Living Room**
1st Floor

WIDTH: 3.66 m • LENGTH: 4.23 m
AREA: 15.50 m² • PERIMETER: 15.79 m

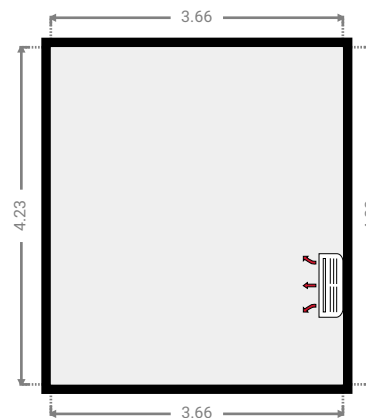
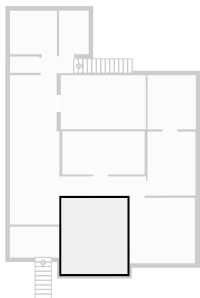

▼ **Sunroom**
1st Floor

WIDTH: 2.76 m • LENGTH: 1.72 m
AREA: 4.75 m² • PERIMETER: 8.96 m

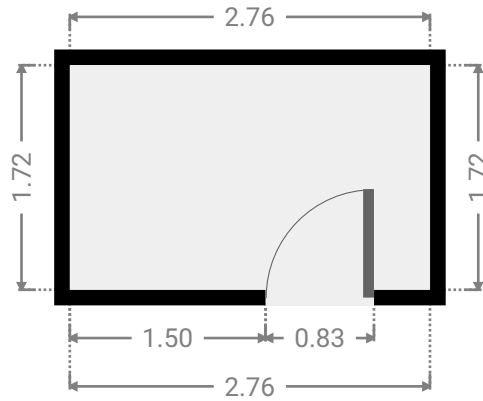
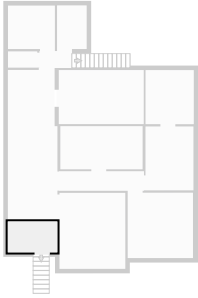

▼ **Hall**
1st Floor

WIDTH: 4.74 m • LENGTH: 1.09 m
AREA: 5.15 m² • PERIMETER: 11.65 m

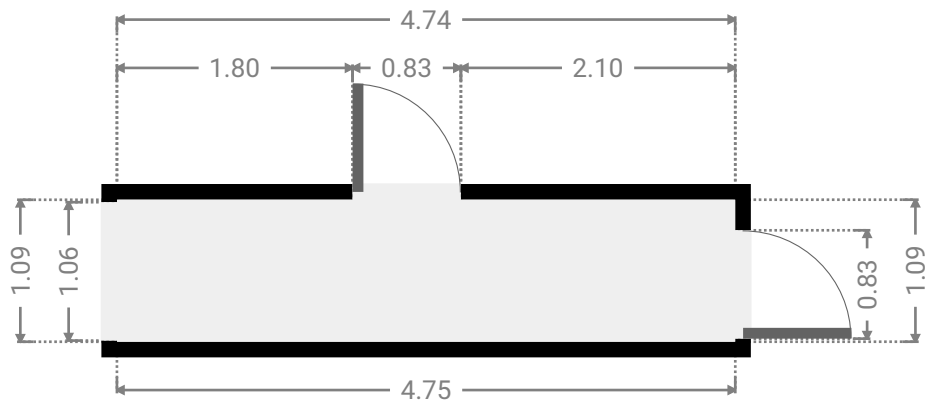
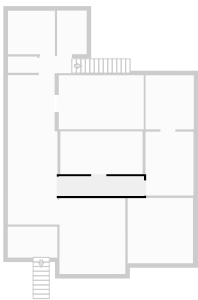

▼ **Bedroom**
1st Floor

WIDTH: 4.58 m • LENGTH: 2.40 m
AREA: 11.01 m² • PERIMETER: 13.97 m

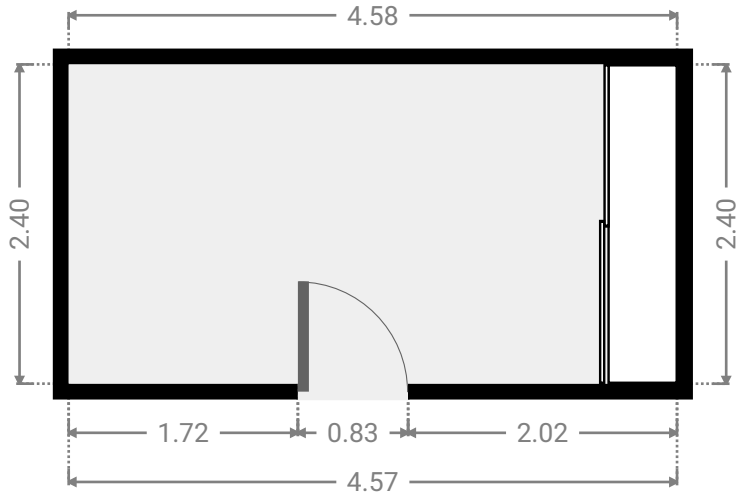
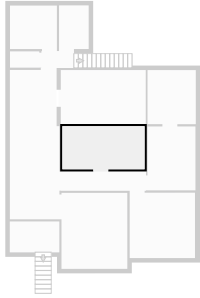

▼ **Bedroom**
1st Floor

WIDTH: 2.67 m • LENGTH: 3.55 m
AREA: 9.50 m² • PERIMETER: 12.45 m

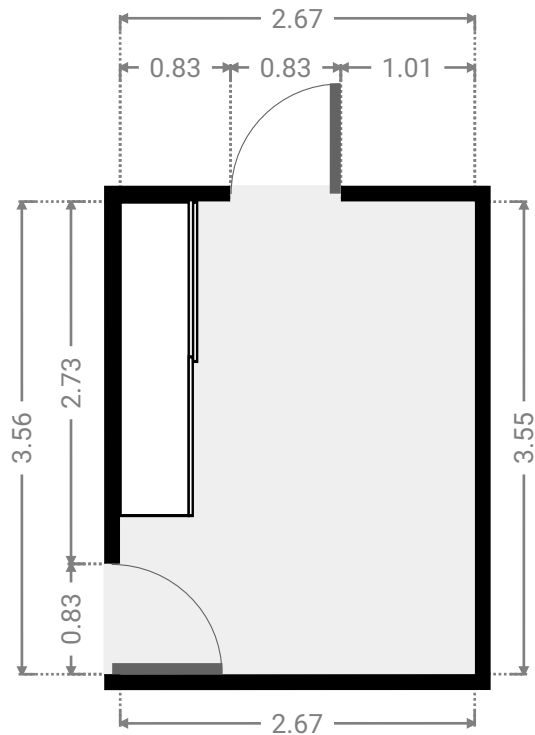
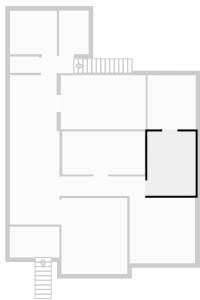

▼ **Bedroom**
1st Floor

WIDTH: 2.69 m • LENGTH: 3.01 m
AREA: 8.09 m² • PERIMETER: 11.39 m

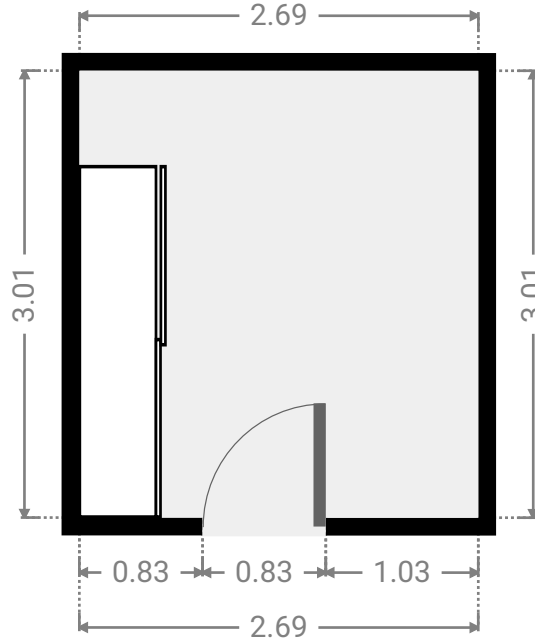
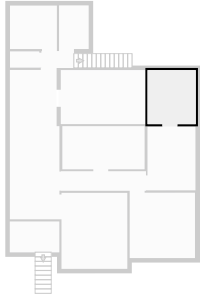

▼ **Bedroom**
1st Floor

WIDTH: 3.64 m • LENGTH: 3.64 m
AREA: 13.23 m² • PERIMETER: 14.55 m

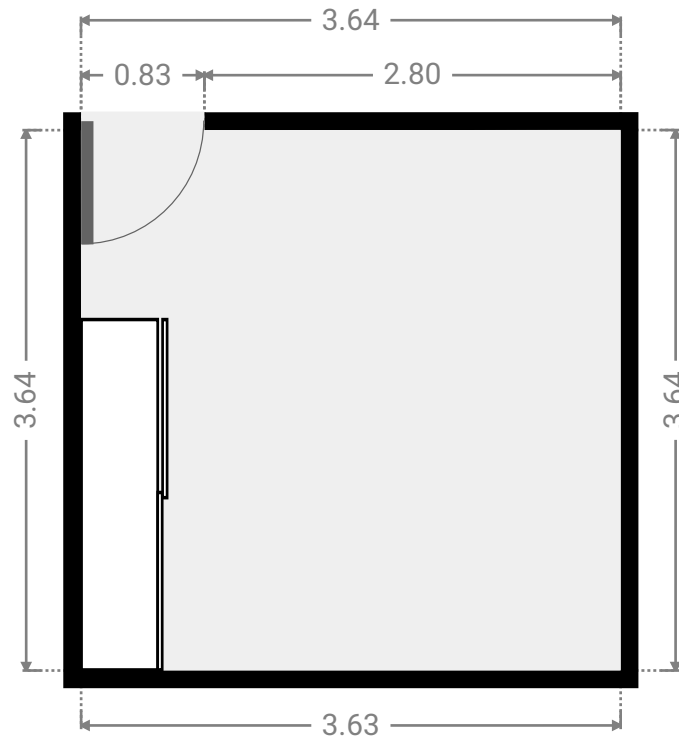
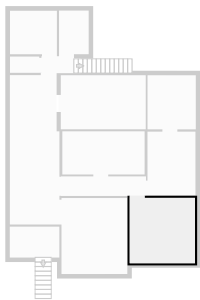

▼ Master Bedroom
1st Floor

WIDTH: 4.73 m • LENGTH: 3.01 m
AREA: 14.23 m² • PERIMETER: 15.48 m

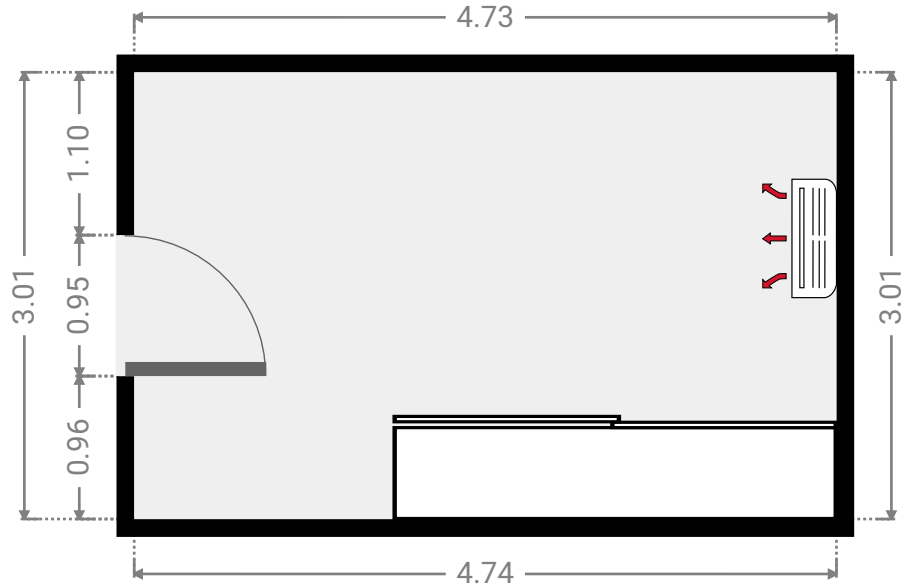
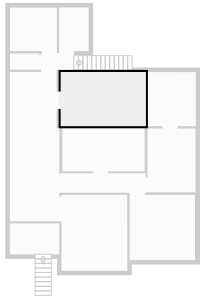

▼ Hall
1st Floor

WIDTH: 1.81 m • LENGTH: 0.95 m
AREA: 1.71 m² • PERIMETER: 5.51 m

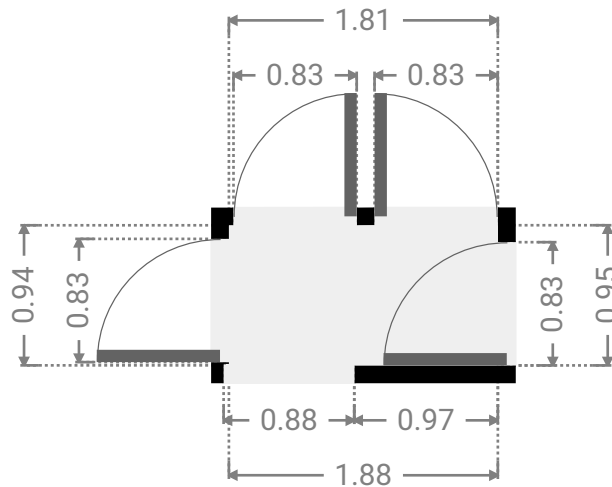
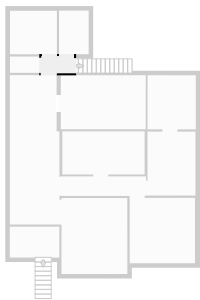

▼ **Toilet**
1st Floor

WIDTH: 1.63 m • LENGTH: 0.90 m
AREA: 1.47 m² • PERIMETER: 5.07 m

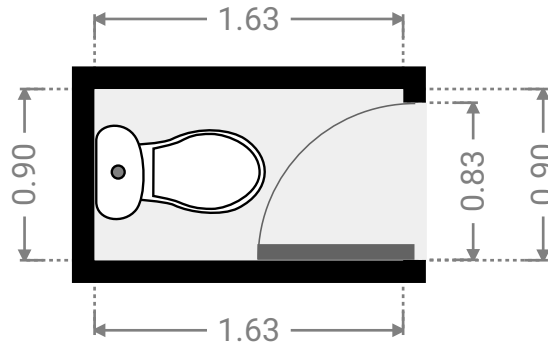
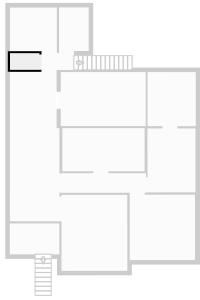

▼ **Bathroom**
1st Floor

WIDTH: 2.61 m • LENGTH: 2.42 m
AREA: 6.32 m² • PERIMETER: 10.06 m

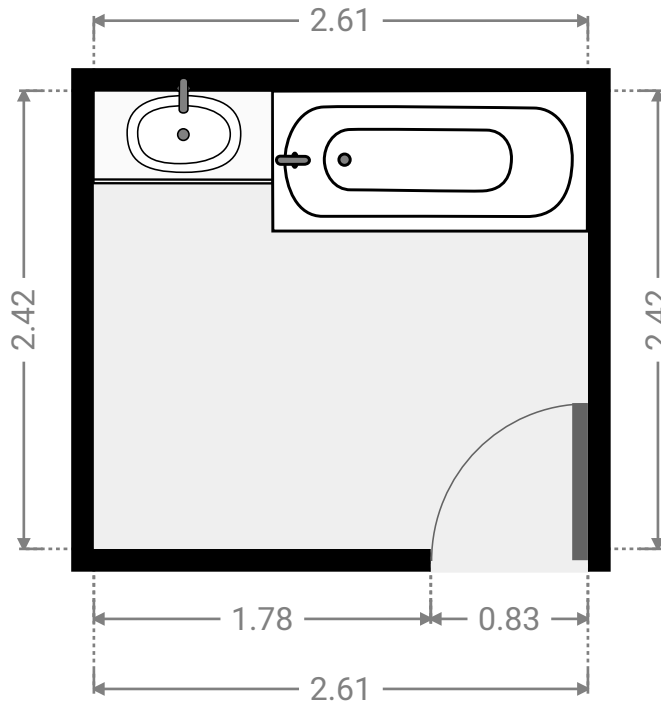
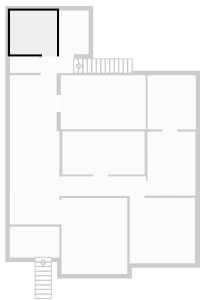

▼ **Study**
1st Floor

WIDTH: 1.65 m • LENGTH: 2.43 m
AREA: 4.01 m² • PERIMETER: 8.16 m

