

185 Rush Street

Created on
2021-03-11

Floors
2

▼ Ground Floor

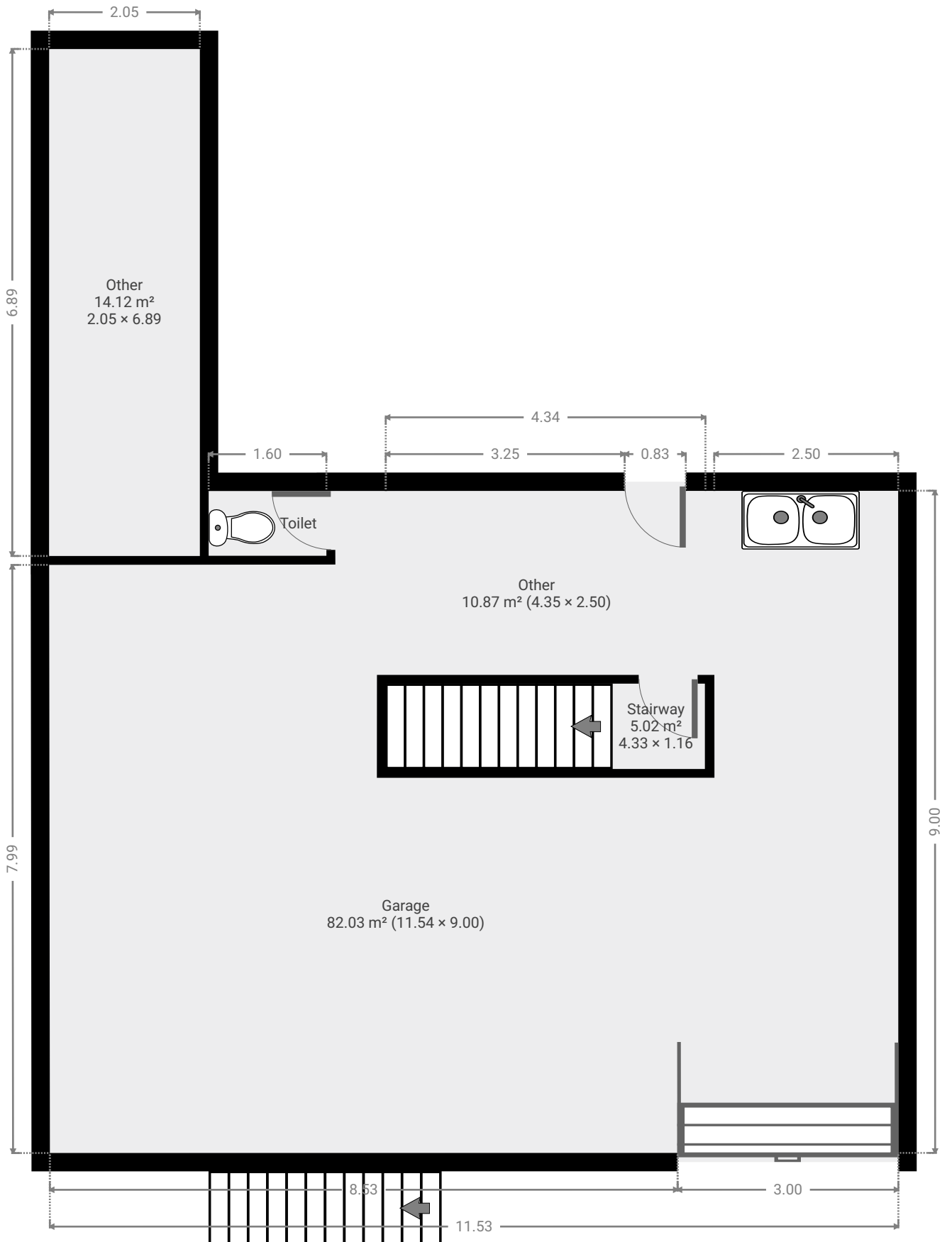

▼ **Garage**
Ground Floor

WIDTH: 11.54 m • LENGTH: 9.00 m
AREA: 82.03 m² • PERIMETER: 48.87 m

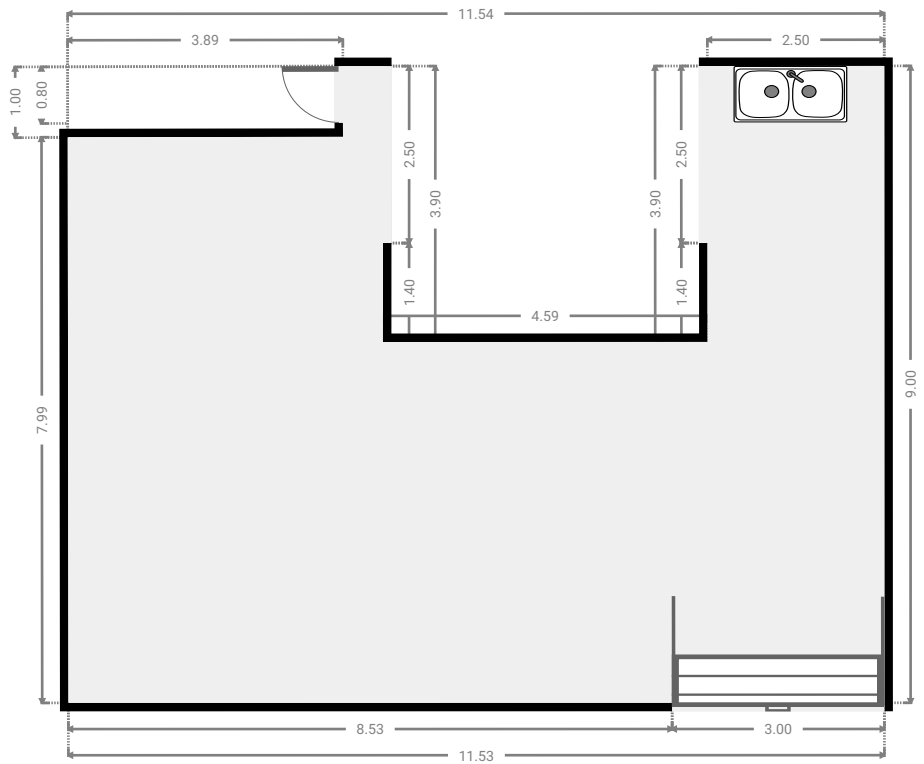
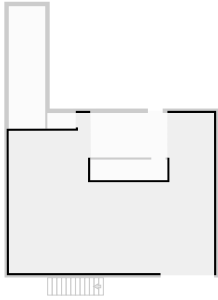

▼ **Stairway**
Ground Floor

WIDTH: 4.33 m • LENGTH: 1.16 m
AREA: 5.02 m² • PERIMETER: 10.98 m

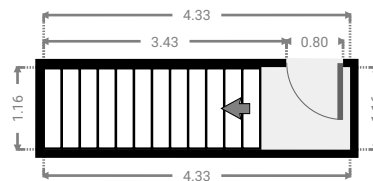
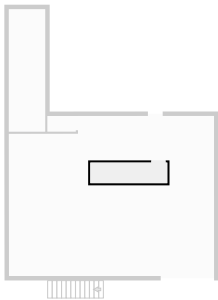

▼ Other
Ground Floor

WIDTH: 4.35 m • LENGTH: 2.50 m
AREA: 10.87 m² • PERIMETER: 13.69 m

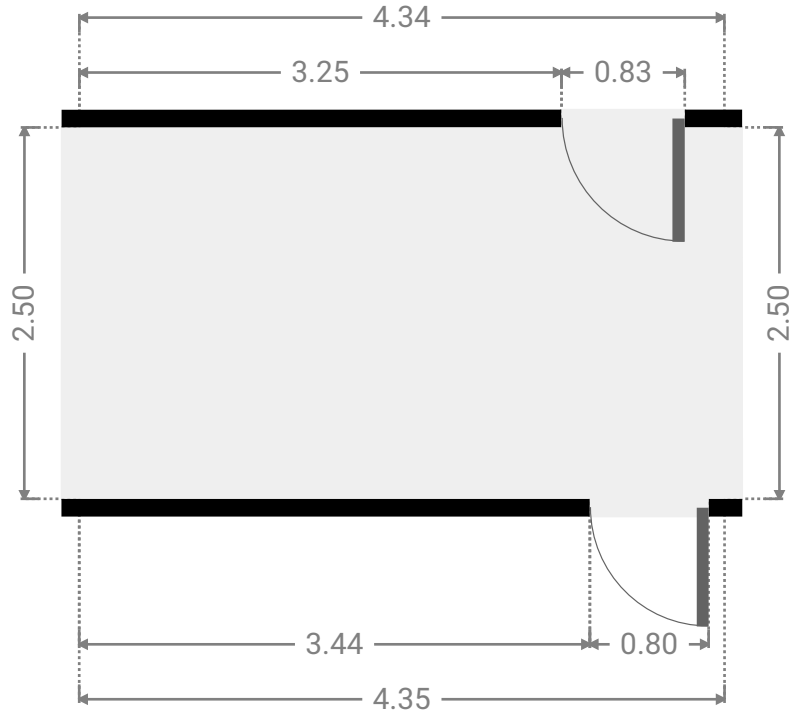
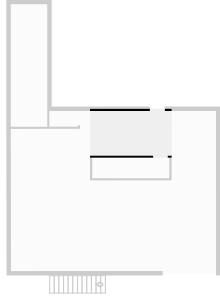

▼ Toilet
Ground Floor

WIDTH: 1.60 m • LENGTH: 0.88 m
AREA: 1.41 m² • PERIMETER: 4.96 m

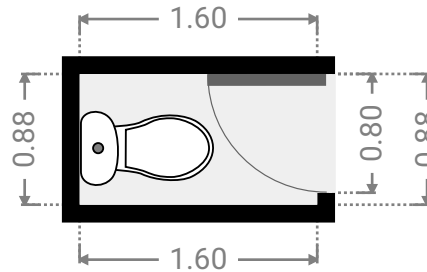
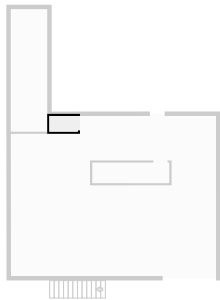

▼ Other
Ground Floor

WIDTH: 2.05 m • LENGTH: 6.89 m
AREA: 14.12 m² • PERIMETER: 17.88 m

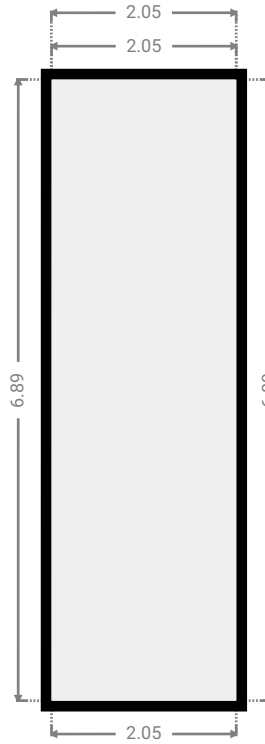
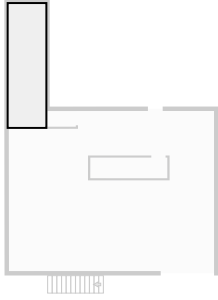

▼ 1st Floor



▼ **Living Room**
1st Floor

WIDTH: 7.10 m • LENGTH: 4.67 m
AREA: 30.52 m² • PERIMETER: 29.93 m

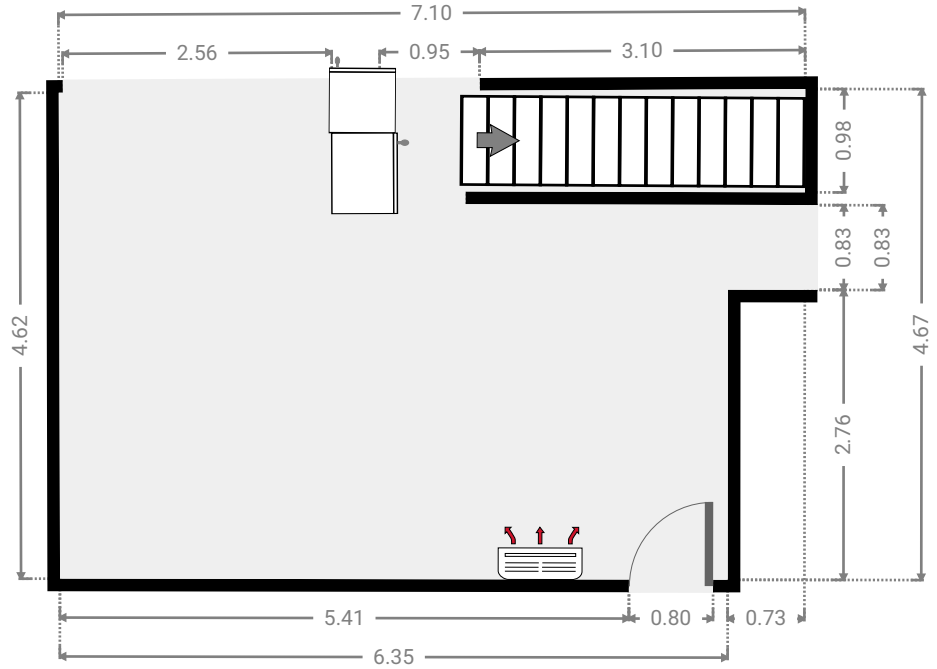
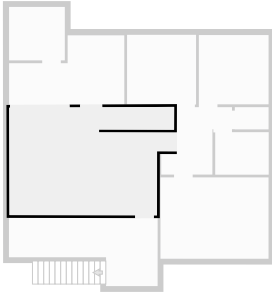

▼ **Hall**
1st Floor

WIDTH: 3.04 m • LENGTH: 2.90 m
AREA: 5.89 m² • PERIMETER: 11.89 m

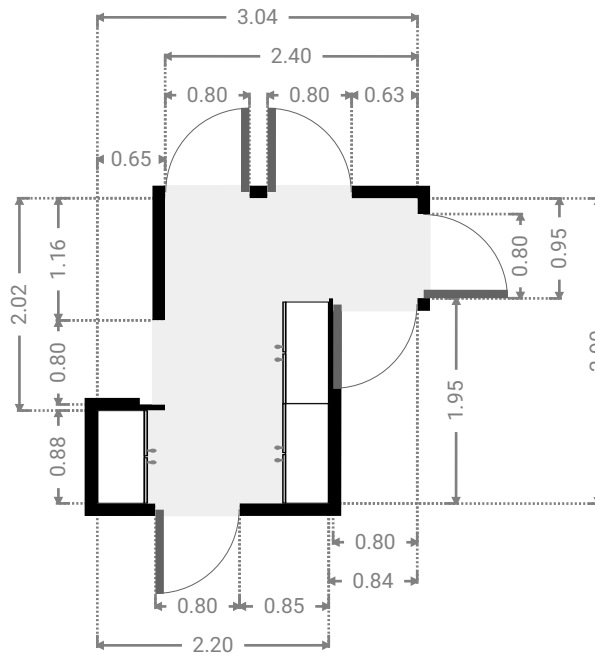
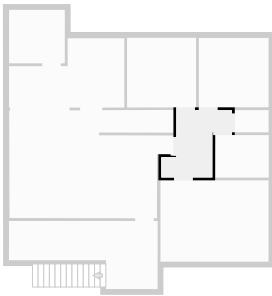

▼ Dining Room
1st Floor

WIDTH: 4.96 m • LENGTH: 2.98 m
AREA: 11.76 m² • PERIMETER: 15.88 m

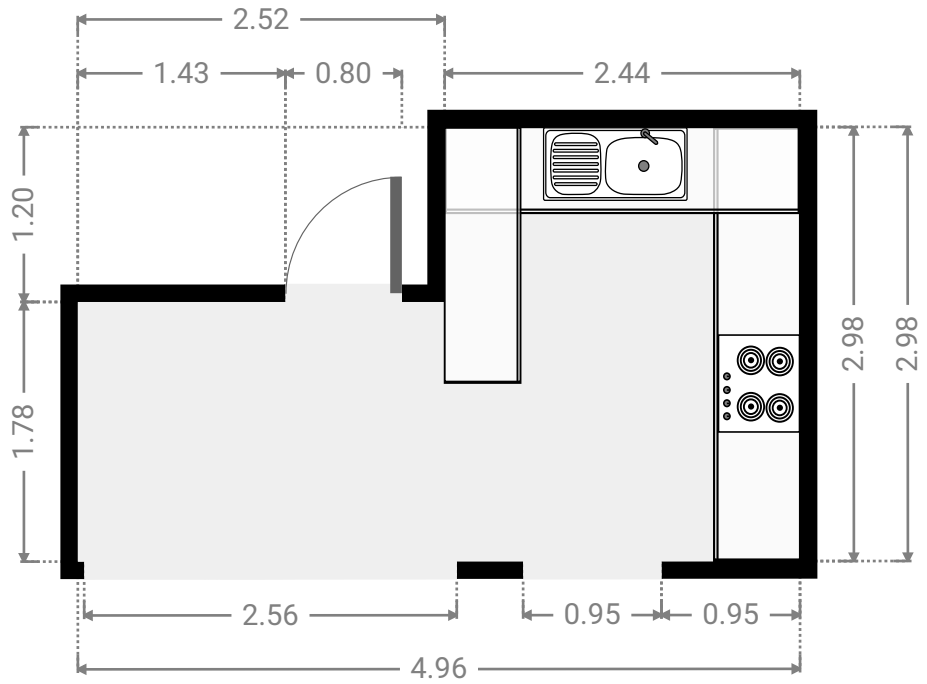
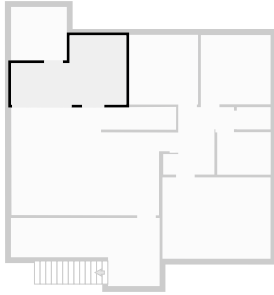

▼ Other
1st Floor

WIDTH: 2.40 m • LENGTH: 2.30 m
AREA: 5.52 m² • PERIMETER: 9.40 m

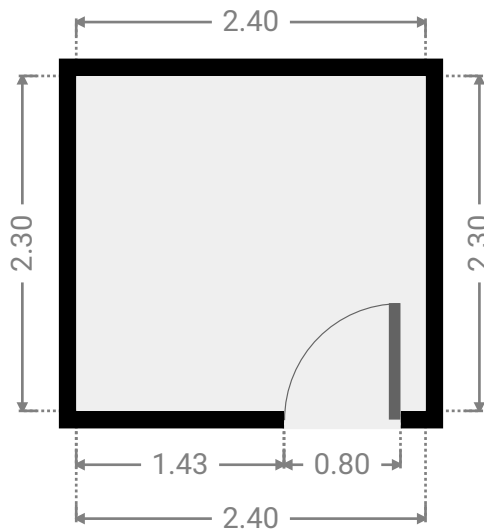
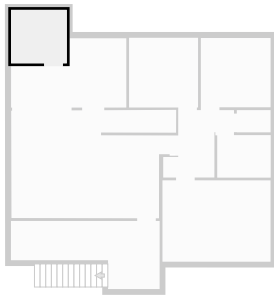

▼ **Bedroom**
1st Floor

WIDTH: 2.97 m • LENGTH: 3.00 m
AREA: 8.91 m² • PERIMETER: 11.94 m

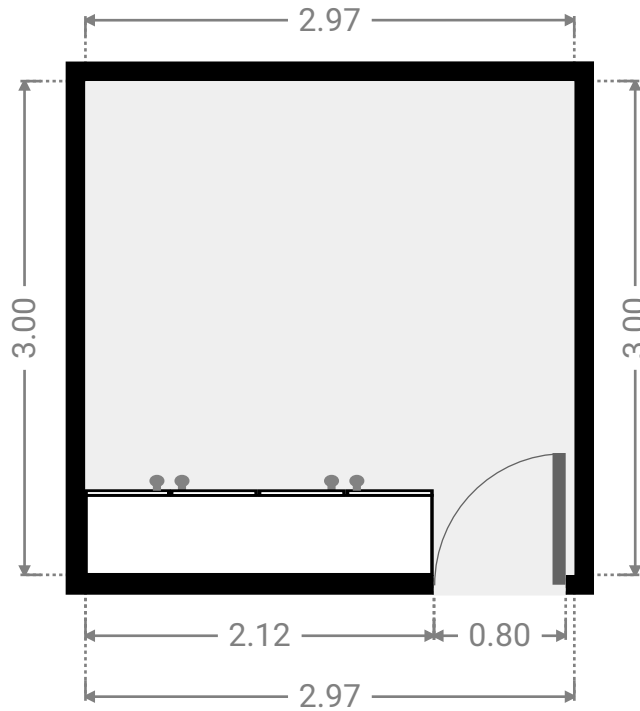
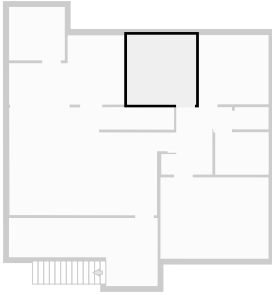

▼ **Bedroom**
1st Floor

WIDTH: 3.00 m • LENGTH: 2.98 m
AREA: 8.94 m² • PERIMETER: 11.96 m

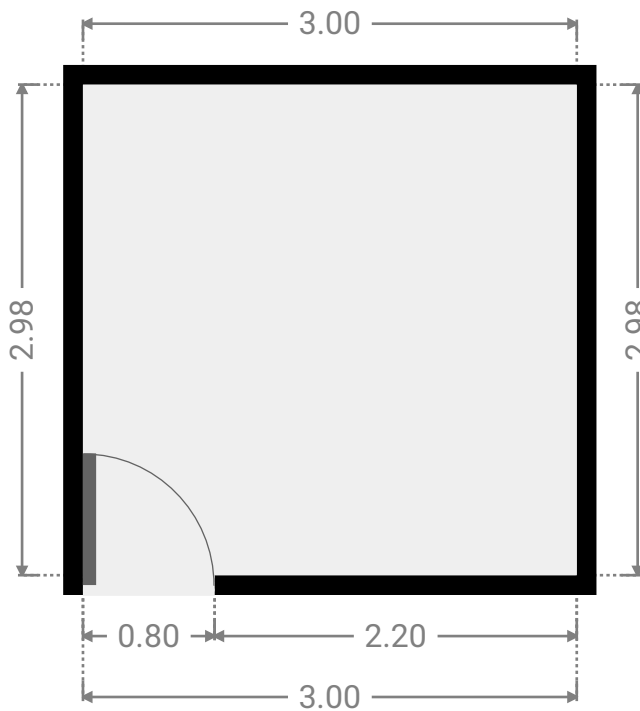
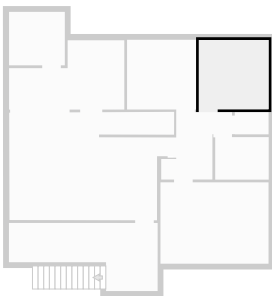

▼ Toilet
1st Floor

WIDTH: 1.45 m • LENGTH: 0.96 m
AREA: 1.39 m² • PERIMETER: 4.82 m

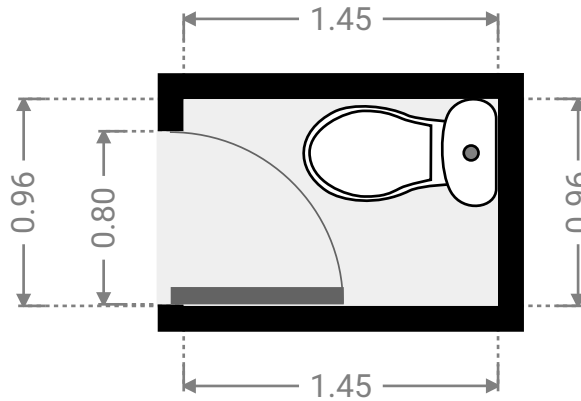
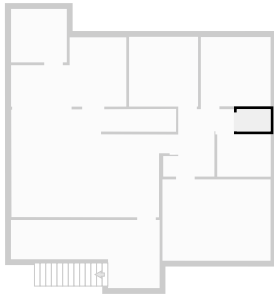

▼ Bathroom
1st Floor

WIDTH: 2.30 m • LENGTH: 1.83 m
AREA: 4.21 m² • PERIMETER: 8.26 m

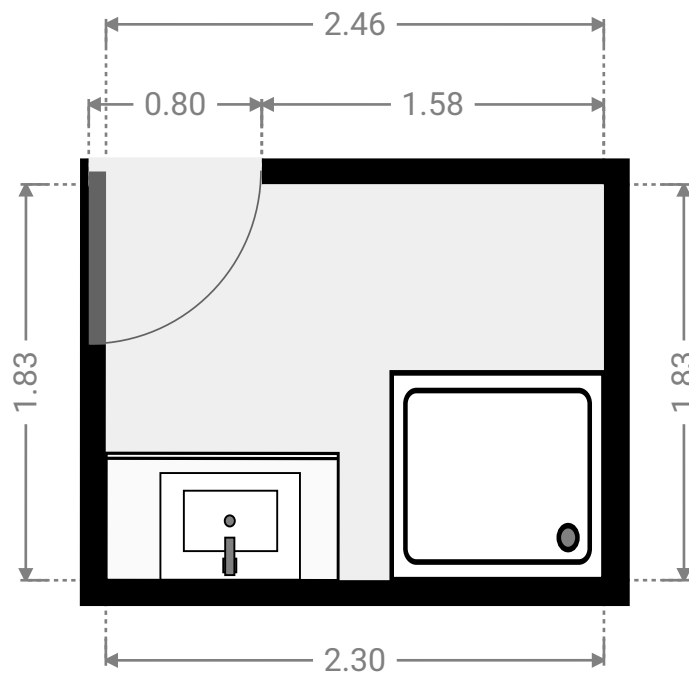
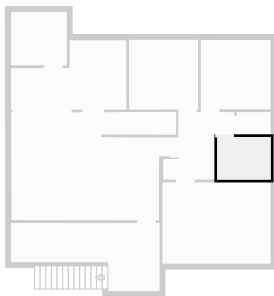

▼ Master Bedroom
1st Floor

WIDTH: 4.65 m • LENGTH: 3.50 m
AREA: 16.27 m² • PERIMETER: 16.30 m

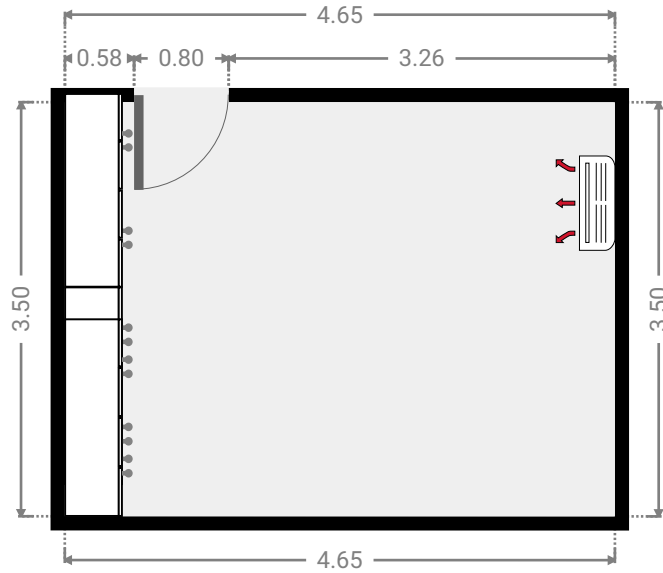
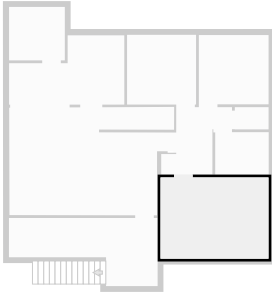

▼ Other
1st Floor

WIDTH: 6.40 m • LENGTH: 2.93 m
AREA: 13.57 m² • PERIMETER: 18.66 m

