

# 184 Grimley Street

**SUBMITTED BY**  
Ray White Rockhampton Casey  
stockers@cqoz.com

---

**CREATED ON**  
2022-02-14

---

**Floors**  
1

---

▼ Ground Floor



▼ **Living Room**  
Ground Floor

WIDTH: 4.40 m • LENGTH: 3.65 m  
AREA: 16.06 m<sup>2</sup> • PERIMETER: 16.10 m

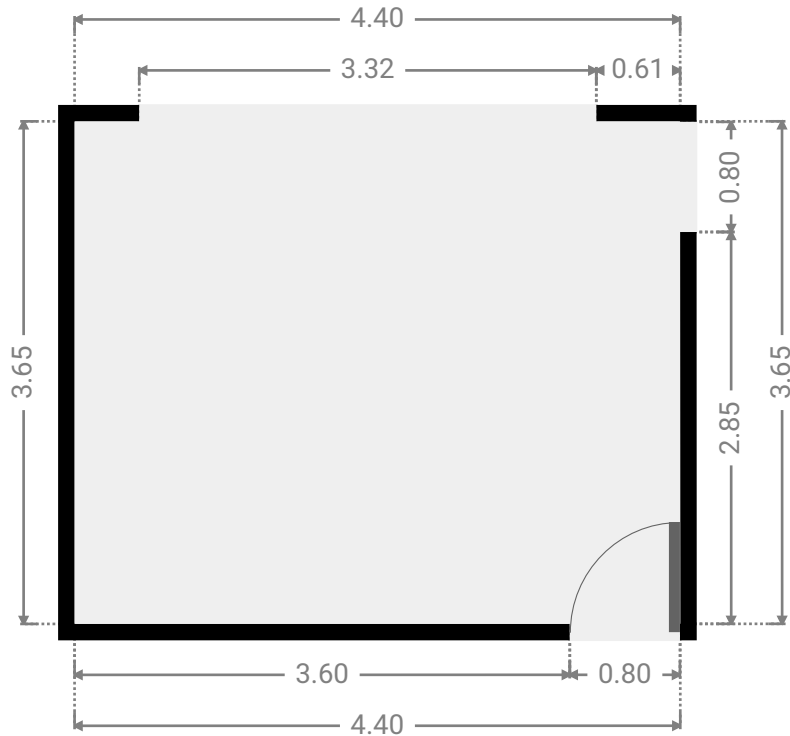
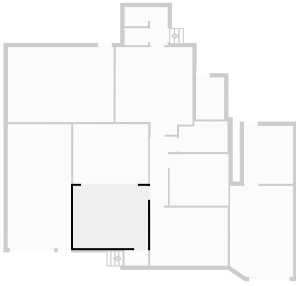

▼ **Dining Room**  
Ground Floor

WIDTH: 4.40 m • LENGTH: 3.50 m  
AREA: 15.40 m<sup>2</sup> • PERIMETER: 15.80 m

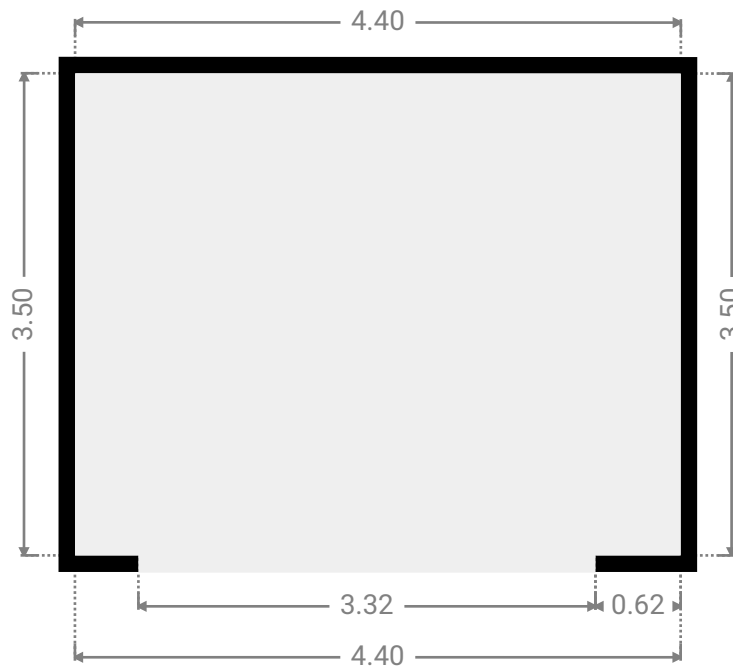
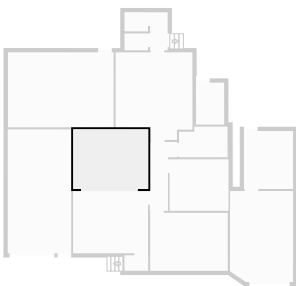

▼ Hall  
Ground Floor

WIDTH: 1.60 m • LENGTH: 4.04 m  
AREA: 4.80 m<sup>2</sup> • PERIMETER: 11.28 m

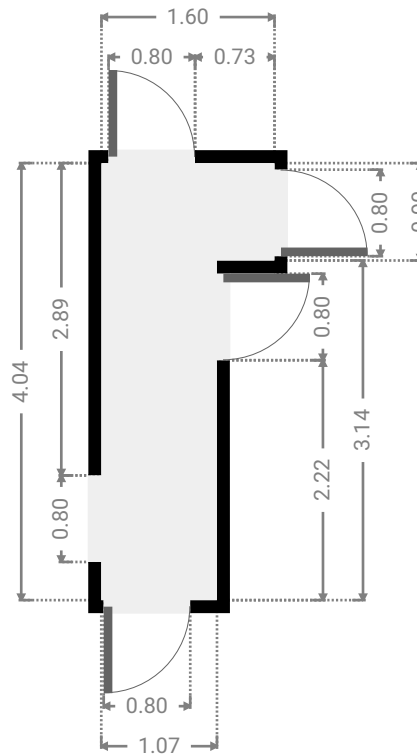

▼ Bedroom  
Ground Floor

WIDTH: 4.55 m • LENGTH: 3.40 m  
AREA: 15.47 m<sup>2</sup> • PERIMETER: 15.90 m

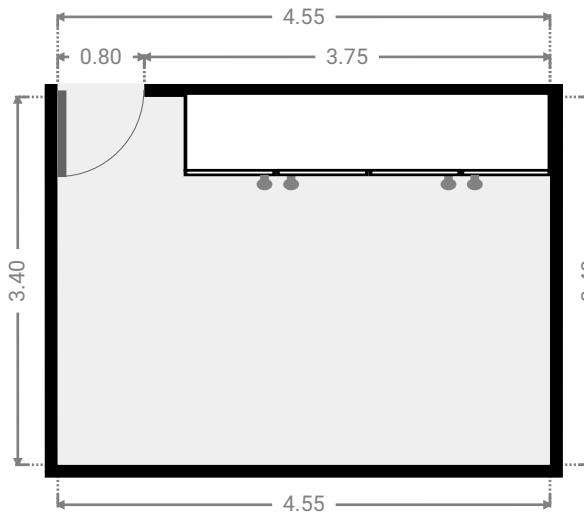

▼ **Bedroom**  
Ground Floor

WIDTH: 3.46 m • LENGTH: 3.02 m  
AREA: 10.44 m<sup>2</sup> • PERIMETER: 12.96 m

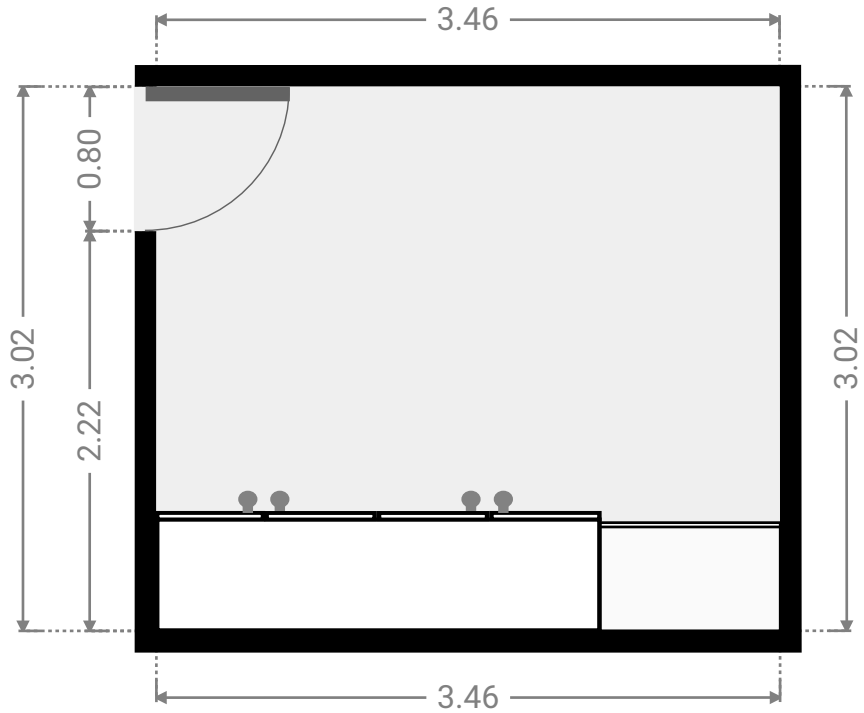
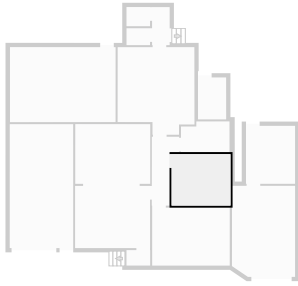

▼ **Bathroom**  
Ground Floor

WIDTH: 2.85 m • LENGTH: 1.80 m  
AREA: 4.85 m<sup>2</sup> • PERIMETER: 9.29 m

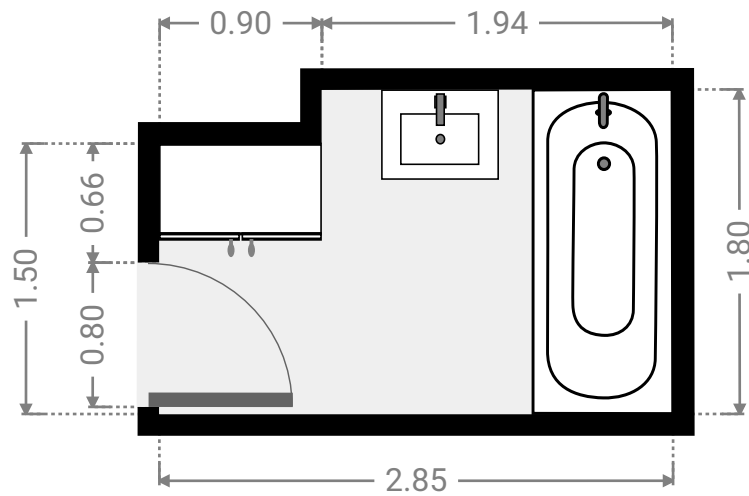
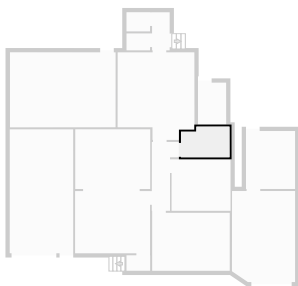

▼ **Kitchen**  
Ground Floor

WIDTH: 4.51 m • LENGTH: 5.14 m  
AREA: 21.08 m<sup>2</sup> • PERIMETER: 19.28 m

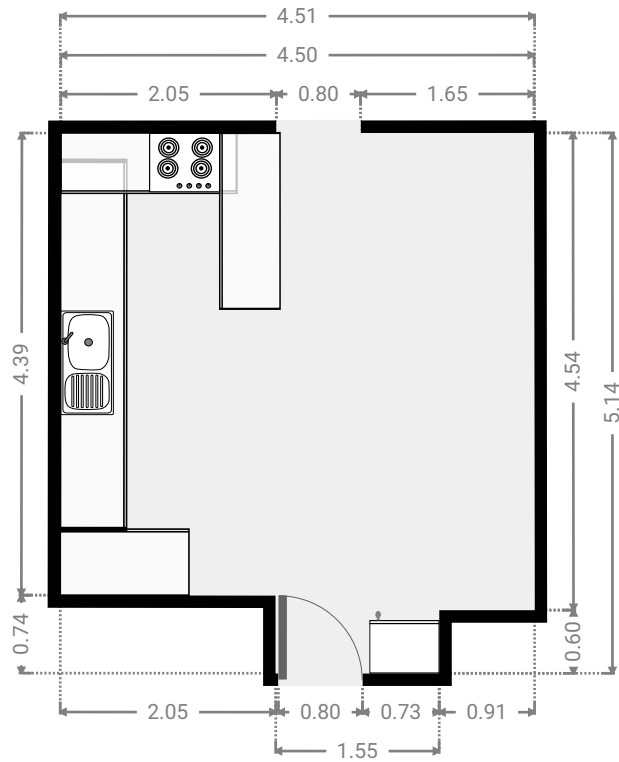
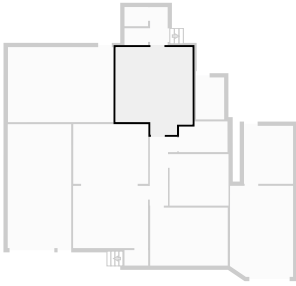

▼ **Hall**  
Ground Floor

WIDTH: 1.03 m • LENGTH: 2.23 m  
AREA: 2.30 m<sup>2</sup> • PERIMETER: 6.52 m

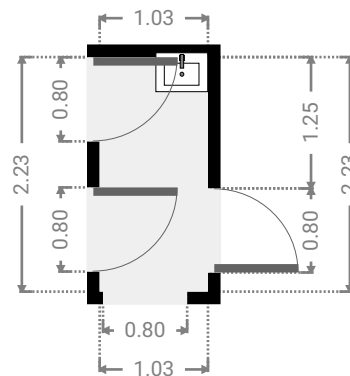

▼ **Closet**  
Ground Floor

WIDTH: 1.38 m • LENGTH: 0.99 m  
AREA: 1.37 m<sup>2</sup> • PERIMETER: 4.74 m

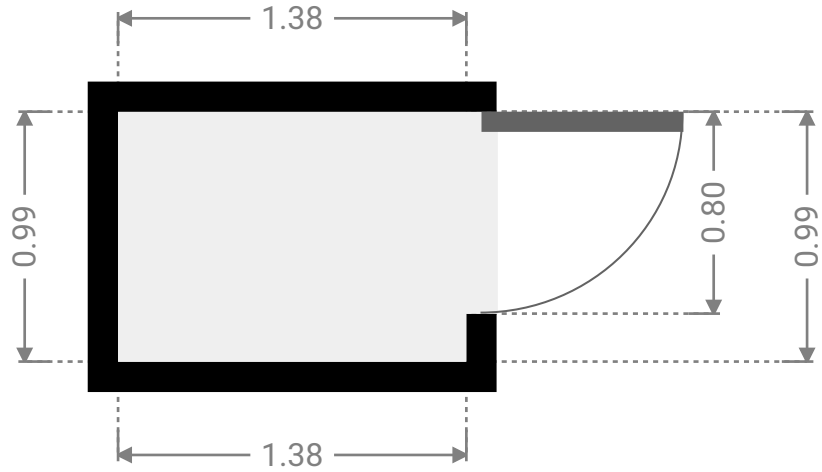
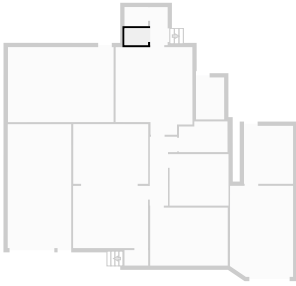

▼ **Toilet**  
Ground Floor

WIDTH: 1.38 m • LENGTH: 1.12 m  
AREA: 1.55 m<sup>2</sup> • PERIMETER: 5.01 m

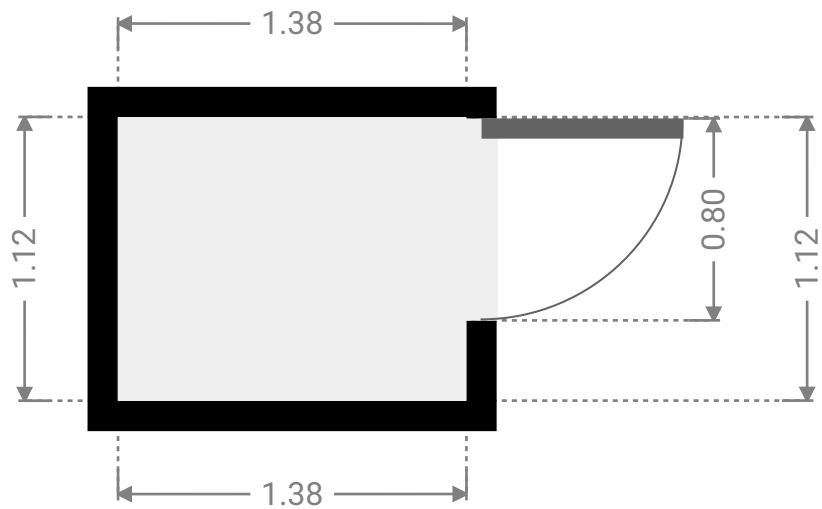

▼ **Laundry Room**  
Ground Floor

WIDTH: 1.65 m • LENGTH: 2.46 m  
AREA: 4.06 m<sup>2</sup> • PERIMETER: 8.22 m

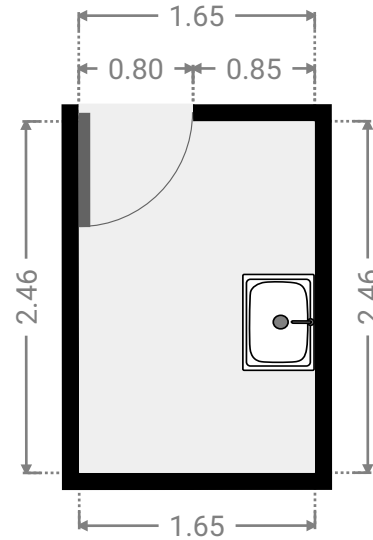
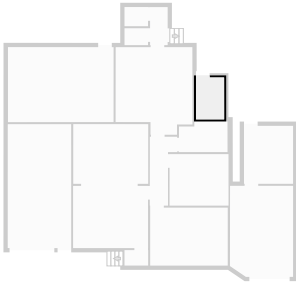

▼ **Living Room**  
Ground Floor

WIDTH: 2.88 m • LENGTH: 3.40 m  
AREA: 9.79 m<sup>2</sup> • PERIMETER: 12.56 m

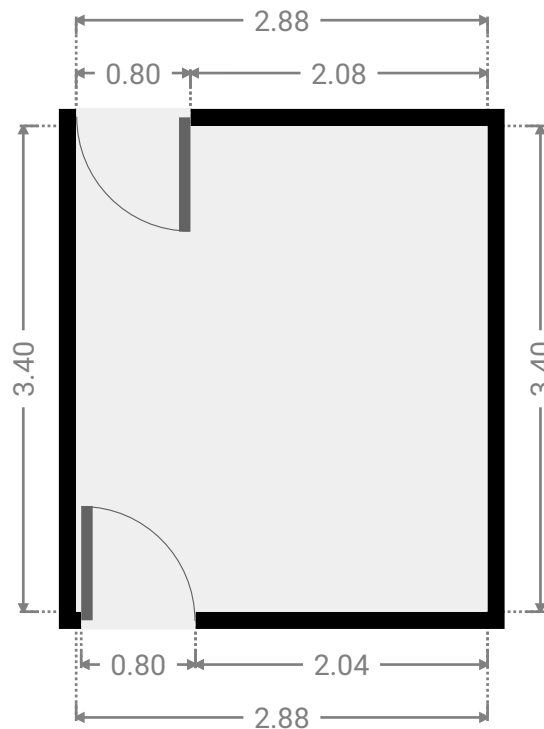
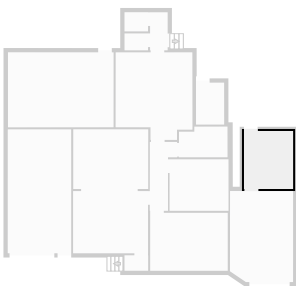



▼ Garage  
Ground Floor

WIDTH: 3.70 m • LENGTH: 5.34 m  
AREA: 19.48 m<sup>2</sup> • PERIMETER: 17.65 m

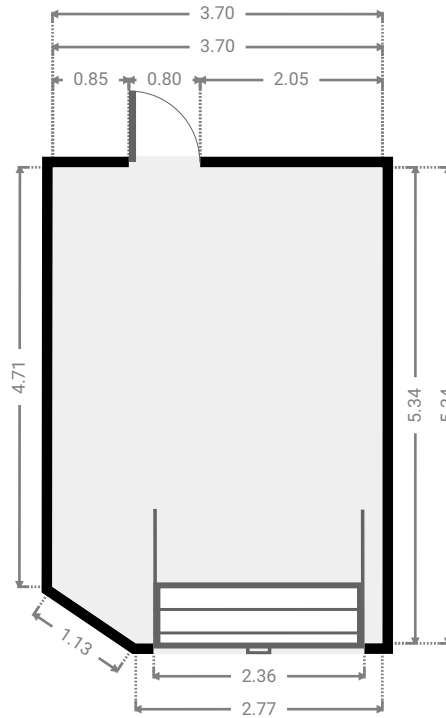
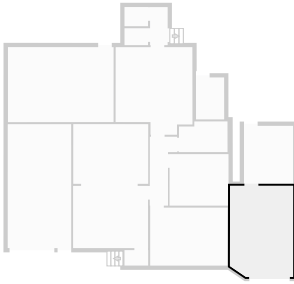

▼ Garage  
Ground Floor

WIDTH: 3.72 m • LENGTH: 7.27 m  
AREA: 27.06 m<sup>2</sup> • PERIMETER: 21.98 m

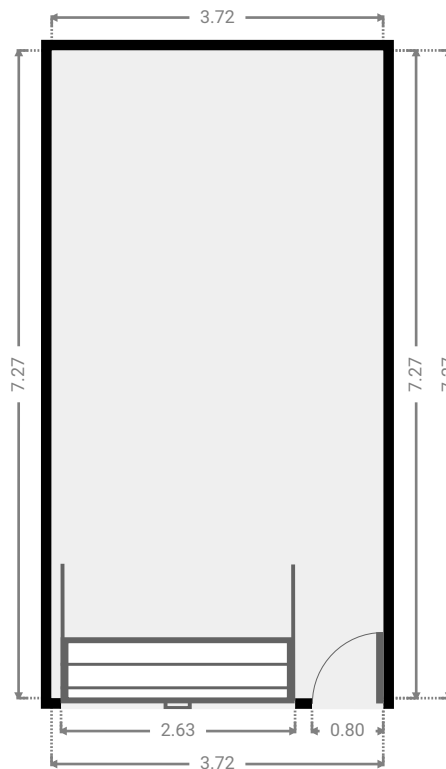

▼ Other  
Ground Floor

WIDTH: 6.20 m • LENGTH: 4.40 m  
AREA: 27.27 m<sup>2</sup> • PERIMETER: 21.20 m

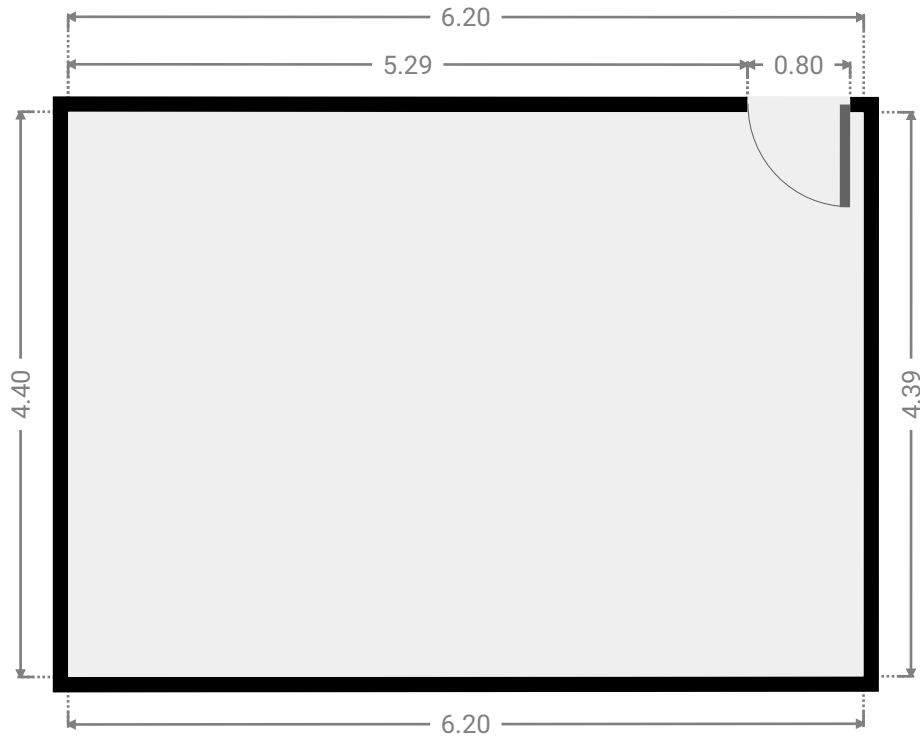
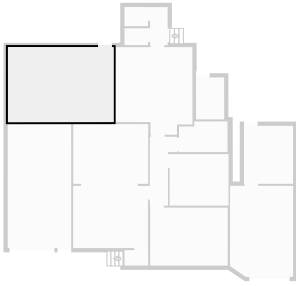

▼ Other  
Ground Floor

WIDTH: 1.39 m • LENGTH: 0.91 m  
AREA: 1.25 m<sup>2</sup> • PERIMETER: 4.58 m

