

18 Verney Street

SUBMITTED BY
Ray White Rockhampton Casey
stockers@cqoz.com

CREATED ON
2022-12-01

Floors
2

▼ Ground Floor

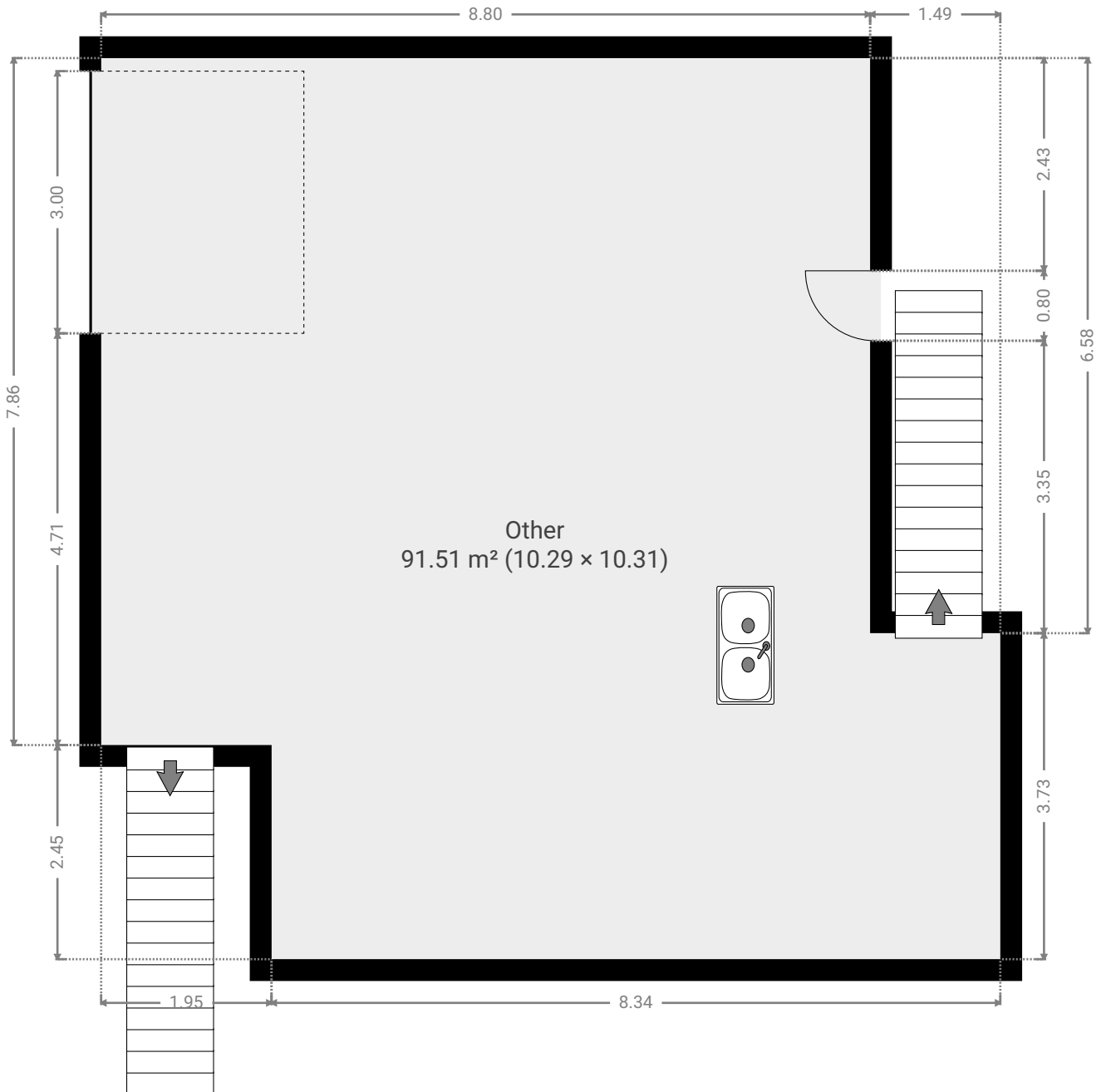

▼ Other Ground Floor

WIDTH: 10.31 m • LENGTH: 10.29 m
AREA: 91.51 m² • PERIMETER: 41.20 m

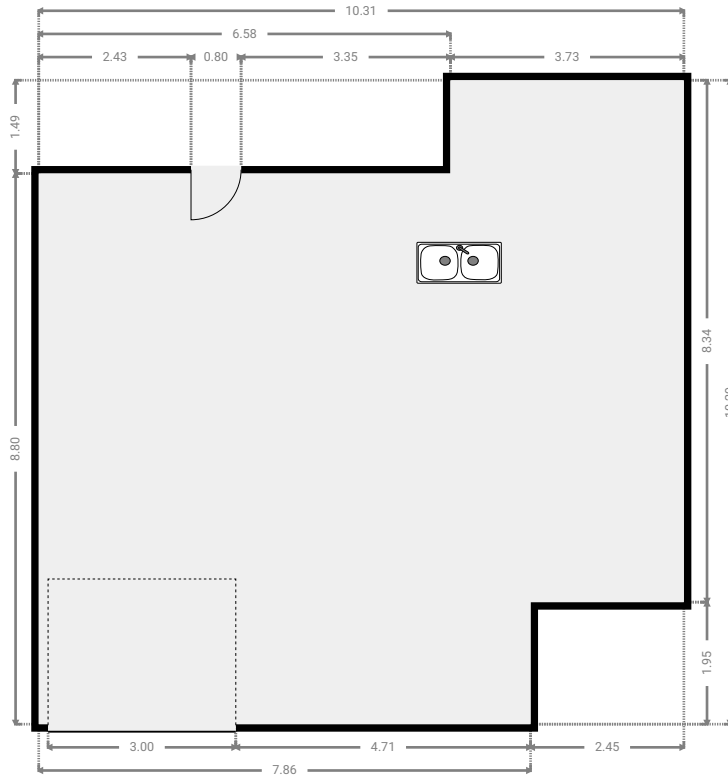
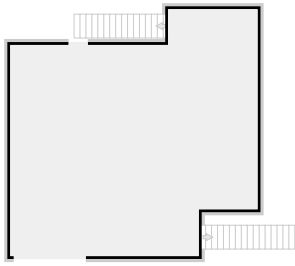

▼ 1st Floor

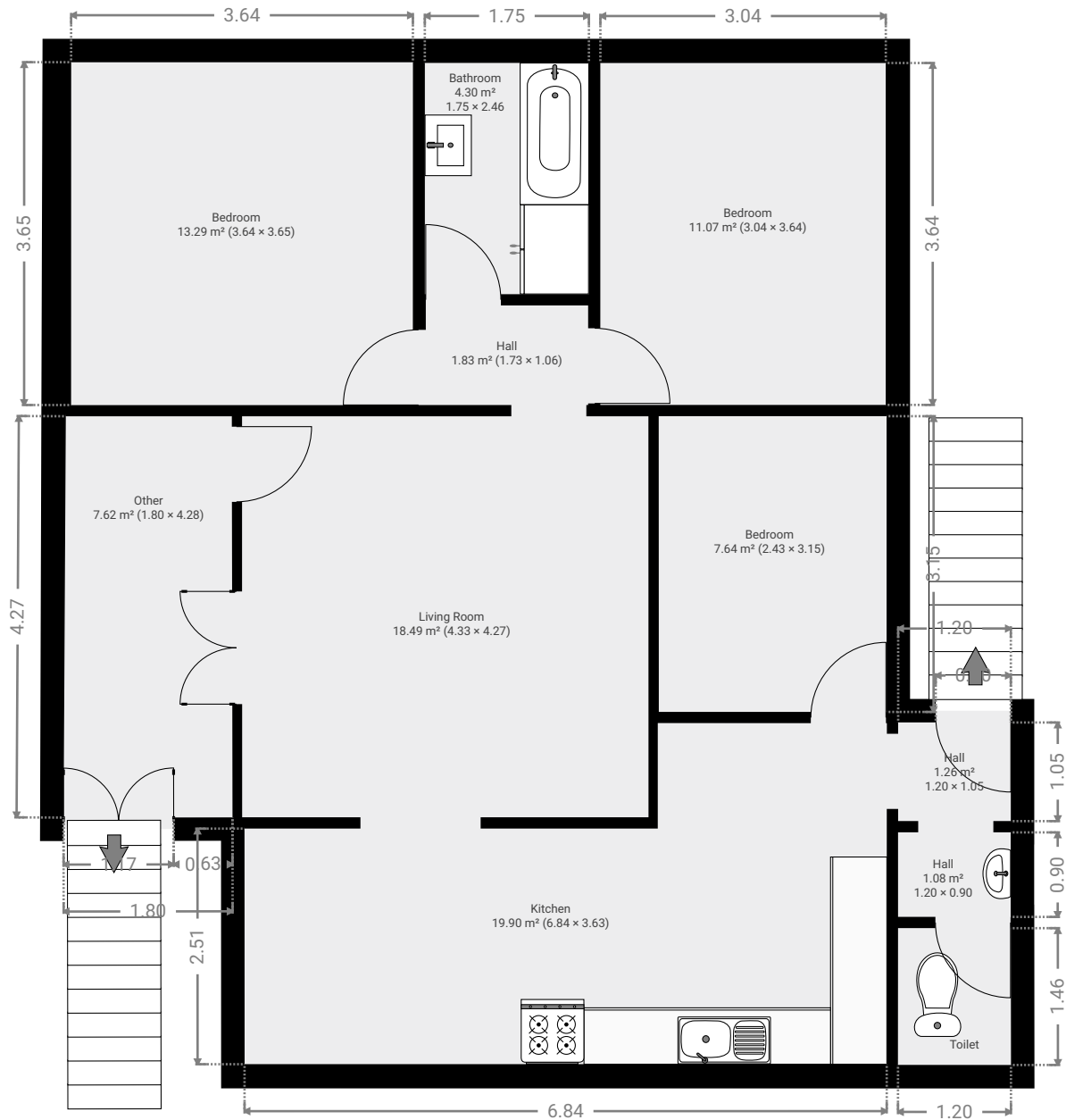

▼ **Bathroom**
1st Floor

WIDTH: 2.46 m • LENGTH: 1.75 m
AREA: 4.30 m² • PERIMETER: 8.42 m

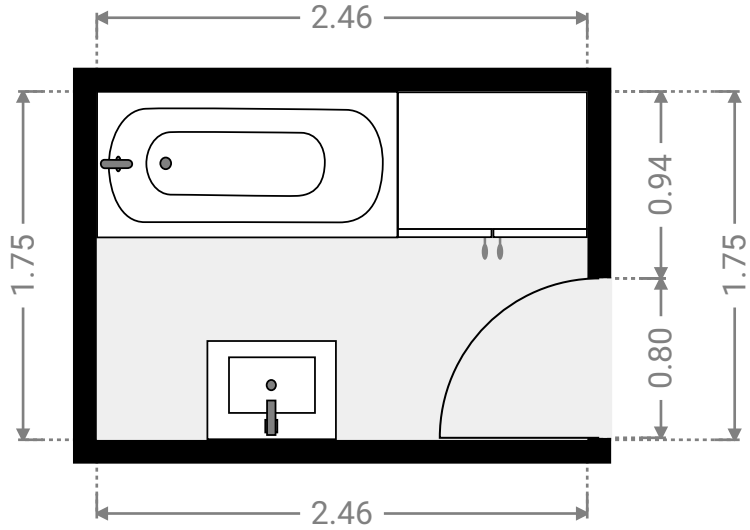
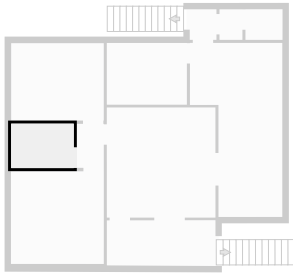

▼ **Bedroom**
1st Floor

WIDTH: 3.15 m • LENGTH: 2.43 m
AREA: 7.64 m² • PERIMETER: 11.15 m

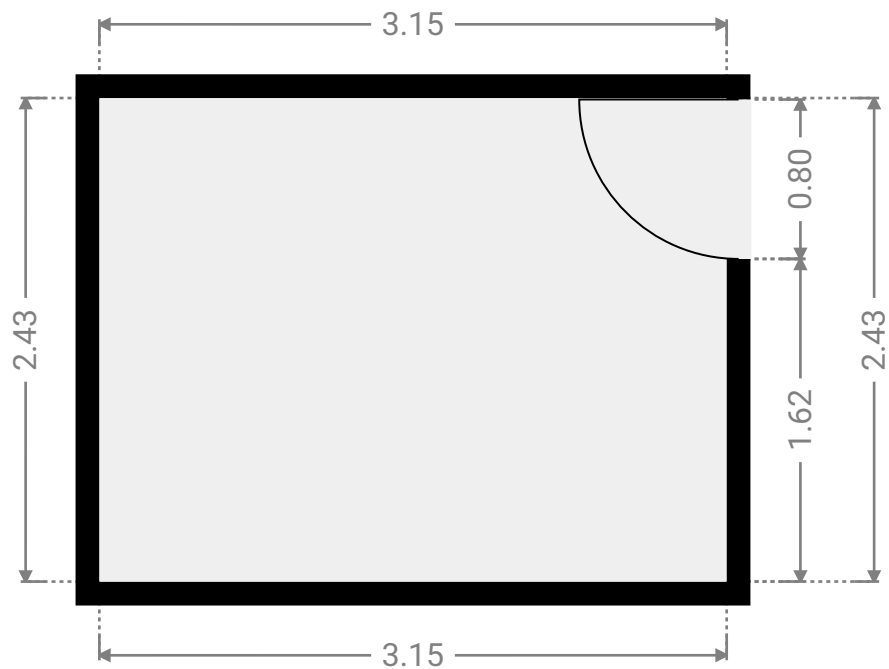
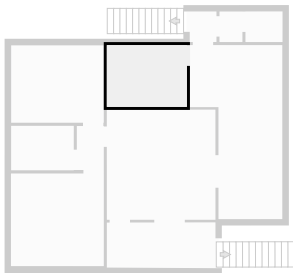

▼ **Bedroom**
1st Floor

WIDTH: 3.64 m • LENGTH: 3.04 m
AREA: 11.07 m² • PERIMETER: 13.36 m

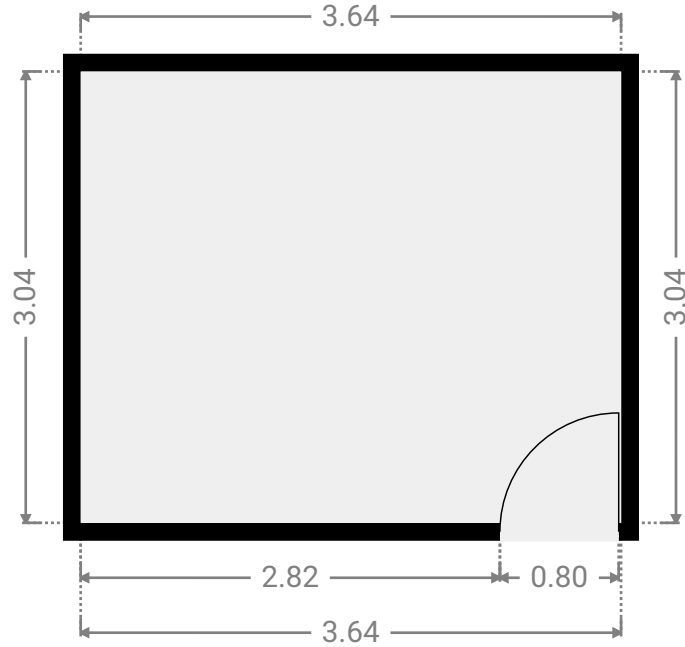
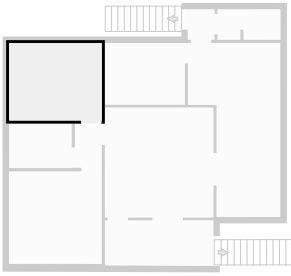

▼ **Bedroom**
1st Floor

WIDTH: 3.65 m • LENGTH: 3.64 m
AREA: 13.29 m² • PERIMETER: 14.58 m

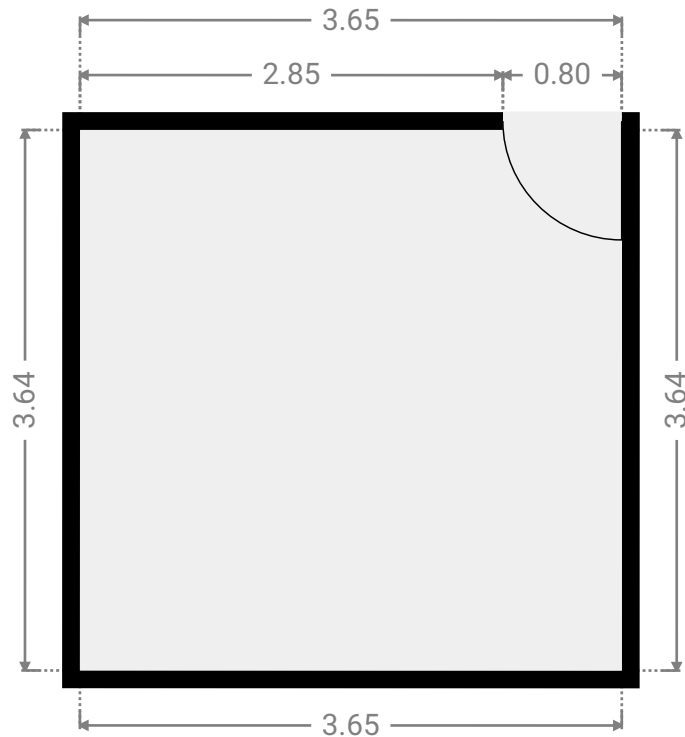
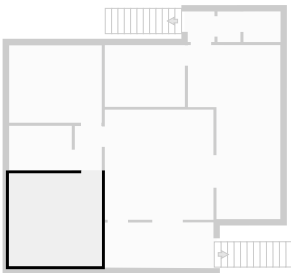

▼ **Hall**
1st Floor

WIDTH: 1.05 m • LENGTH: 1.20 m
AREA: 1.26 m² • PERIMETER: 4.50 m

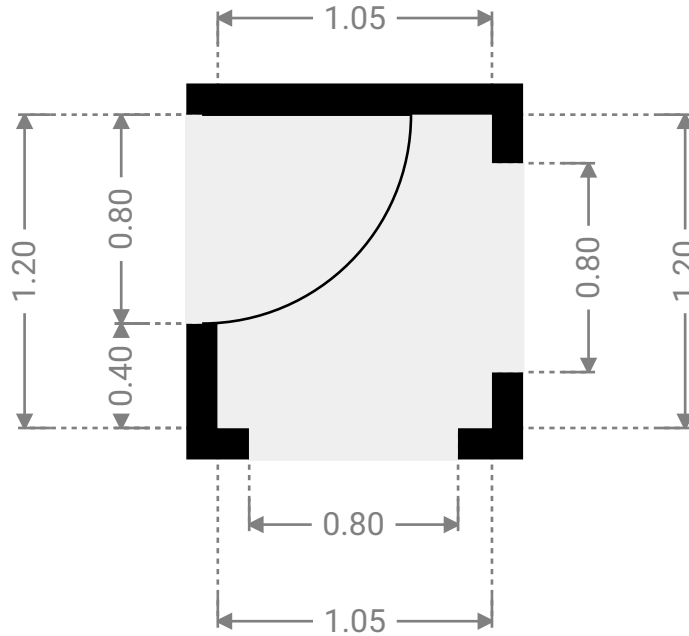

▼ **Hall**
1st Floor

WIDTH: 0.90 m • LENGTH: 1.20 m
AREA: 1.08 m² • PERIMETER: 4.20 m

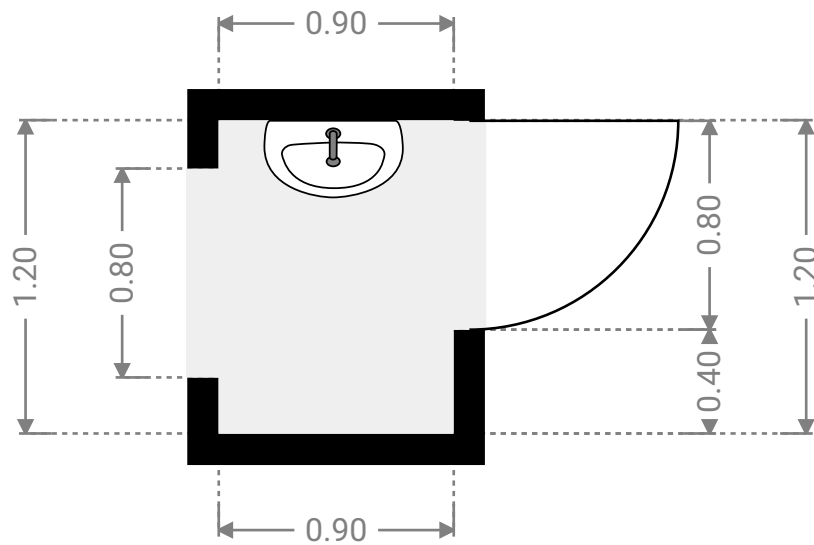

▼ Hall 1st Floor

WIDTH: 1.06 m • LENGTH: 1.73 m
AREA: 1.83 m² • PERIMETER: 5.58 m

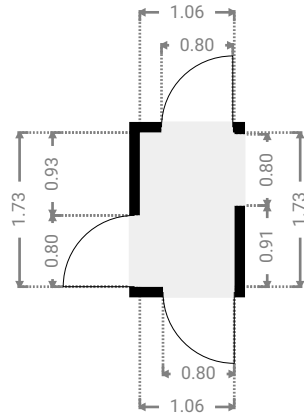
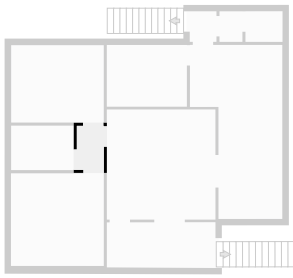

▼ Kitchen 1st Floor

WIDTH: 3.63 m • LENGTH: 6.84 m
AREA: 19.90 m² • PERIMETER: 20.94 m

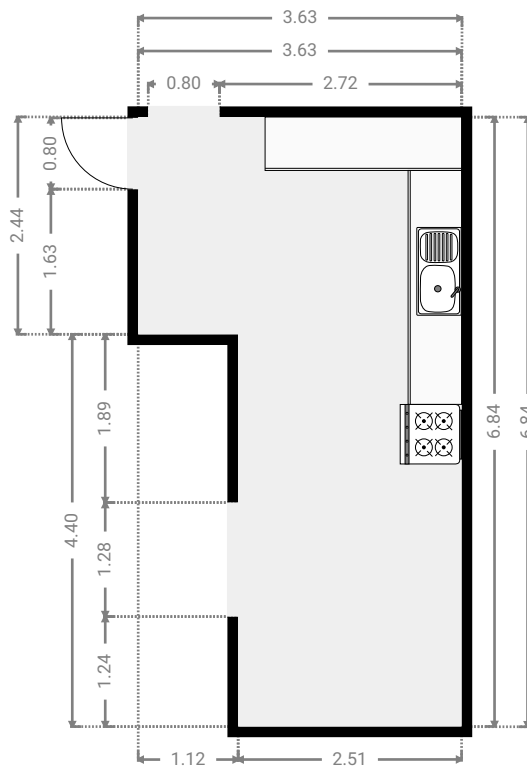

▼ Living Room
1st Floor

WIDTH: 4.27 m • LENGTH: 4.33 m
AREA: 18.49 m² • PERIMETER: 17.20 m

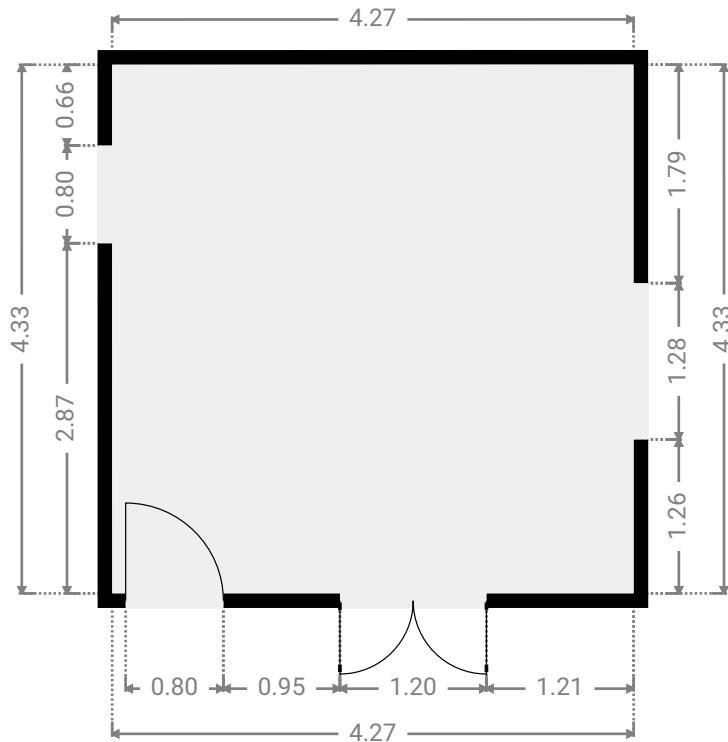
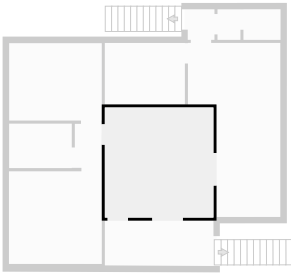

▼ Other
1st Floor

WIDTH: 4.28 m • LENGTH: 1.80 m
AREA: 7.62 m² • PERIMETER: 12.11 m

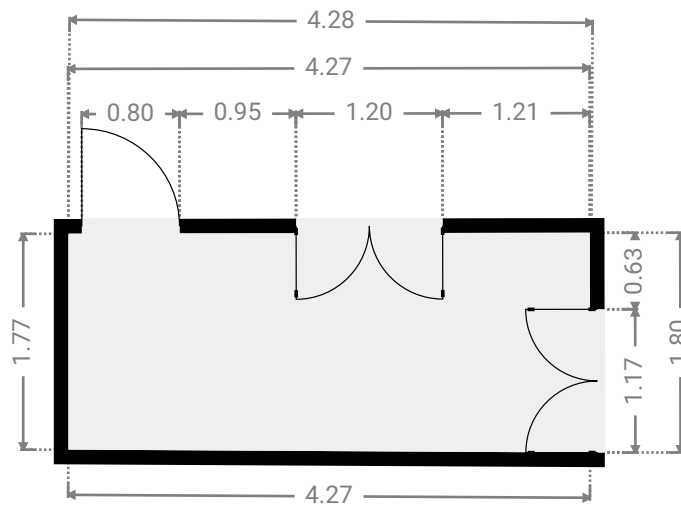

▼ Toilet
1st Floor

WIDTH: 1.46 m • LENGTH: 1.20 m
AREA: 1.75 m² • PERIMETER: 5.32 m

