

18 Separation Street

SUBMITTED BY

Ray White Rockhampton Casey
stockers@cqoz.com

CREATED ON

2022-09-29

Floors

2

▼ Ground Floor

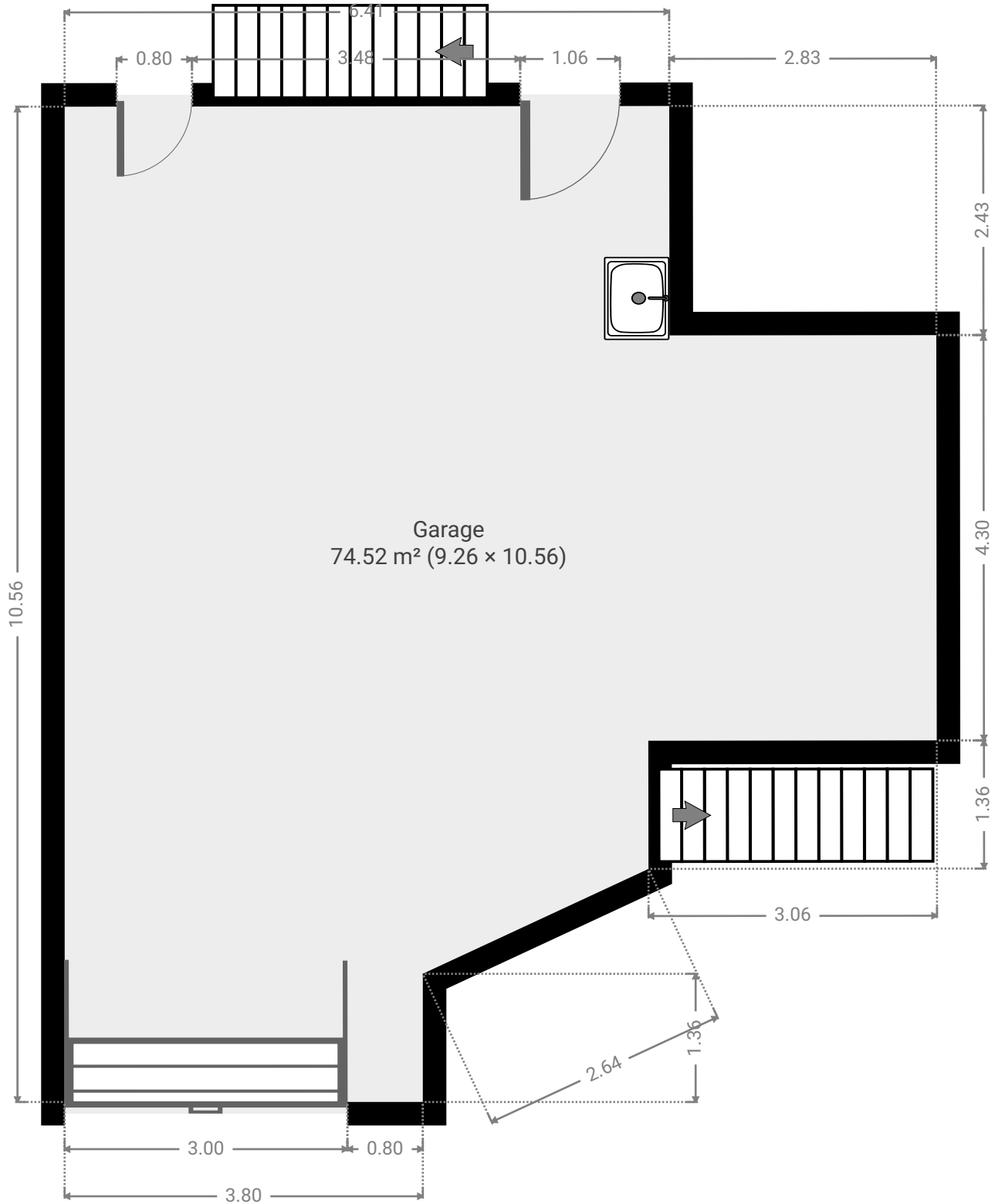

18 Separation Street

FLOORS: 2



▼ Garage Ground Floor

WIDTH: 9.26 m • LENGTH: 10.56 m
AREA: 74.52 m² • PERIMETER: 38.76 m

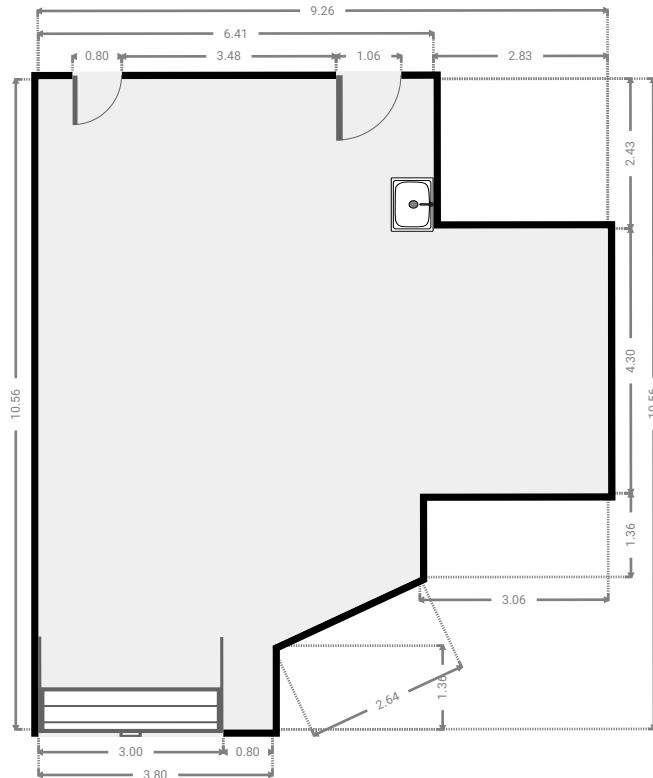
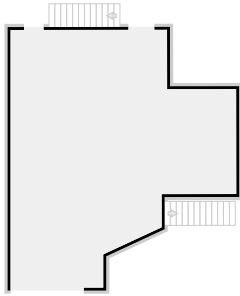

▼ 1st Floor

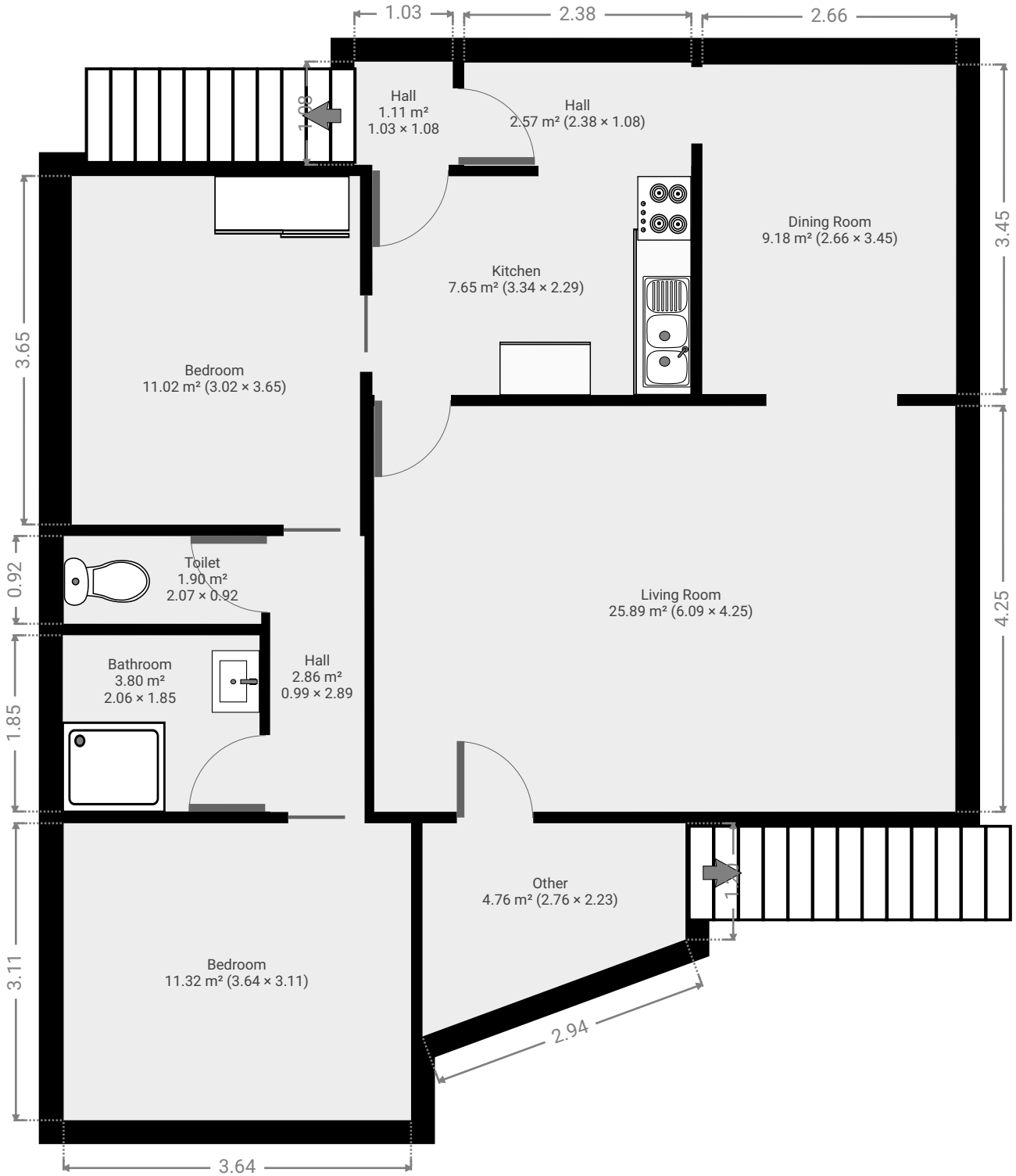

▼ Bathroom
1st Floor

WIDTH: 2.06 m • LENGTH: 1.85 m
AREA: 3.80 m² • PERIMETER: 7.81 m

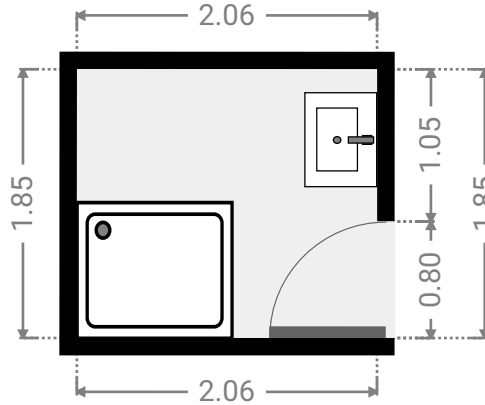
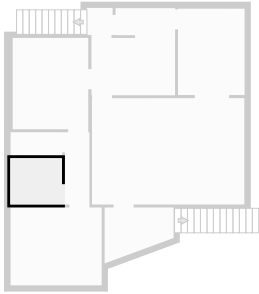

▼ Bedroom
1st Floor

WIDTH: 3.02 m • LENGTH: 3.65 m
AREA: 11.02 m² • PERIMETER: 13.34 m

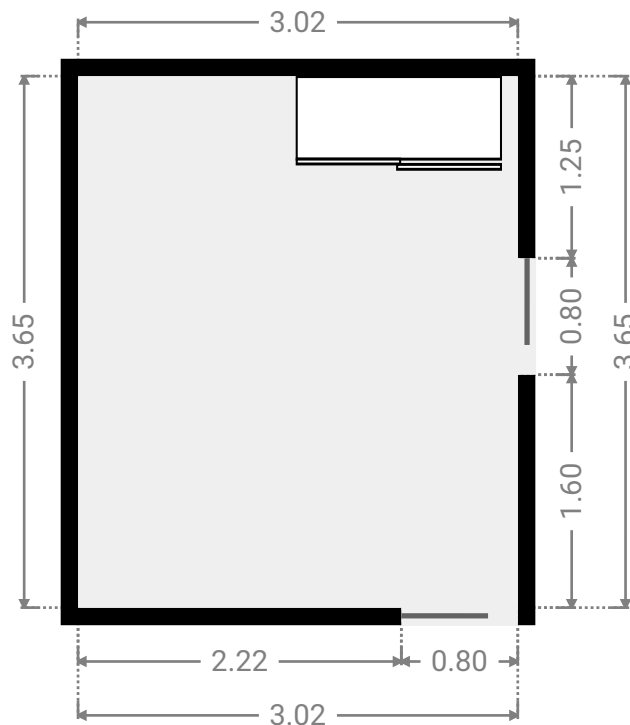
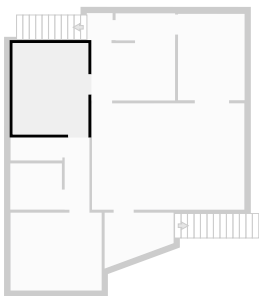

FLOORS: 2

▼ Bedroom
1st Floor

WIDTH: 3.64 m • LENGTH: 3.11 m
AREA: 11.32 m² • PERIMETER: 13.50 m

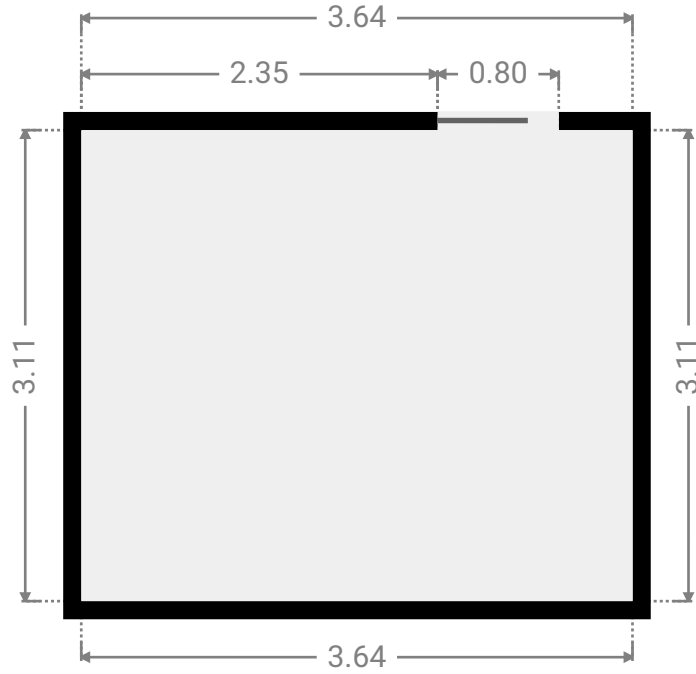
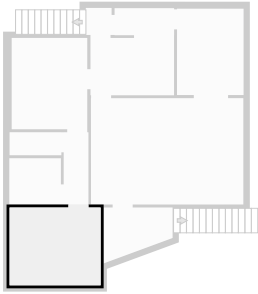

▼ Dining Room
1st Floor

WIDTH: 2.66 m • LENGTH: 3.45 m
AREA: 9.18 m² • PERIMETER: 12.22 m

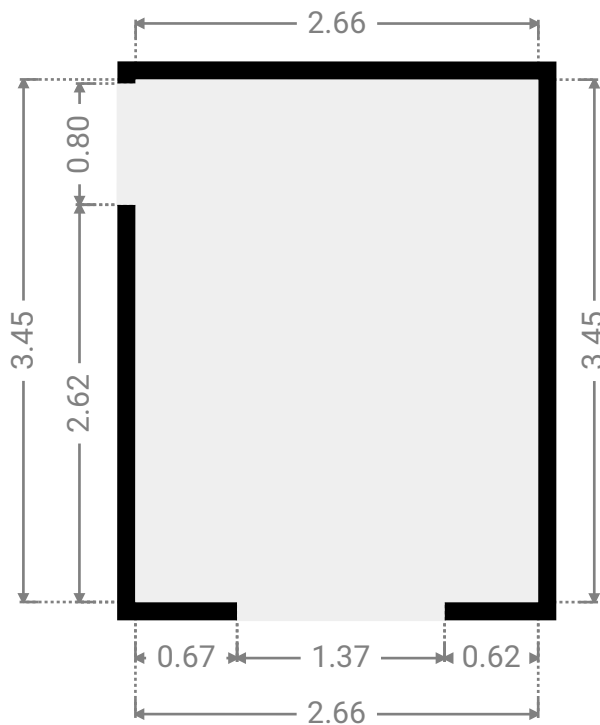
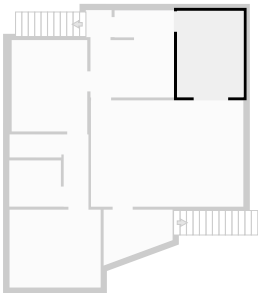

FLOORS: 2

▼ Hall
1st Floor

WIDTH: 2.38 m • LENGTH: 1.08 m
AREA: 2.57 m² • PERIMETER: 6.92 m

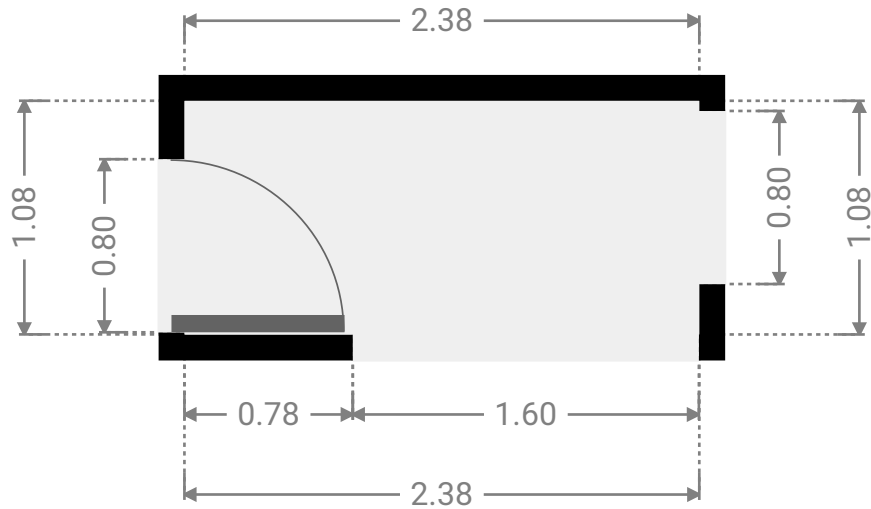
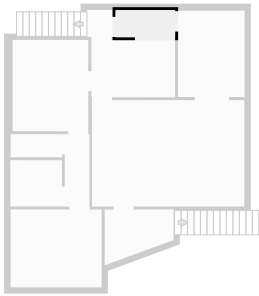

▼ Hall
1st Floor

WIDTH: 1.03 m • LENGTH: 1.08 m
AREA: 1.11 m² • PERIMETER: 4.22 m

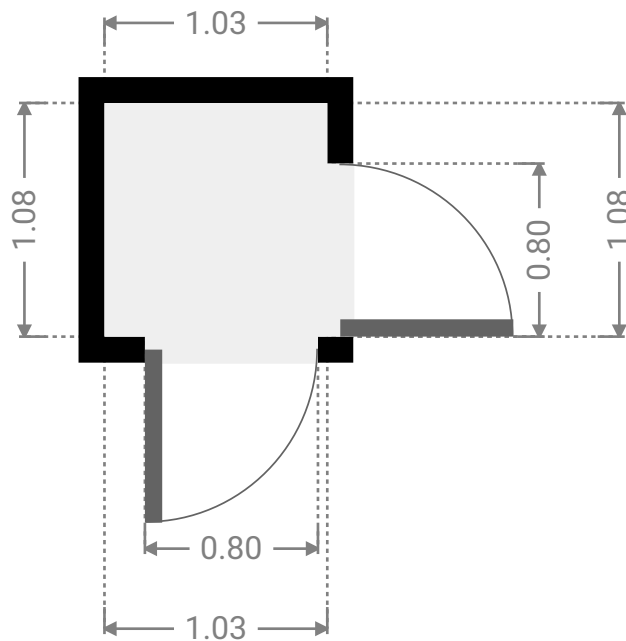
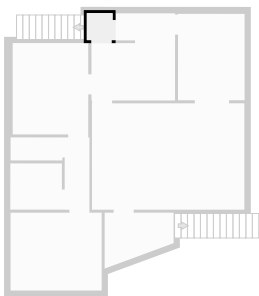

▼ Hall
1st Floor

WIDTH: 0.99 m • LENGTH: 2.89 m
AREA: 2.86 m² • PERIMETER: 7.76 m

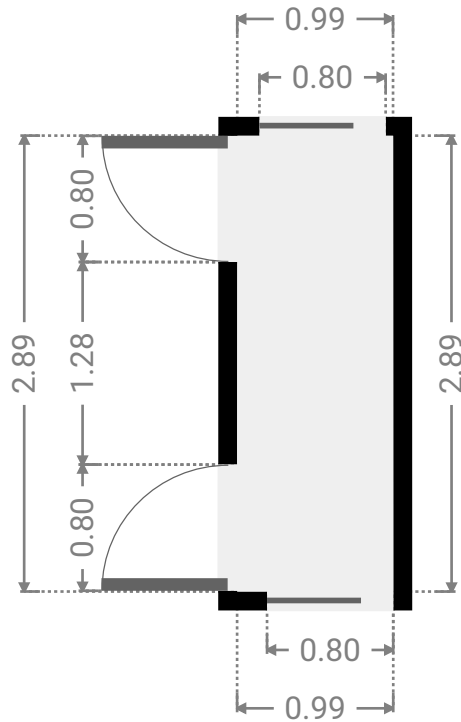
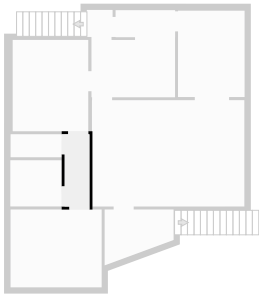

▼ Kitchen
1st Floor

WIDTH: 3.34 m • LENGTH: 2.29 m
AREA: 7.65 m² • PERIMETER: 11.26 m

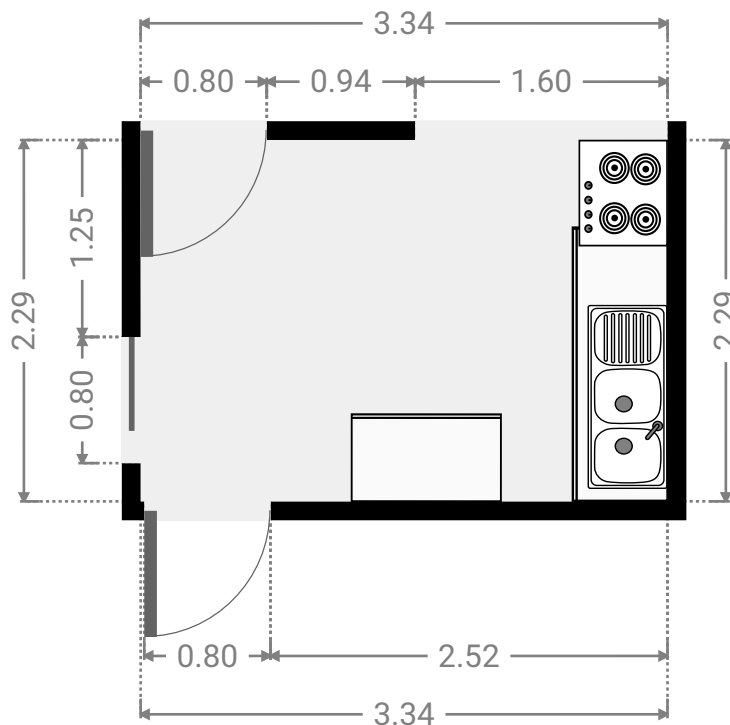
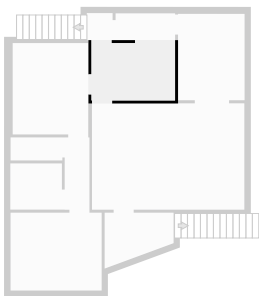

FLOORS: 2

▼ Living Room
1st Floor

WIDTH: 6.09 m • LENGTH: 4.25 m
AREA: 25.89 m² • PERIMETER: 20.68 m

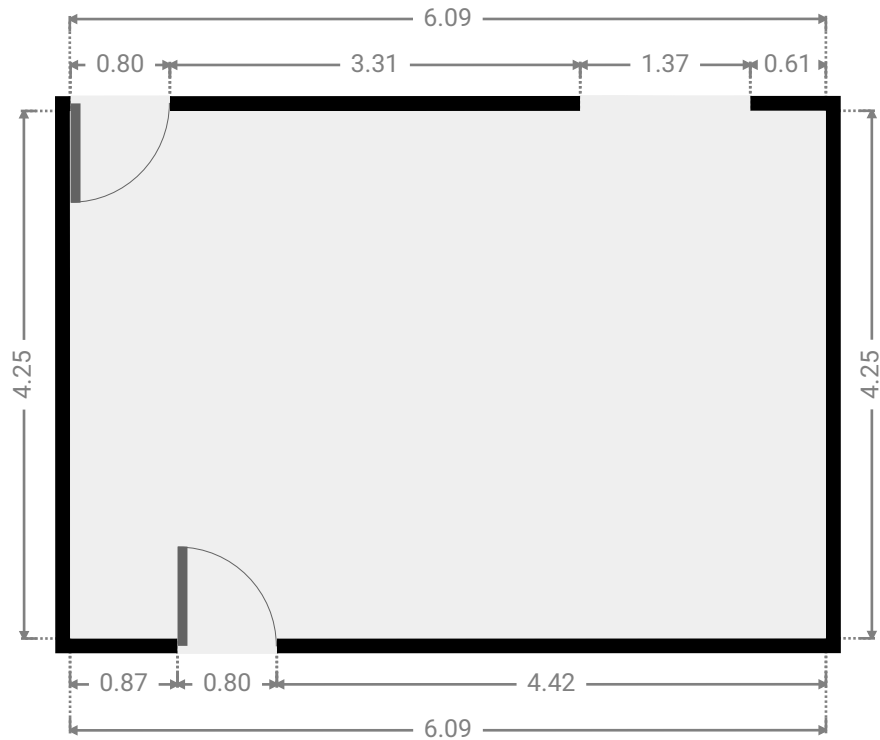
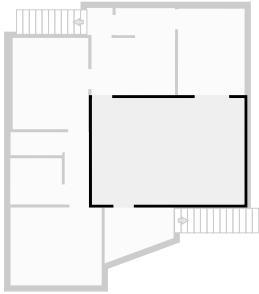

▼ Other
1st Floor

WIDTH: 2.76 m • LENGTH: 2.23 m
AREA: 4.76 m² • PERIMETER: 9.14 m

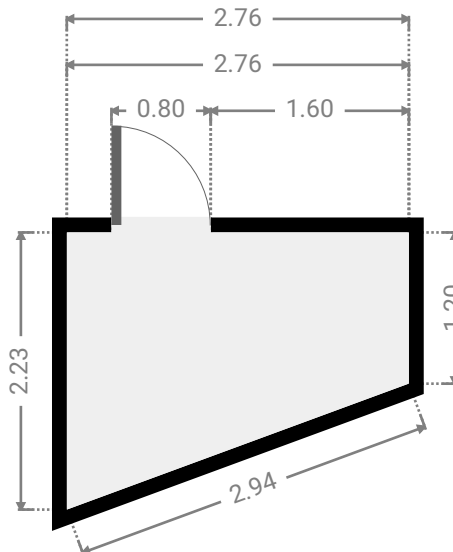
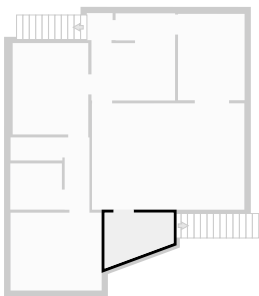

▼ Toilet 1st Floor

WIDTH: 2.07 m • LENGTH: 0.92 m
AREA: 1.90 m² • PERIMETER: 5.98 m

