

# 18 Medcraf Street

**SUBMITTED BY**

Ray White Rockhampton Casey  
stockers@cqoz.com

---

**CREATED ON**

2022-05-17

---

**Floors**

2

---

▼ Ground Floor

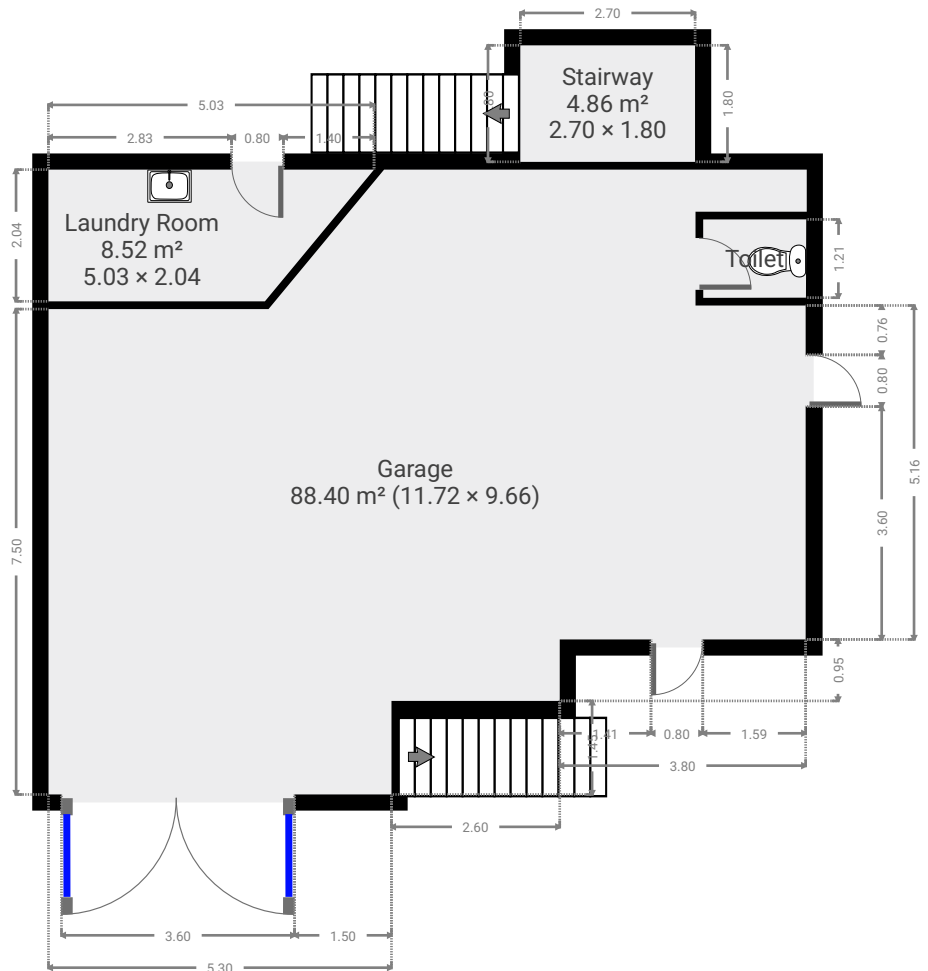
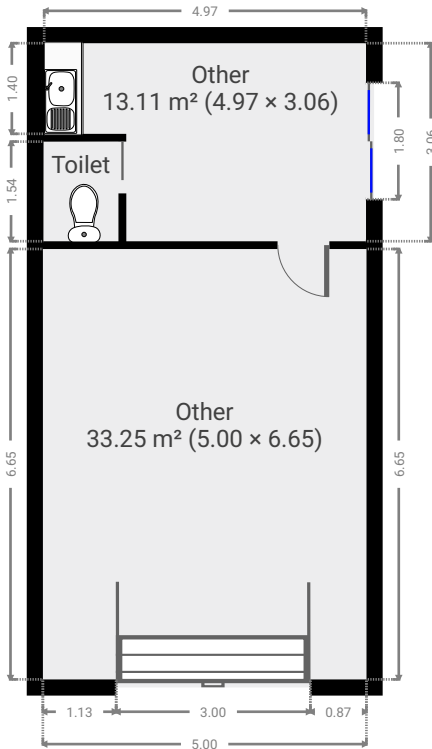

FLOORS: 2

▼ Garage  
Ground Floor

WIDTH: 11.72 m • LENGTH: 9.66 m  
AREA: 88.40 m<sup>2</sup> • PERIMETER: 45.01 m

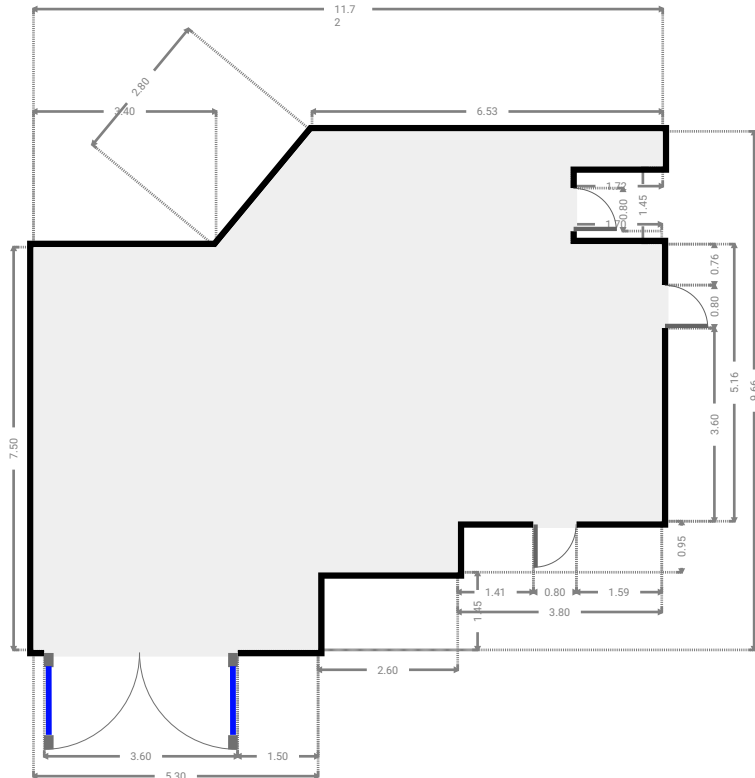
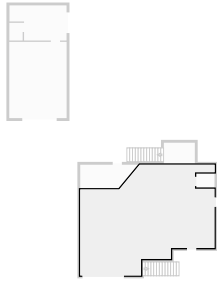

▼ Laundry Room  
Ground Floor

WIDTH: 5.03 m • LENGTH: 2.04 m  
AREA: 8.52 m<sup>2</sup> • PERIMETER: 13.06 m

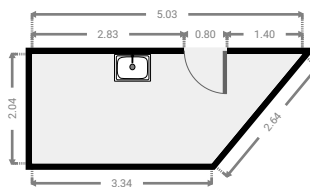
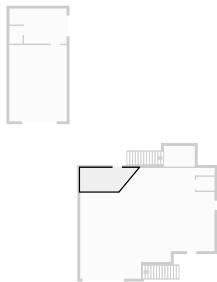

▼ Other  
Ground Floor

WIDTH: 5.00 m • LENGTH: 6.65 m  
AREA: 33.25 m<sup>2</sup> • PERIMETER: 23.30 m

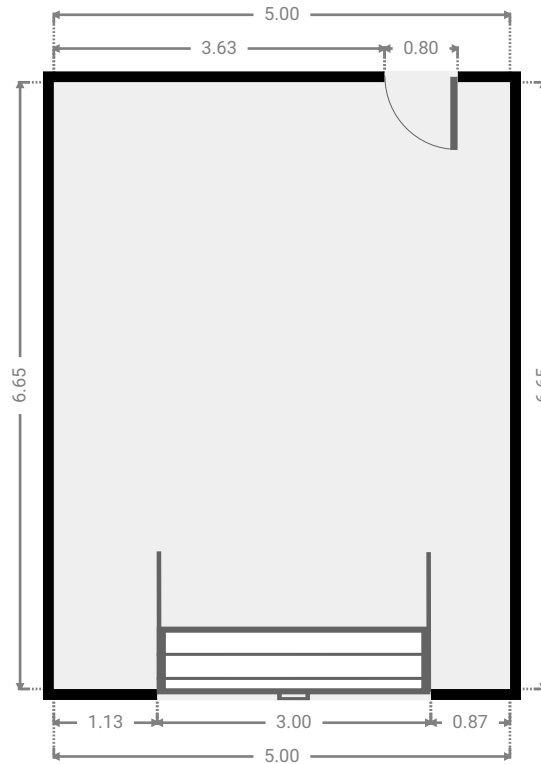
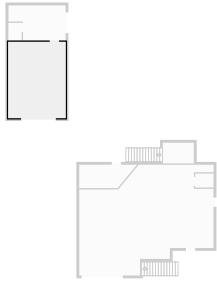

▼ Other  
Ground Floor

WIDTH: 4.97 m • LENGTH: 3.06 m  
AREA: 13.11 m<sup>2</sup> • PERIMETER: 16.07 m

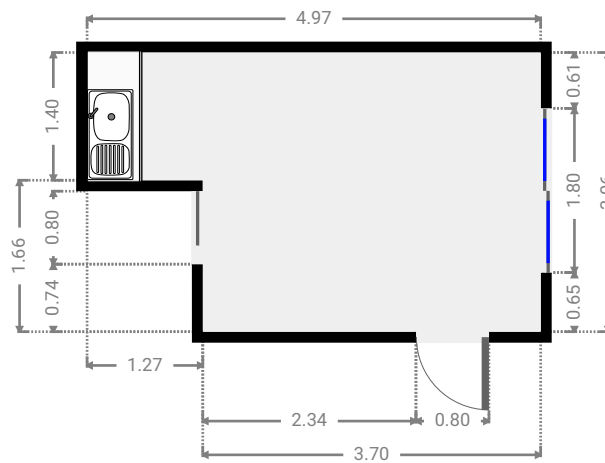
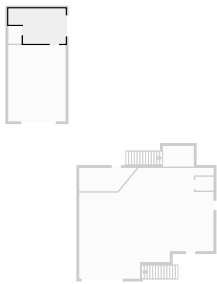

▼ **Stairway**  
Ground Floor

WIDTH: 2.70 m • LENGTH: 1.80 m  
AREA: 4.86 m<sup>2</sup> • PERIMETER: 9.00 m

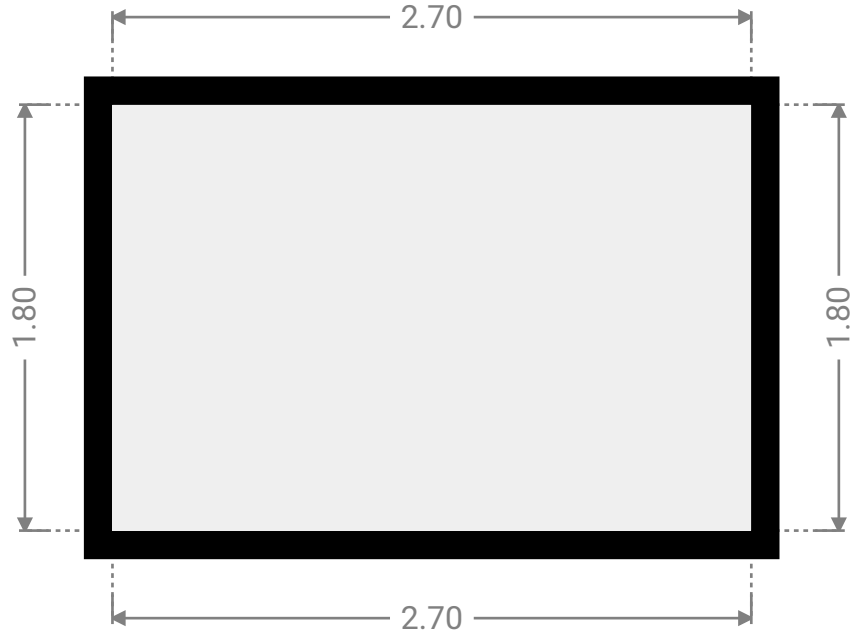
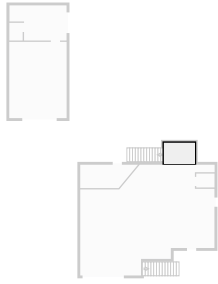

▼ **Toilet**  
Ground Floor

WIDTH: 1.59 m • LENGTH: 1.21 m  
AREA: 1.92 m<sup>2</sup> • PERIMETER: 5.60 m

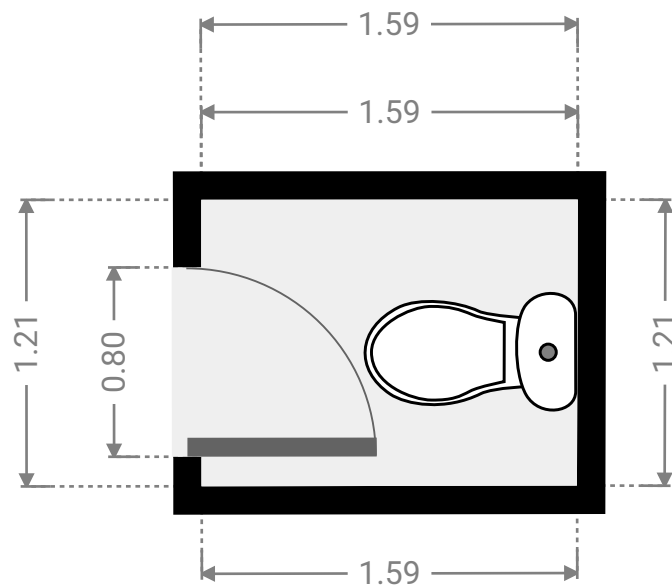
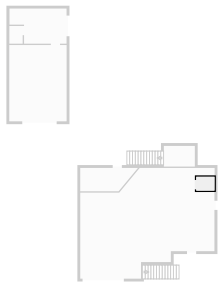

▼ Toilet  
Ground Floor

WIDTH: 1.16 m • LENGTH: 1.54 m  
AREA: 1.78 m<sup>2</sup> • PERIMETER: 5.40 m

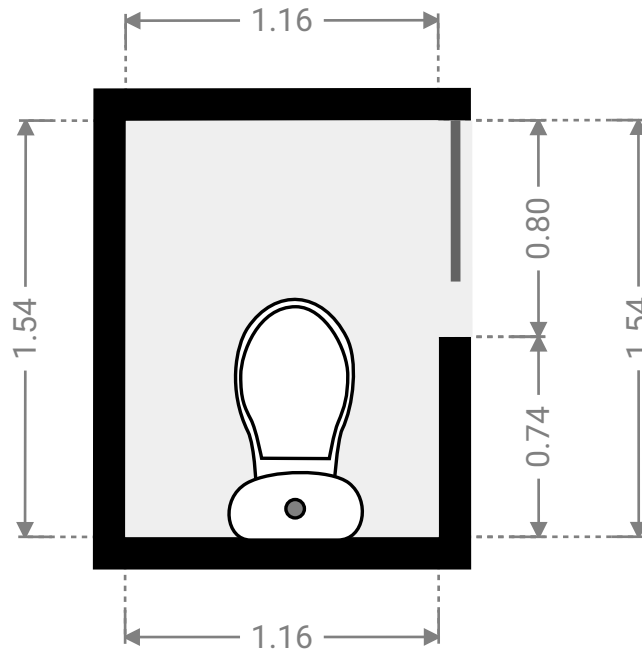
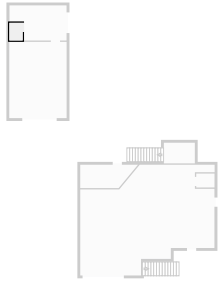

▼ 1st Floor



▼ **Bathroom**  
1st Floor

WIDTH: 2.48 m • LENGTH: 2.86 m  
AREA: 7.09 m<sup>2</sup> • PERIMETER: 10.68 m

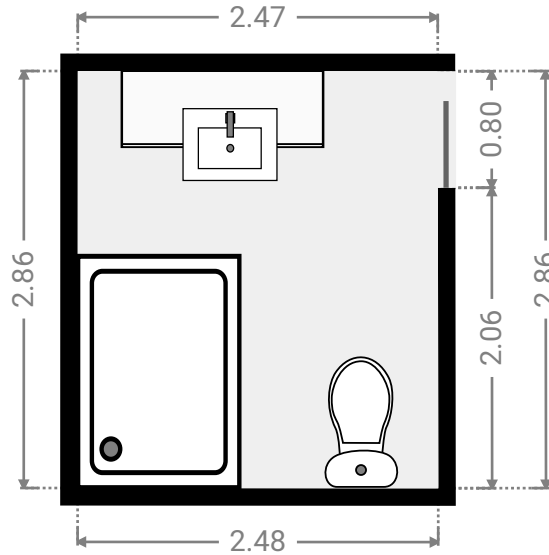
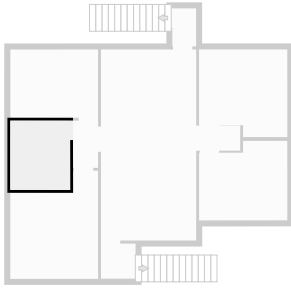

▼ **Bedroom**  
1st Floor

WIDTH: 3.65 m • LENGTH: 3.29 m  
AREA: 11.11 m<sup>2</sup> • PERIMETER: 13.88 m

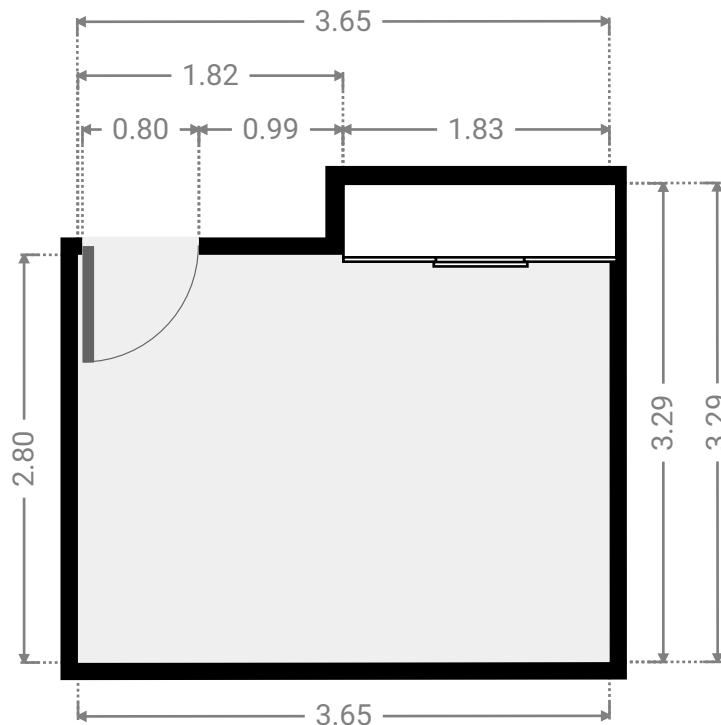
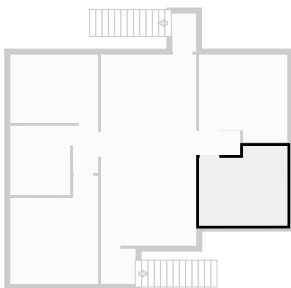



▼ **Bedroom**  
1st Floor

WIDTH: 3.65 m • LENGTH: 3.63 m  
AREA: 12.34 m<sup>2</sup> • PERIMETER: 14.55 m

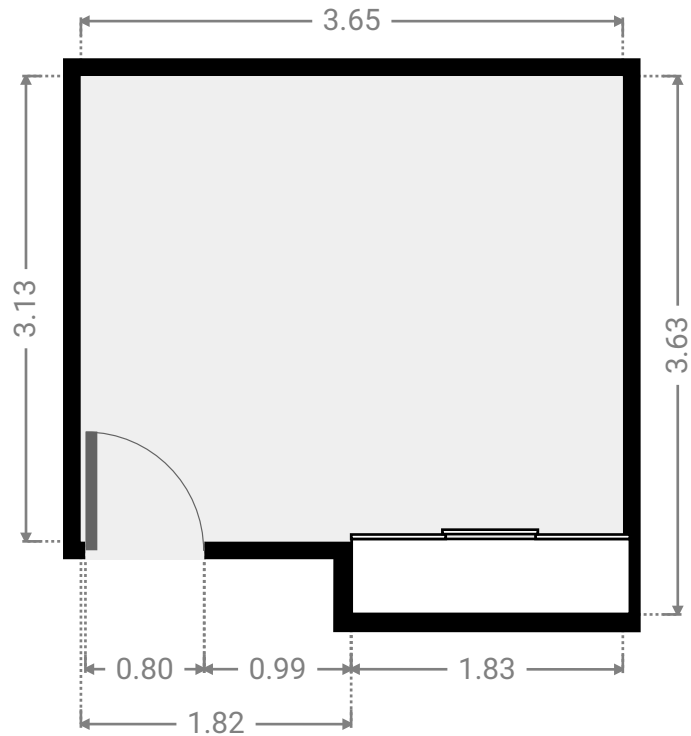
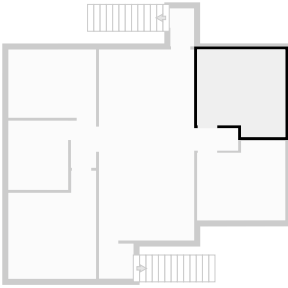

▼ **Bedroom**  
1st Floor

WIDTH: 3.63 m • LENGTH: 2.82 m  
AREA: 10.24 m<sup>2</sup> • PERIMETER: 12.90 m

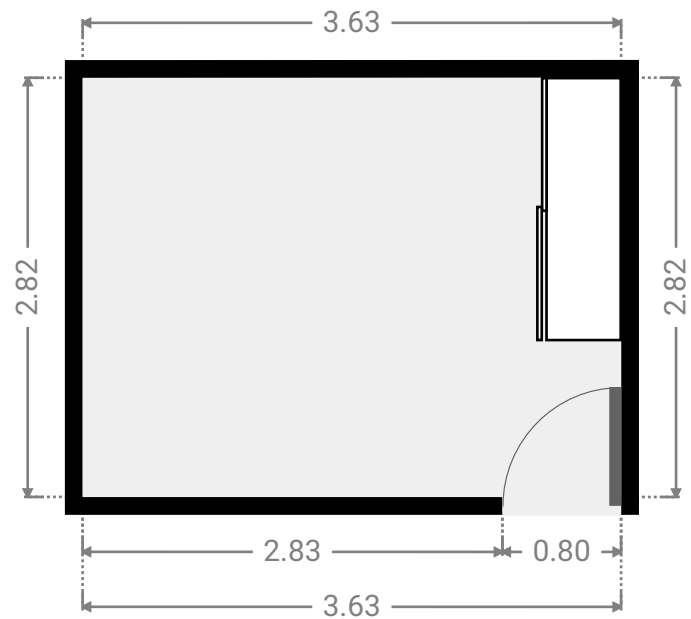
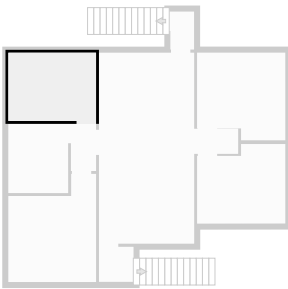

▼ **Hall**  
1st Floor

WIDTH: 1.43 m • LENGTH: 1.45 m  
AREA: 2.07 m<sup>2</sup> • PERIMETER: 5.76 m

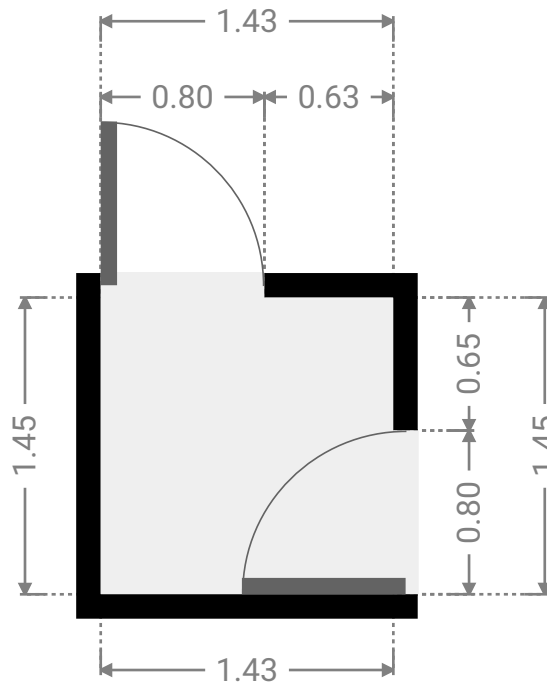
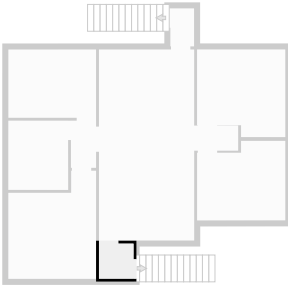

▼ **Hall**  
1st Floor

WIDTH: 1.70 m • LENGTH: 1.04 m  
AREA: 1.77 m<sup>2</sup> • PERIMETER: 5.48 m

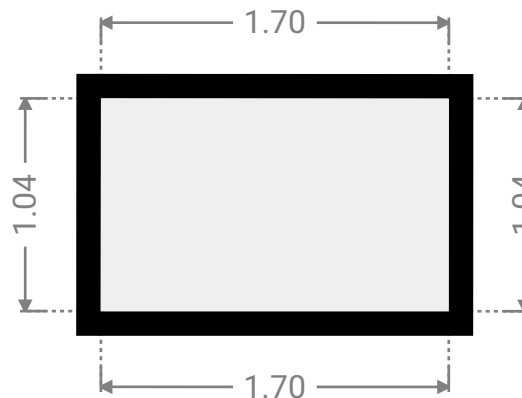
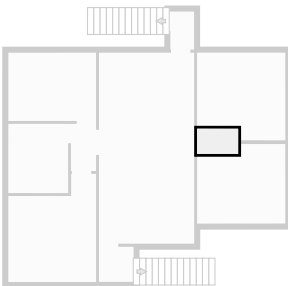

▼ **Hall**  
1st Floor

WIDTH: 0.98 m • LENGTH: 1.57 m  
AREA: 1.54 m<sup>2</sup> • PERIMETER: 5.10 m

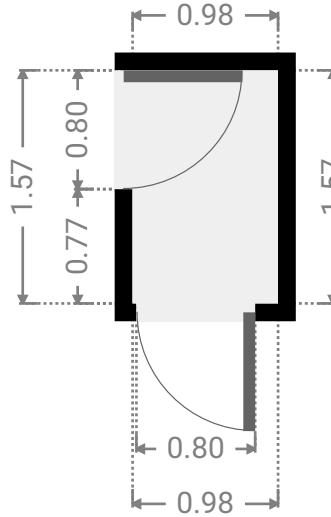
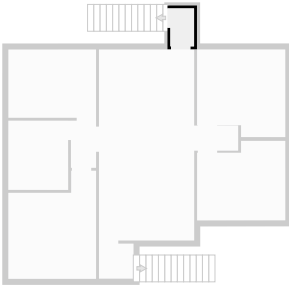

▼ **Hall**  
1st Floor

WIDTH: 1.04 m • LENGTH: 1.95 m  
AREA: 2.03 m<sup>2</sup> • PERIMETER: 5.98 m

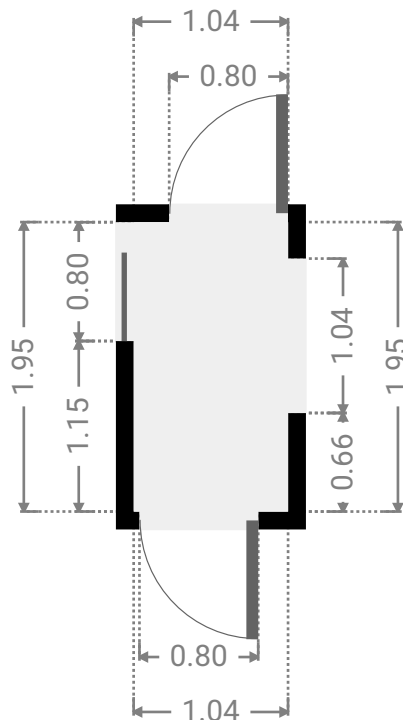
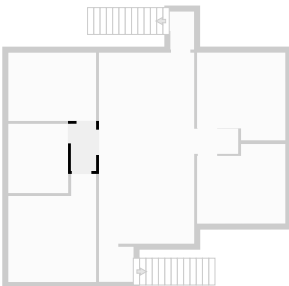

▼ **Living Room**  
1st Floor

WIDTH: 3.94 m • LENGTH: 7.90 m  
AREA: 31.13 m<sup>2</sup> • PERIMETER: 23.68 m

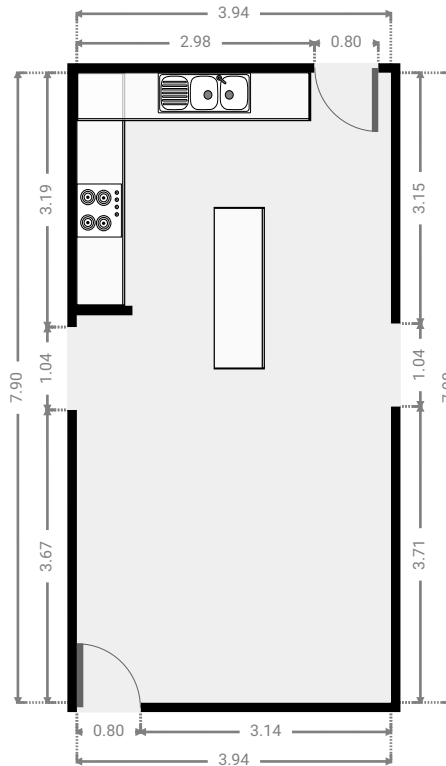
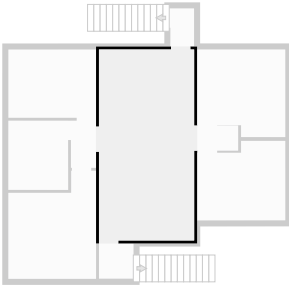

▼ **Primary Bedroom**  
1st Floor

WIDTH: 3.63 m • LENGTH: 4.47 m  
AREA: 13.86 m<sup>2</sup> • PERIMETER: 16.21 m

