

# 18 Laird Avenue

Created on  
2021-07-20

Floors  
1

## ▼ Ground Floor

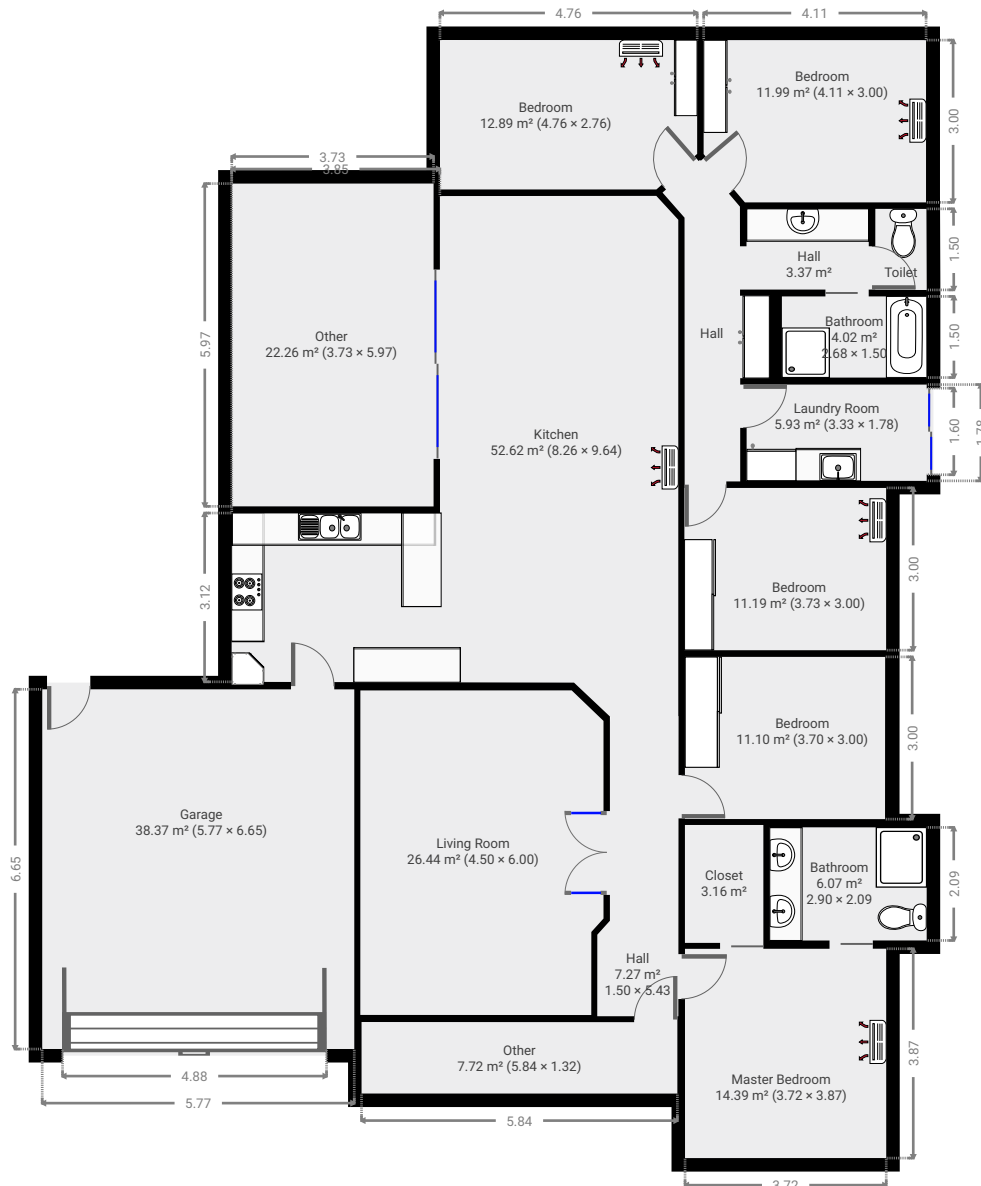
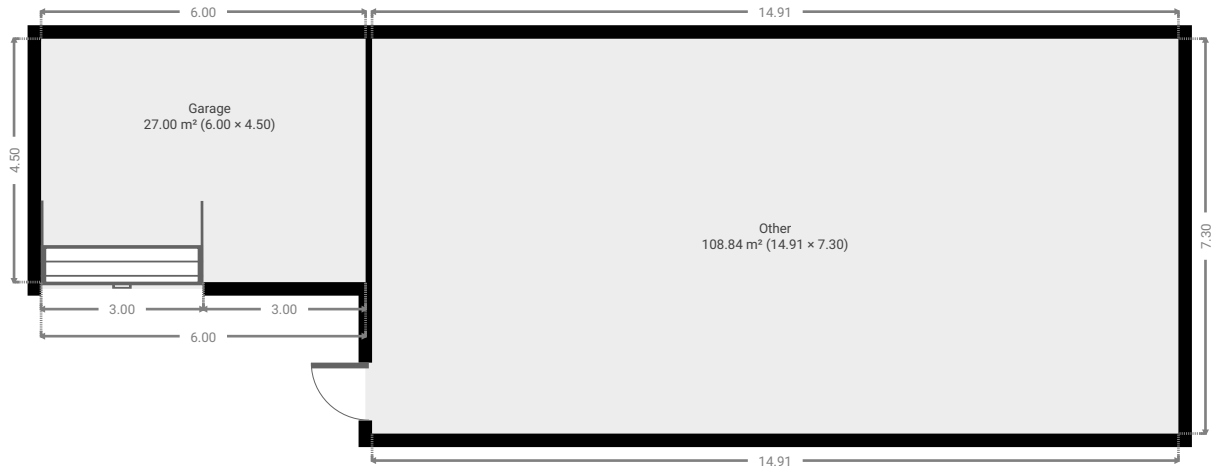

▼ Bathroom  
Ground Floor

WIDTH: 2.68 m • LENGTH: 1.50 m  
AREA: 4.02 m<sup>2</sup> • PERIMETER: 8.36 m

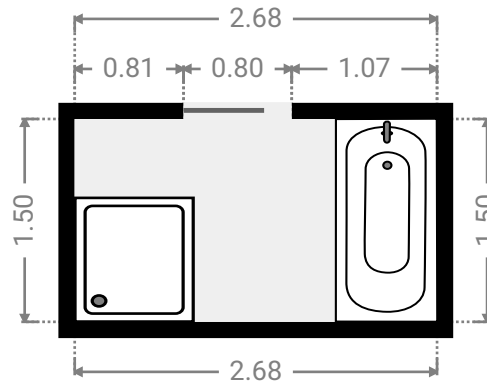
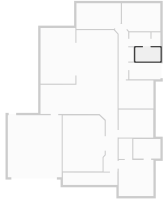

▼ Other  
Ground Floor

WIDTH: 5.84 m • LENGTH: 1.32 m  
AREA: 7.72 m<sup>2</sup> • PERIMETER: 14.32 m

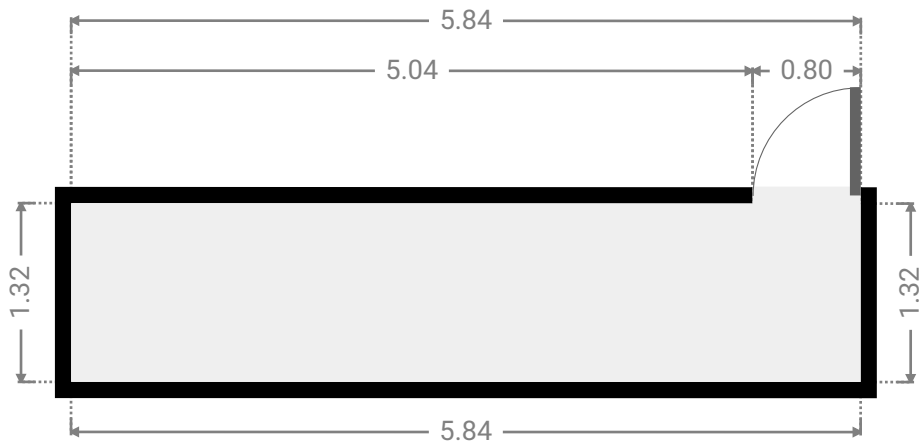
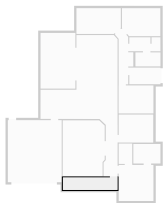

▼ **Garage**  
Ground Floor

WIDTH: 5.77 m • LENGTH: 6.65 m  
AREA: 38.37 m<sup>2</sup> • PERIMETER: 24.84 m

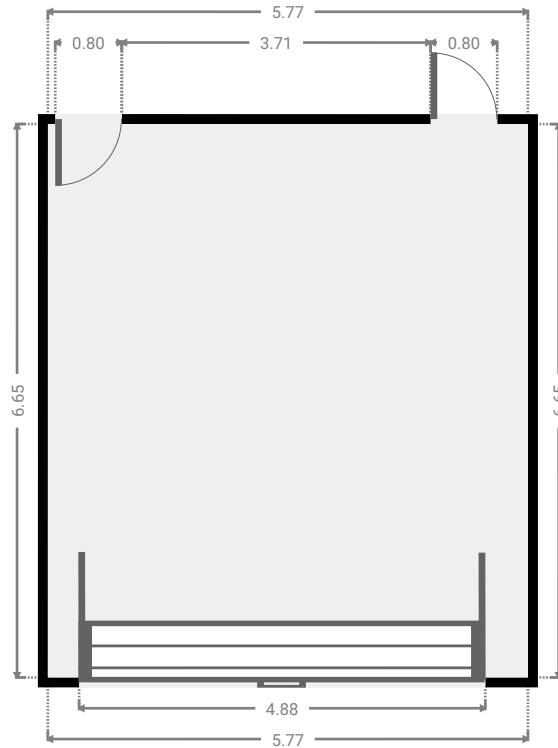

▼ **Garage**  
Ground Floor

WIDTH: 6.00 m • LENGTH: 4.50 m  
AREA: 27.00 m<sup>2</sup> • PERIMETER: 21.00 m

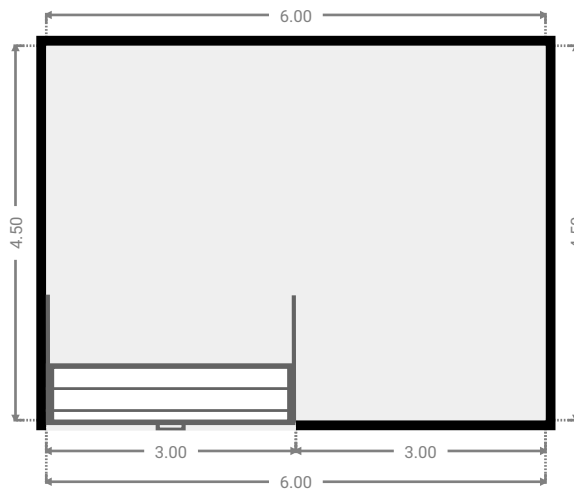
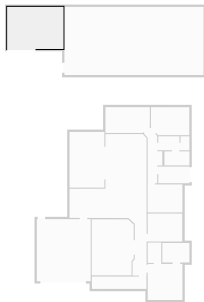

▼ Other  
Ground Floor

WIDTH: 14.91 m • LENGTH: 7.30 m  
AREA: 108.84 m<sup>2</sup> • PERIMETER: 44.42 m



▼ Other  
Ground Floor

WIDTH: 3.73 m • LENGTH: 5.97 m  
AREA: 22.26 m<sup>2</sup> • PERIMETER: 19.40 m

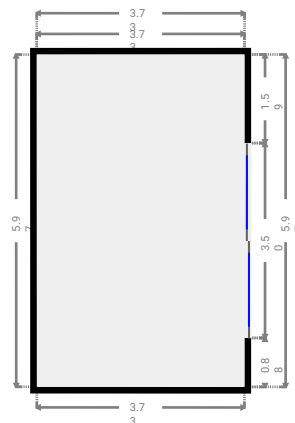
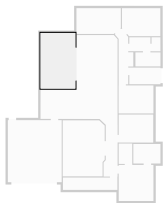

▼ **Bedroom**  
Ground Floor

WIDTH: 4.76 m • LENGTH: 2.76 m  
AREA: 12.89 m<sup>2</sup> • PERIMETER: 14.63 m

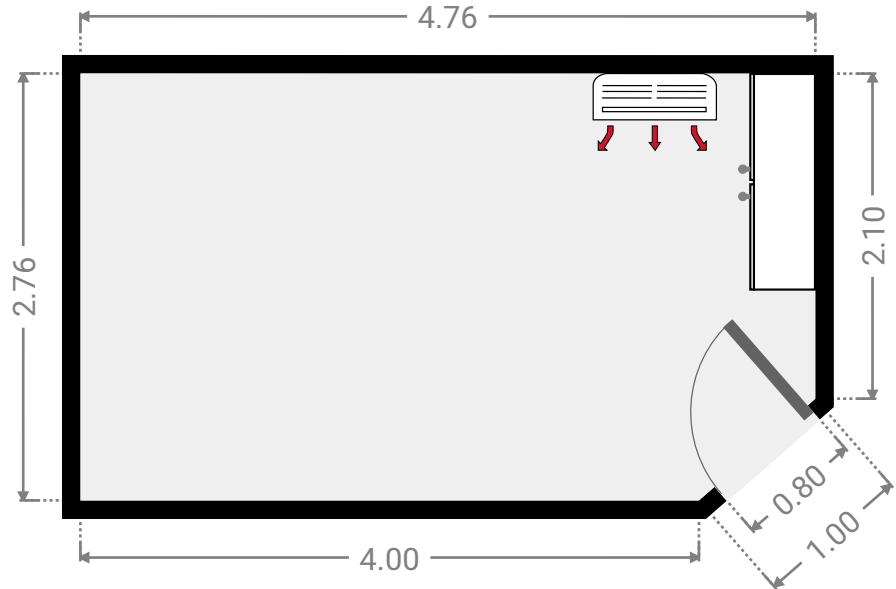

▼ **Bedroom**  
Ground Floor

WIDTH: 4.11 m • LENGTH: 3.00 m  
AREA: 11.99 m<sup>2</sup> • PERIMETER: 13.74 m

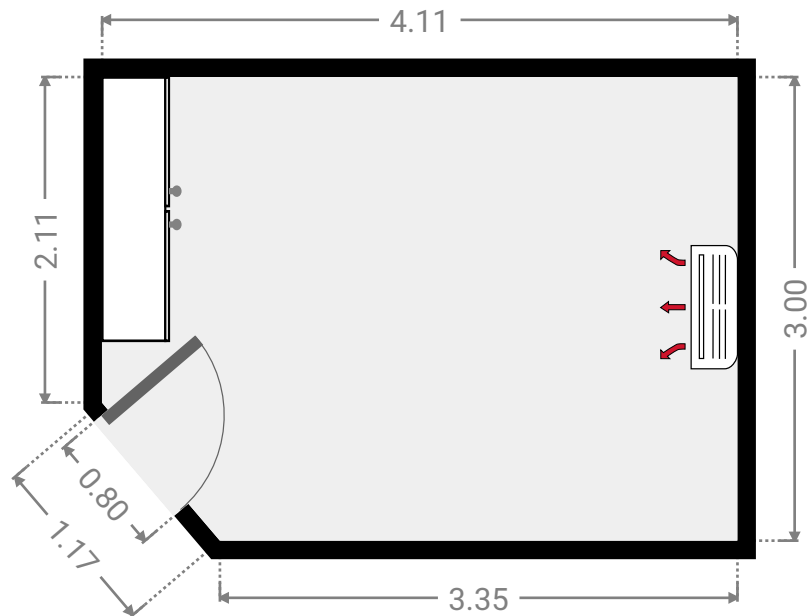

▼ **Toilet**  
Ground Floor

WIDTH: 0.95 m • LENGTH: 1.50 m  
AREA: 1.42 m<sup>2</sup> • PERIMETER: 4.89 m

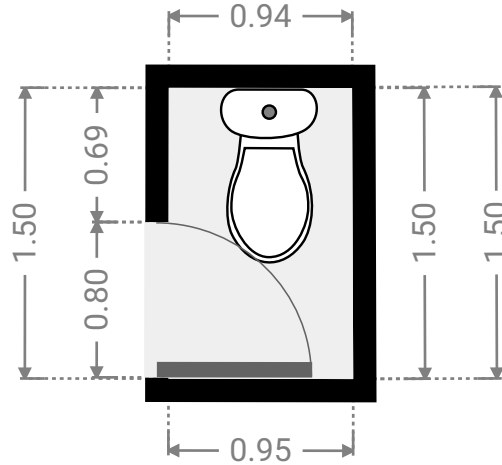

▼ **Hall**  
Ground Floor

WIDTH: 2.26 m • LENGTH: 1.49 m  
AREA: 3.37 m<sup>2</sup> • PERIMETER: 7.50 m

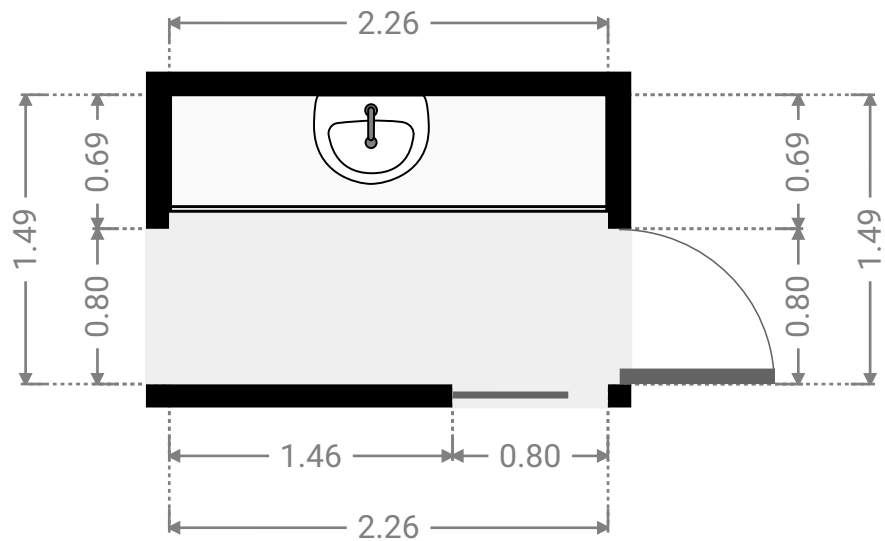

▼ Hall  
Ground Floor

WIDTH: 1.50 m • LENGTH: 5.43 m  
AREA: 7.27 m<sup>2</sup> • PERIMETER: 13.72 m

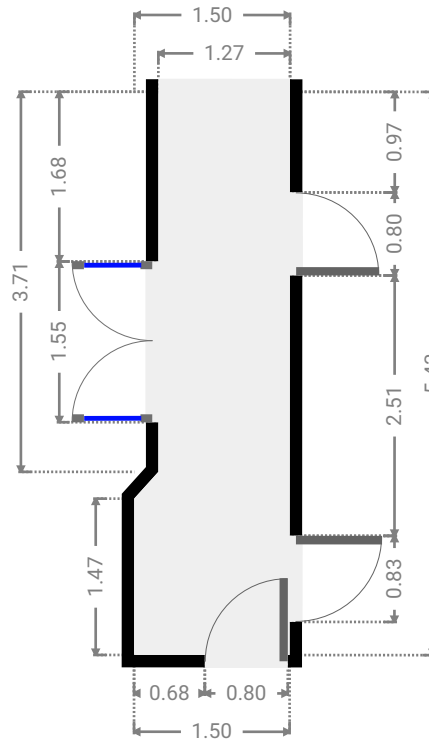

▼ Laundry Room  
Ground Floor

WIDTH: 3.33 m • LENGTH: 1.78 m  
AREA: 5.93 m<sup>2</sup> • PERIMETER: 10.22 m

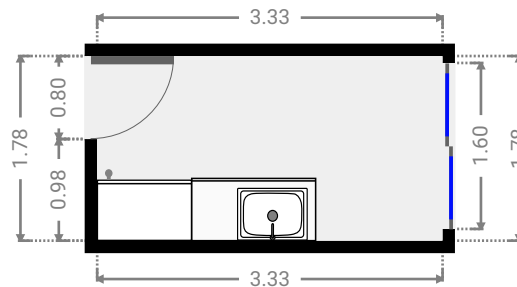



▼ **Hall**  
Ground Floor

WIDTH: 1.97 m • LENGTH: 5.95 m  
AREA: 6.74 m<sup>2</sup> • PERIMETER: 14.74 m

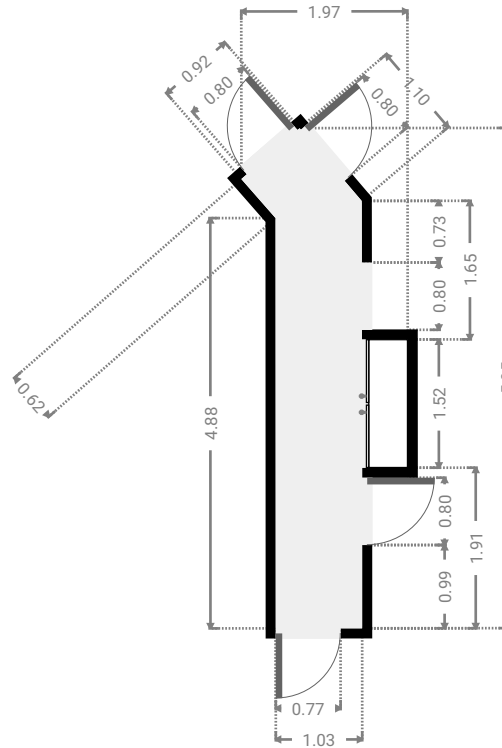

▼ **Bedroom**  
Ground Floor

WIDTH: 3.73 m • LENGTH: 3.00 m  
AREA: 11.19 m<sup>2</sup> • PERIMETER: 13.46 m

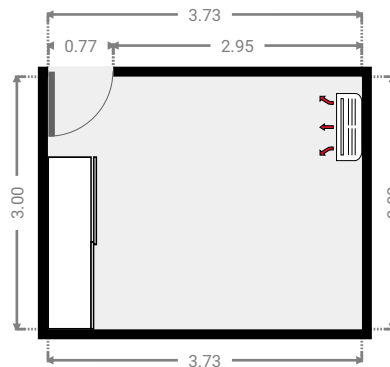

▼ **Kitchen**  
Ground Floor

WIDTH: 8.26 m • LENGTH: 9.64 m  
AREA: 52.62 m<sup>2</sup> • PERIMETER: 35.15 m

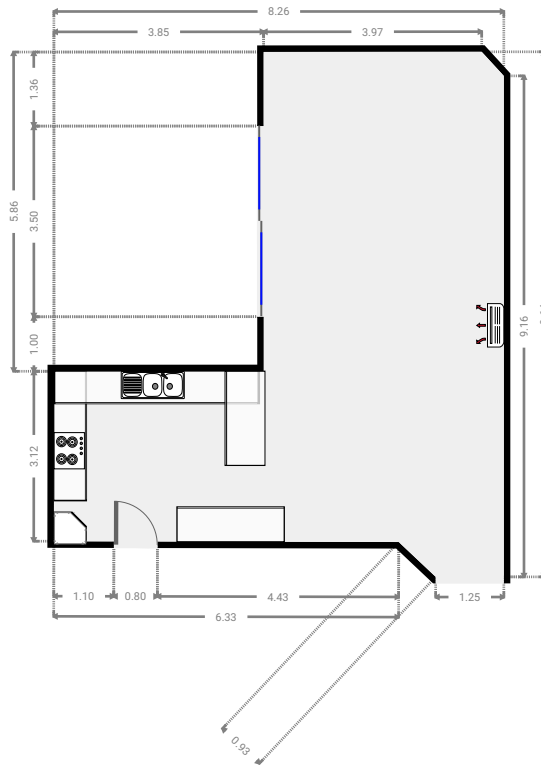
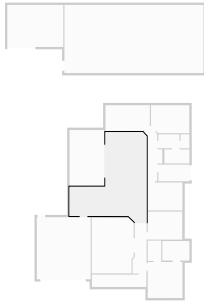

▼ **Bedroom**  
Ground Floor

WIDTH: 3.70 m • LENGTH: 3.00 m  
AREA: 11.10 m<sup>2</sup> • PERIMETER: 13.40 m

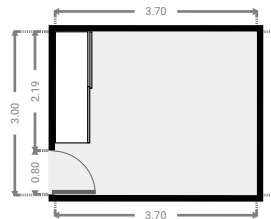

▼ **Bathroom**  
Ground Floor

WIDTH: 2.90 m • LENGTH: 2.09 m  
AREA: 6.07 m<sup>2</sup> • PERIMETER: 9.98 m

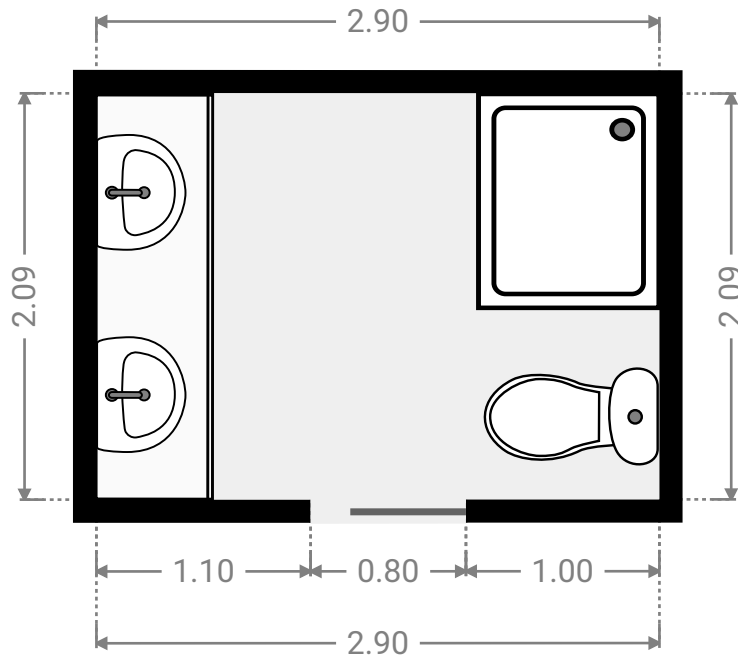

▼ **Closet**  
Ground Floor

WIDTH: 1.45 m • LENGTH: 2.18 m  
AREA: 3.16 m<sup>2</sup> • PERIMETER: 7.26 m

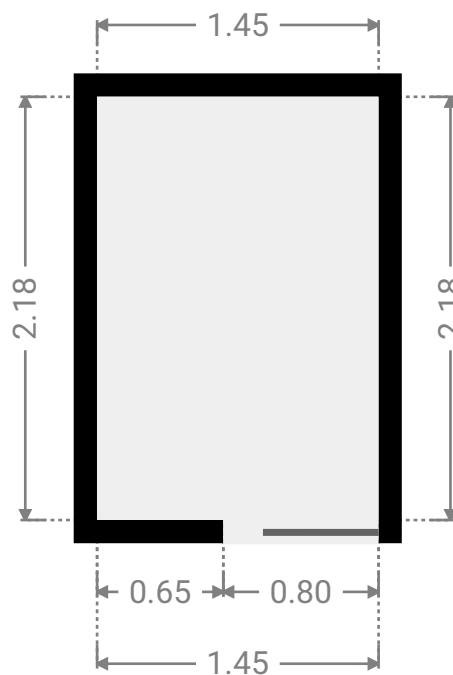

▼ Master Bedroom  
Ground Floor

WIDTH: 3.72 m • LENGTH: 3.87 m  
AREA: 14.39 m<sup>2</sup> • PERIMETER: 15.18 m

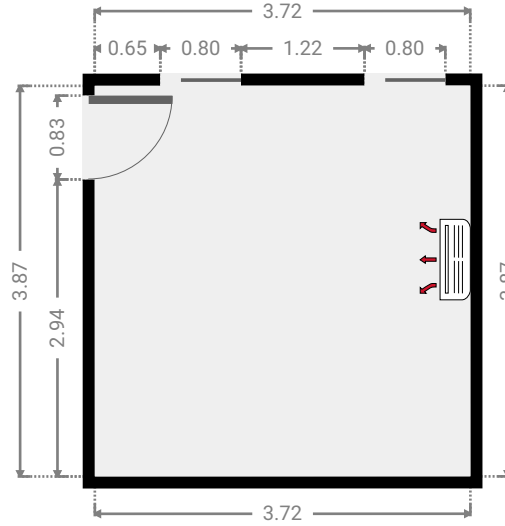

▼ Living Room  
Ground Floor

WIDTH: 4.50 m • LENGTH: 6.00 m  
AREA: 26.44 m<sup>2</sup> • PERIMETER: 20.52 m

