

18 Bowen Terrace

SUBMITTED BY

Ray White Rockhampton Casey
stockers@cqoz.com

CREATED ON

2022-12-21

Floors

2

▼ Ground Floor

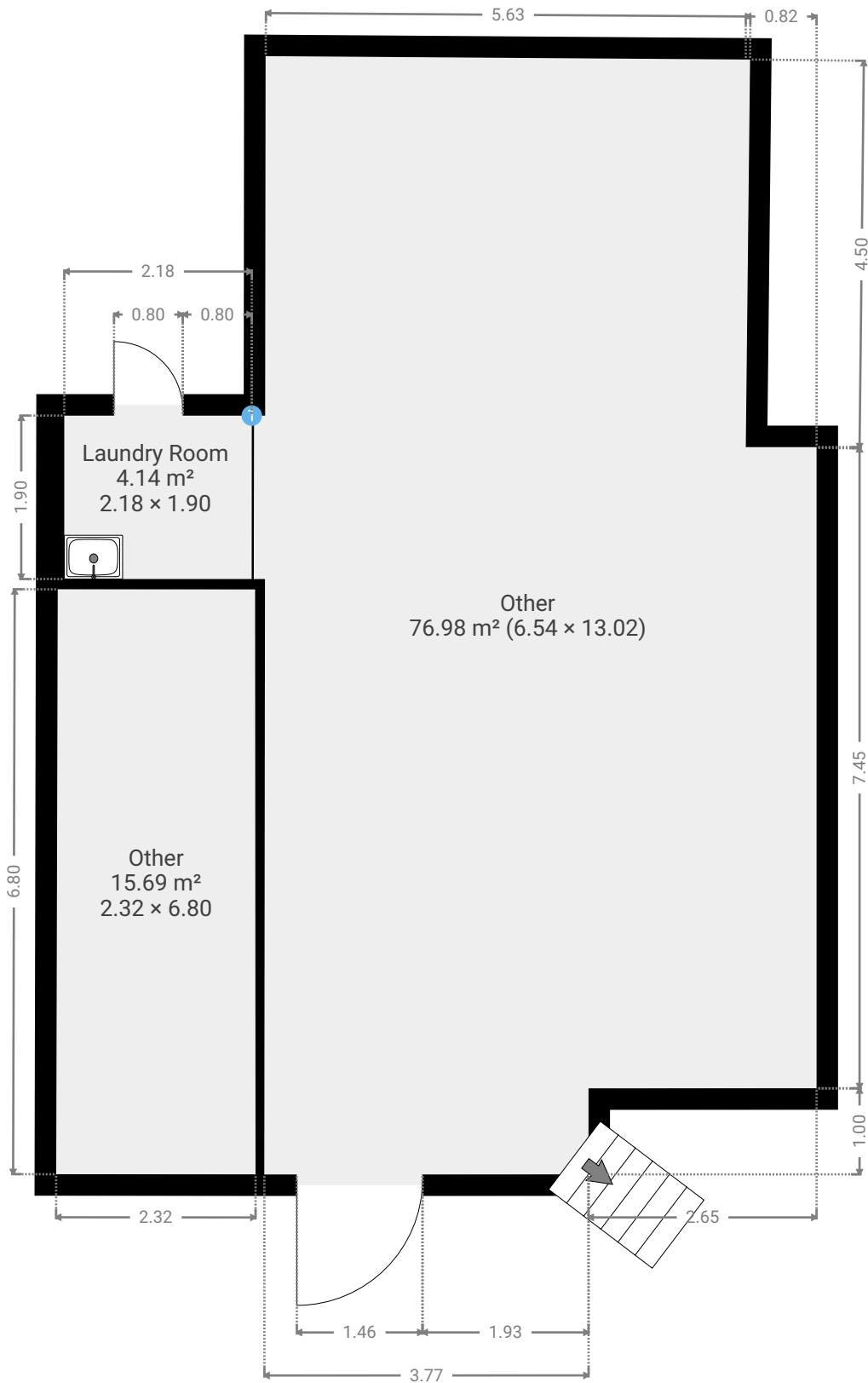

▼ Laundry Room Ground Floor

WIDTH: 2.18 m • LENGTH: 1.90 m
AREA: 4.14 m² • PERIMETER: 8.16 m

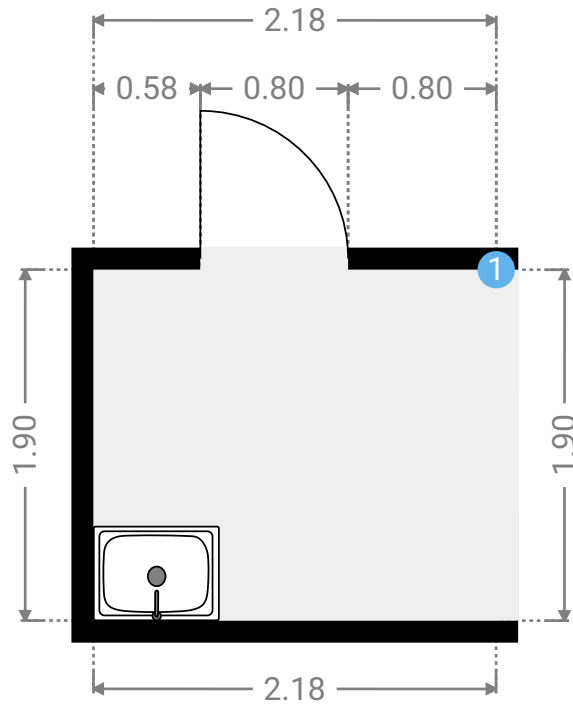
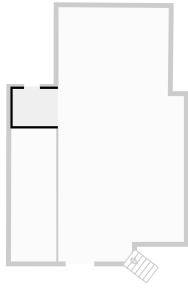

▼ Laundry Room/Ground Floor

1 OPENING

Height
0.00 m



18 Bowen Terrace

FLOORS: 2

▼ Other Ground Floor

WIDTH: 2.32 m • LENGTH: 6.80 m
AREA: 15.69 m² • PERIMETER: 18.21 m

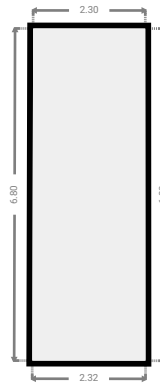
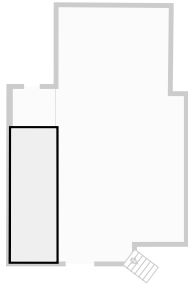

▼ Other Ground Floor

WIDTH: 6.54 m • LENGTH: 13.02 m
AREA: 76.98 m² • PERIMETER: 38.84 m

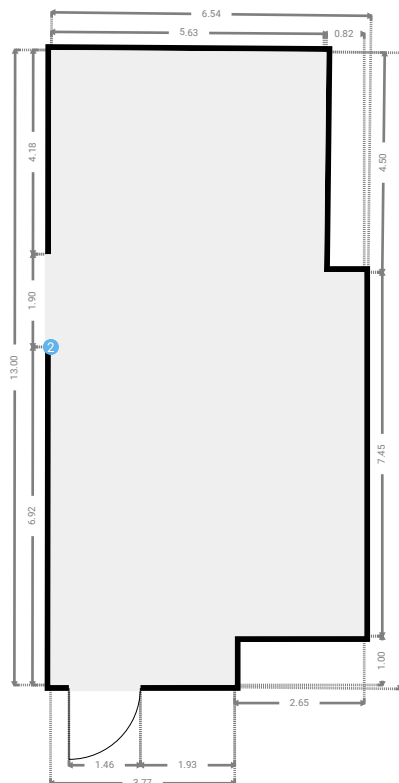
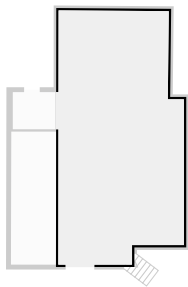

▼ 1st Floor

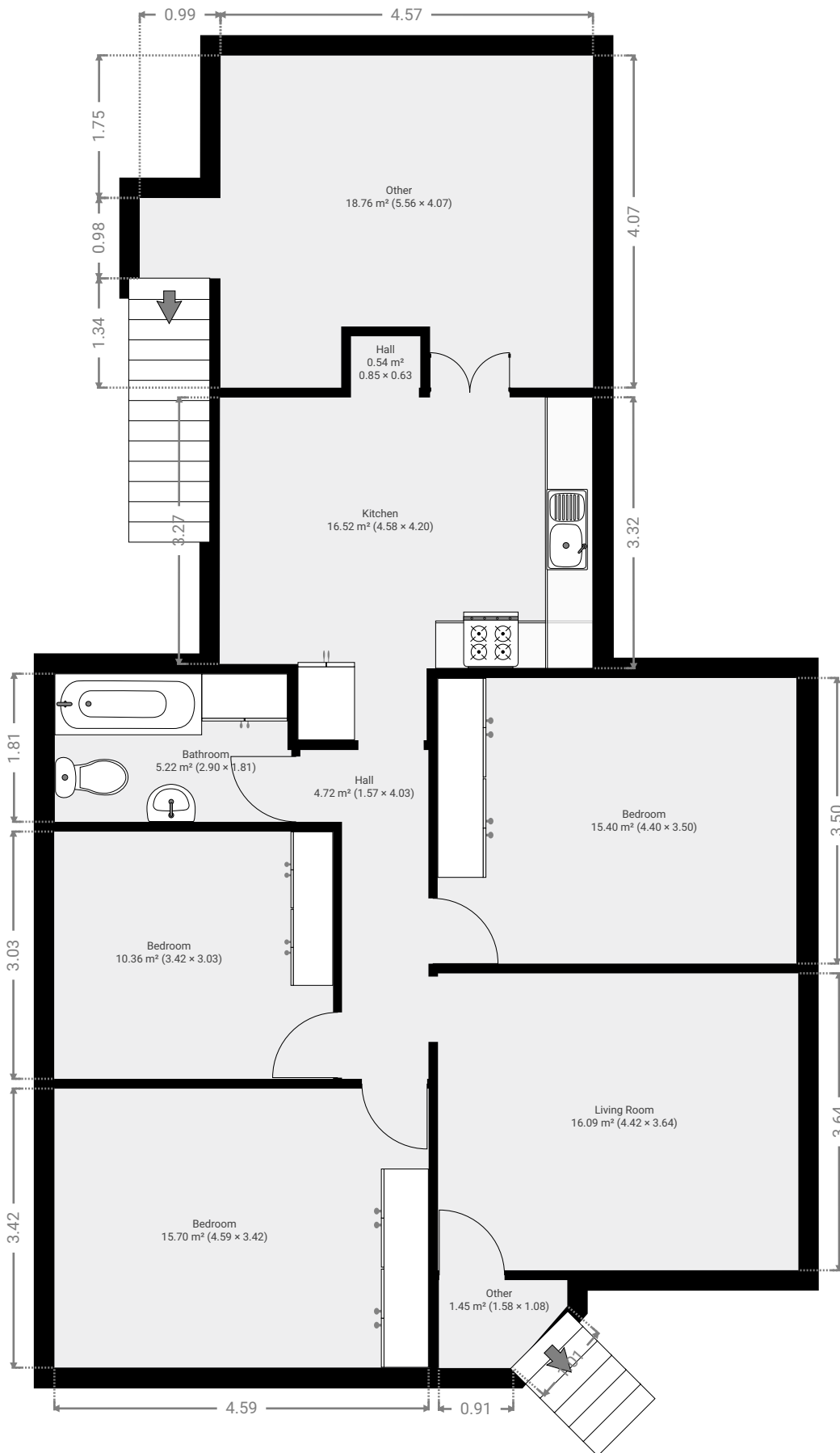

18 Bowen Terrace

FLOORS: 2



▼ Bathroom 1st Floor

WIDTH: 2.90 m • LENGTH: 1.81 m
AREA: 5.22 m² • PERIMETER: 9.43 m

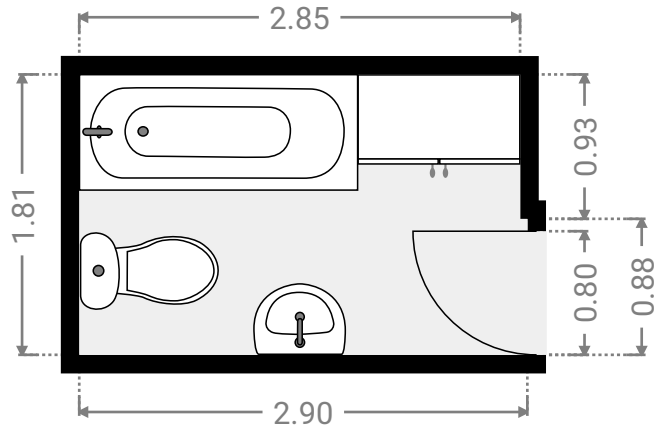
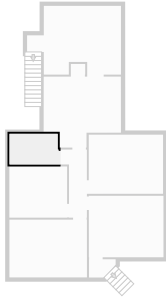

▼ Bedroom 1st Floor

WIDTH: 4.59 m • LENGTH: 3.42 m
AREA: 15.70 m² • PERIMETER: 16.02 m

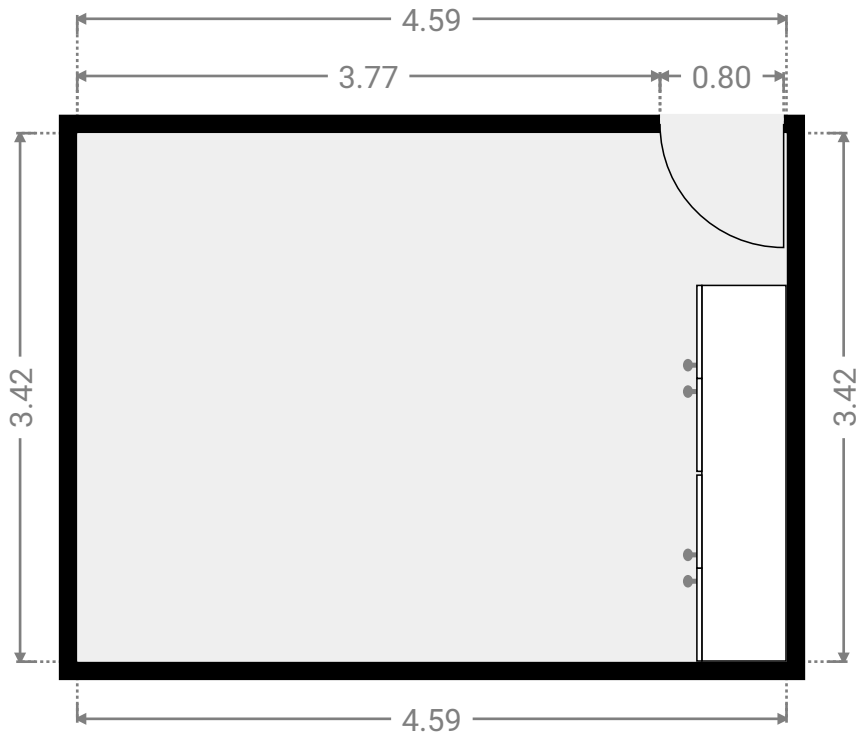
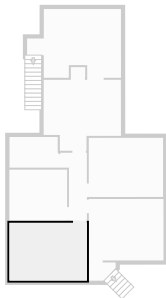

18 Bowen Terrace

FLOORS: 2



▼ Bedroom 1st Floor

WIDTH: 3.42 m • LENGTH: 3.03 m
AREA: 10.36 m² • PERIMETER: 12.90 m

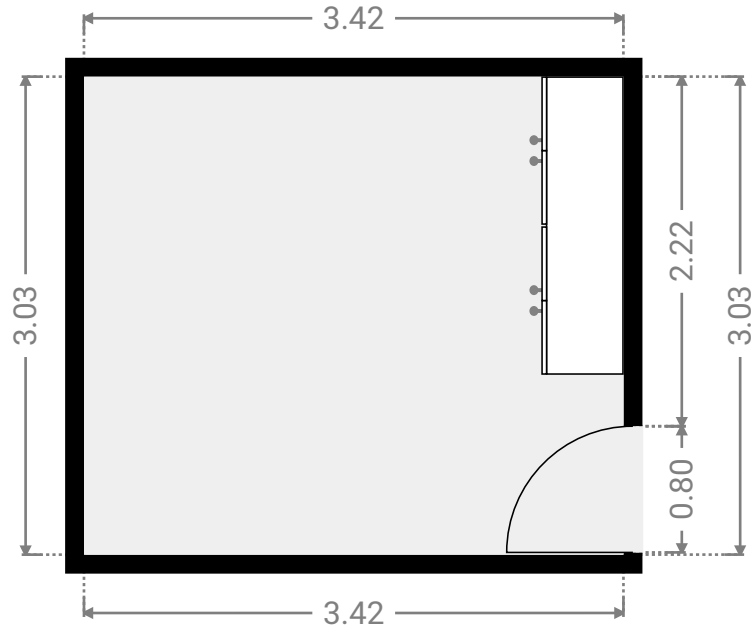
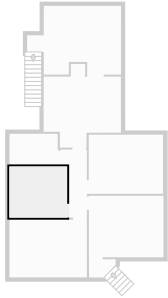

▼ Bedroom 1st Floor

WIDTH: 4.40 m • LENGTH: 3.50 m
AREA: 15.40 m² • PERIMETER: 15.80 m

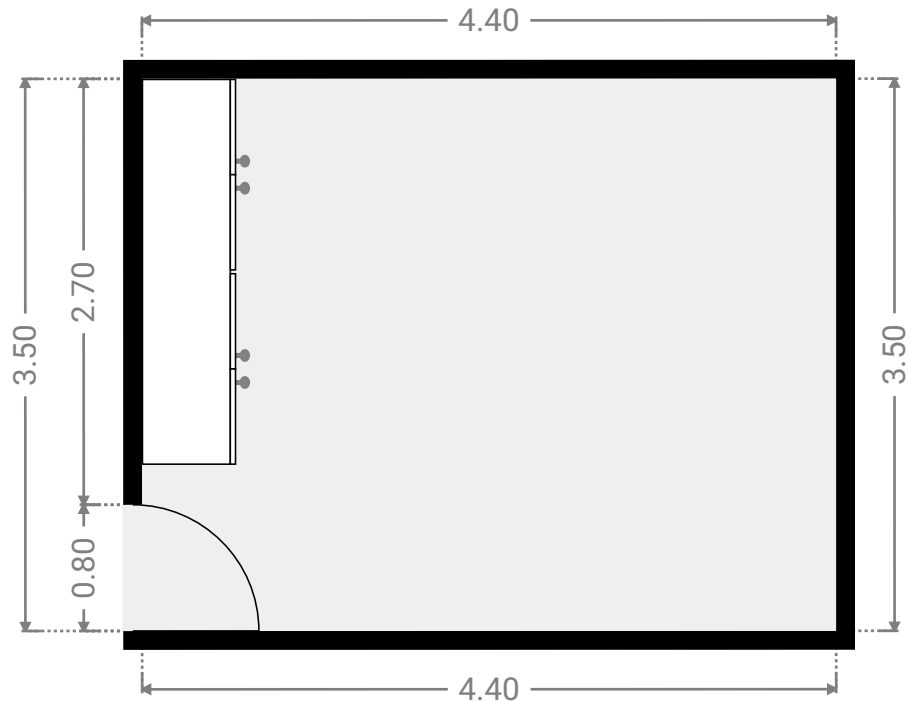
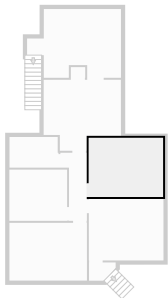

18 Bowen Terrace

FLOORS: 2



▼ Hall 1st Floor

WIDTH: 1.57 m • LENGTH: 4.03 m
AREA: 4.72 m² • PERIMETER: 11.20 m

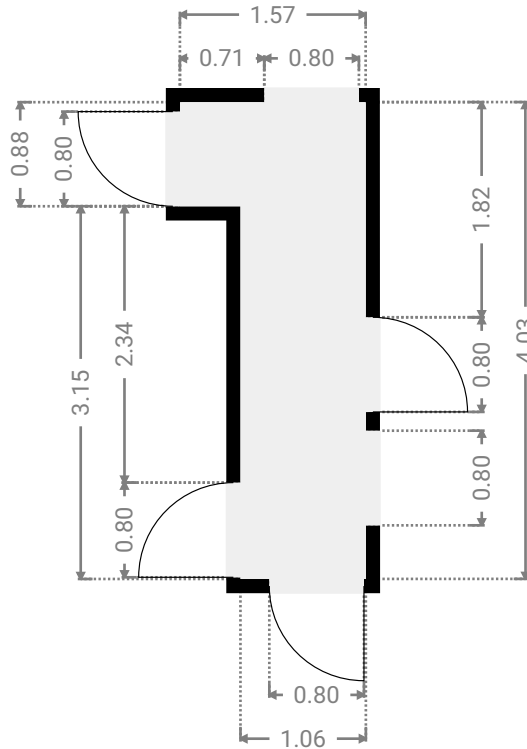
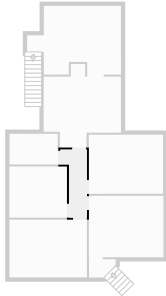

▼ Hall 1st Floor

WIDTH: 0.85 m • LENGTH: 0.63 m
AREA: 0.54 m² • PERIMETER: 2.96 m

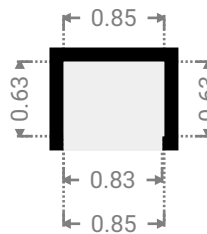
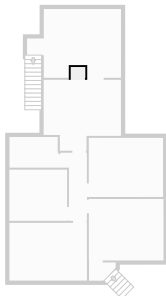

18 Bowen Terrace

FLOORS: 2



▼ Kitchen 1st Floor

WIDTH: 4.58 m • LENGTH: 4.20 m
AREA: 16.52 m² • PERIMETER: 17.55 m

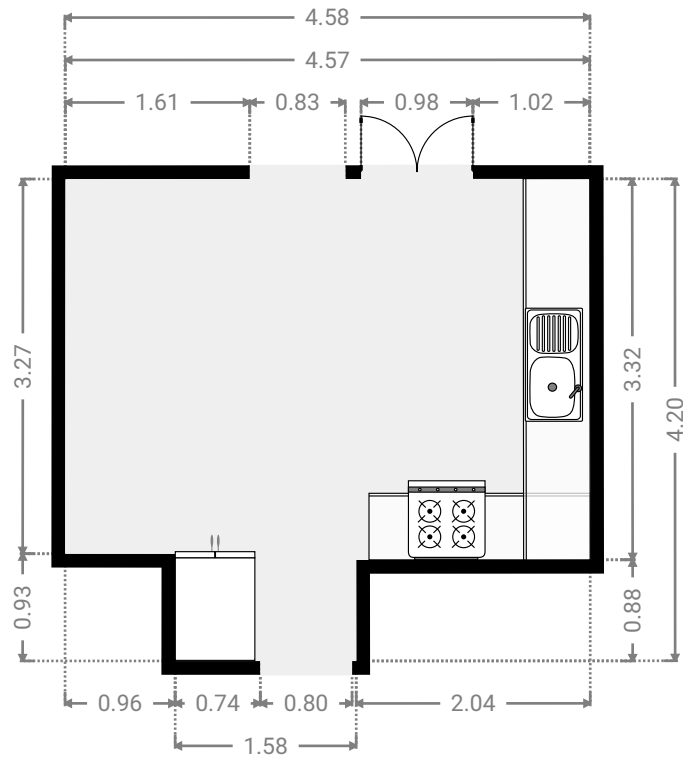
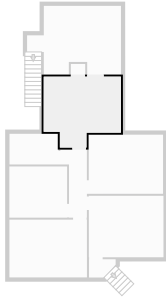

▼ Living Room 1st Floor

WIDTH: 4.42 m • LENGTH: 3.64 m
AREA: 16.09 m² • PERIMETER: 16.12 m

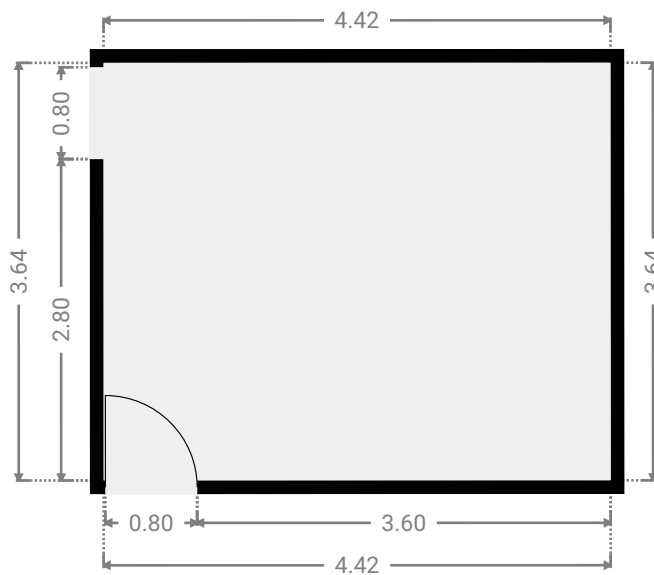
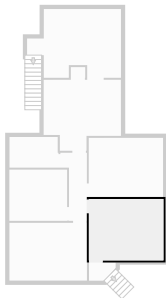

18 Bowen Terrace

FLOORS: 2



▼ Other 1st Floor

WIDTH: 1.58 m • LENGTH: 1.08 m
AREA: 1.45 m² • PERIMETER: 4.89 m

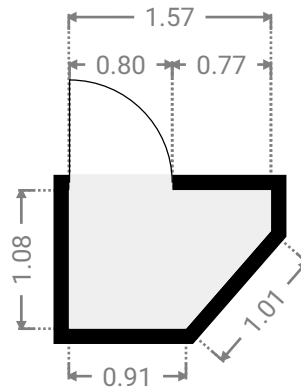
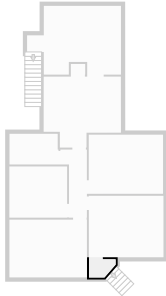

▼ Other 1st Floor

WIDTH: 5.56 m • LENGTH: 4.07 m
AREA: 18.76 m² • PERIMETER: 20.76 m

