

174 Peter Street

Created on
2021-01-19

Floors
2

▼ Ground Floor

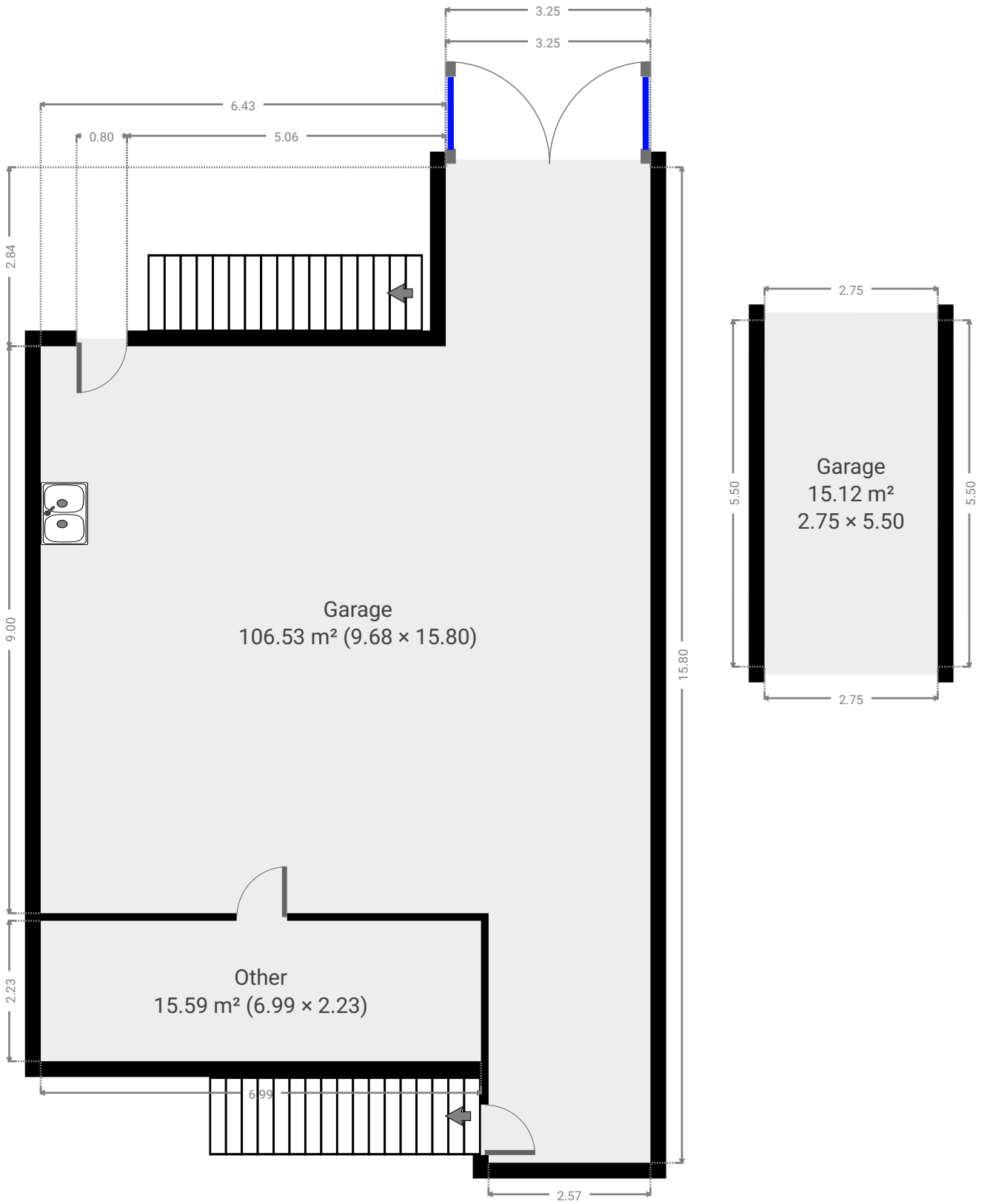

▼ Garage
Ground Floor

WIDTH:9.68 m · LENGTH:15.80 m
AREA:106.53 m² · PERIMETER:50.96 m

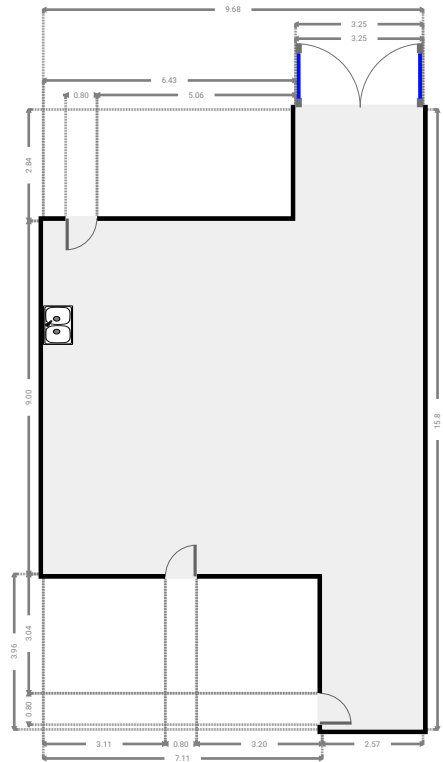
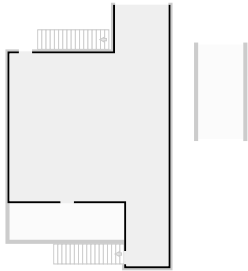

▼ Garage
Ground Floor

WIDTH:2.75 m · LENGTH:5.50 m
AREA:15.12 m² · PERIMETER:16.50 m

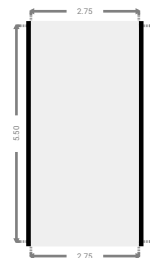
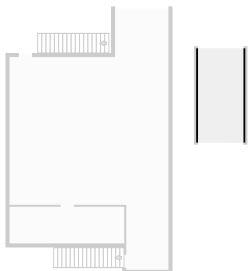

▼ Other
Ground Floor

WIDTH:6.99 m · LENGTH:2.23 m
AREA:15.59 m² · PERIMETER:18.44 m

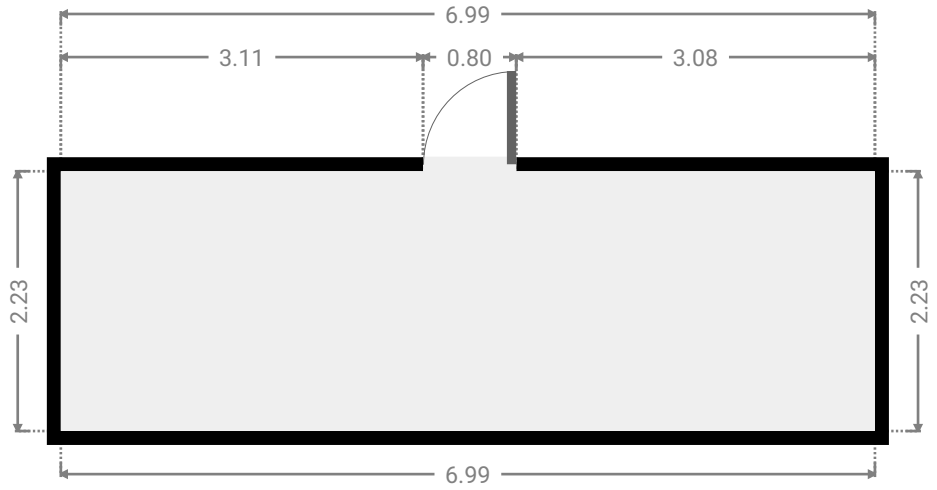
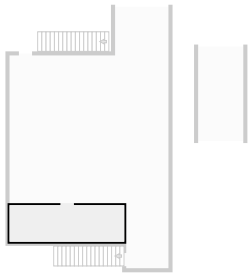

▼ 1st Floor

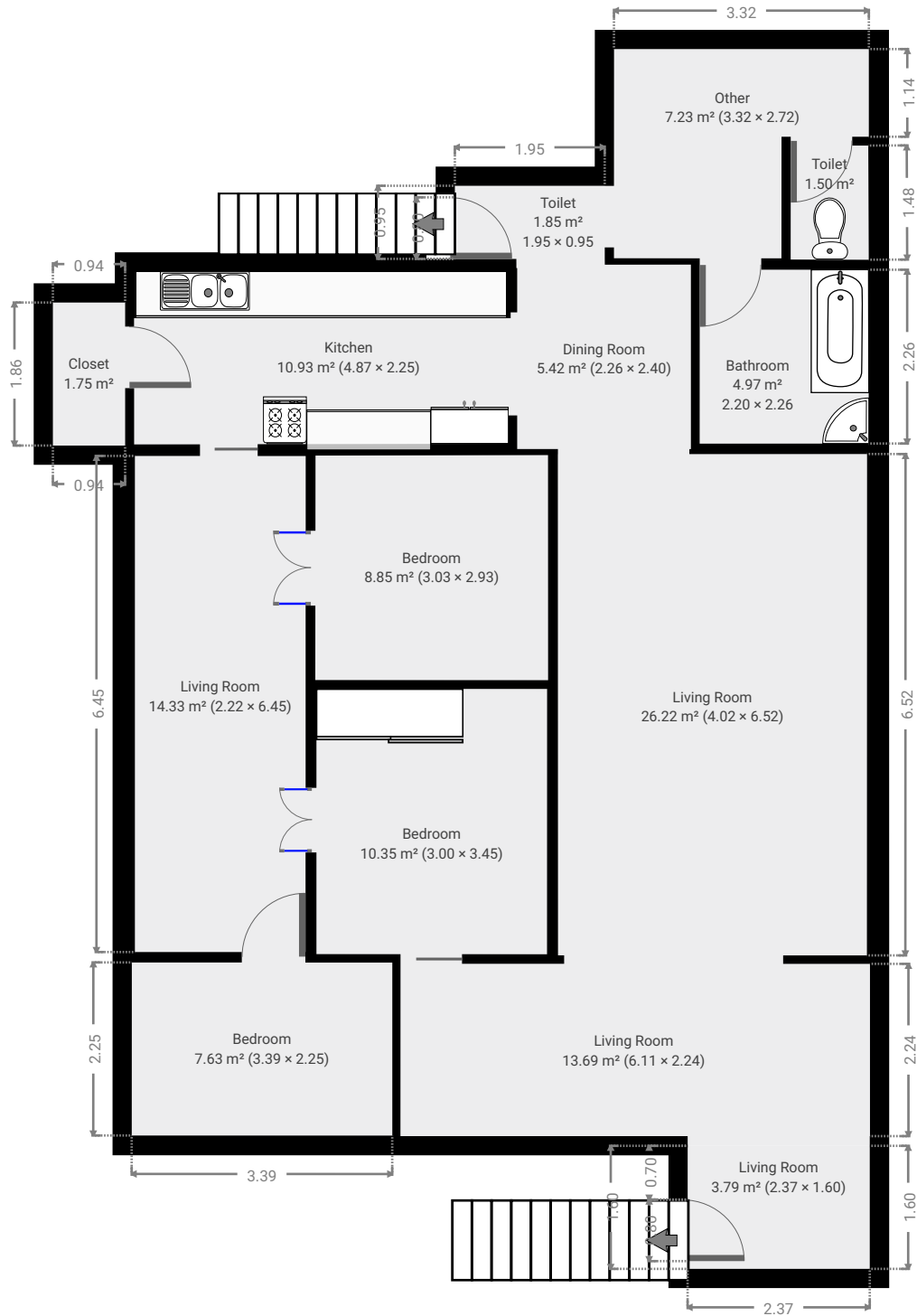

▼ Living Room
1st Floor

WIDTH:2.37 m · LENGTH:1.60 m
AREA:3.79 m² · PERIMETER:7.94 m

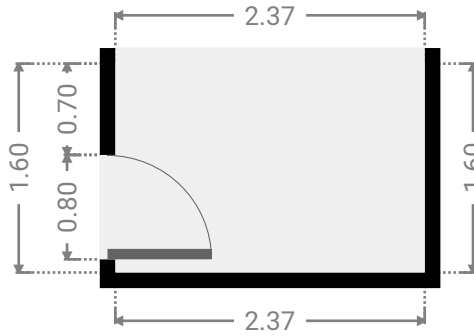
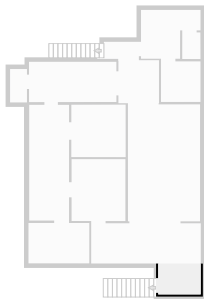

▼ Living Room
1st Floor

WIDTH:6.11 m · LENGTH:2.24 m
AREA:13.69 m² · PERIMETER:16.70 m

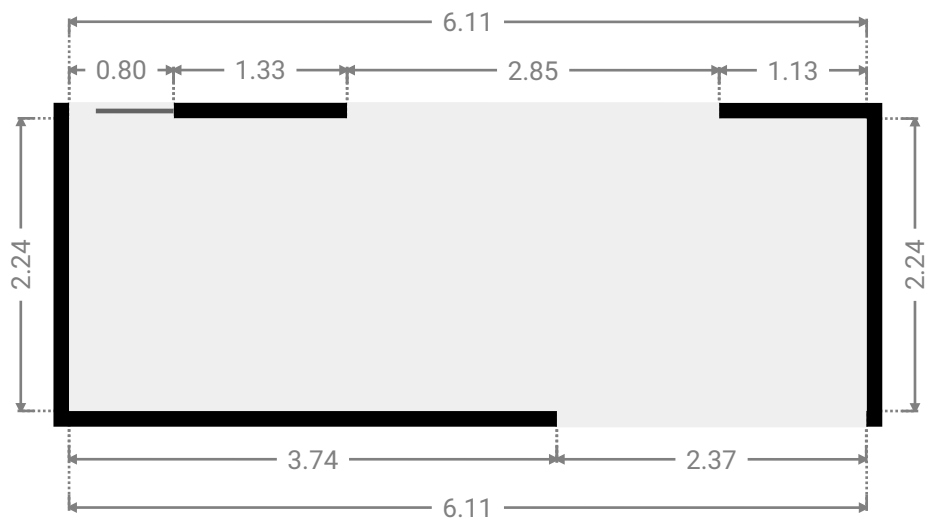
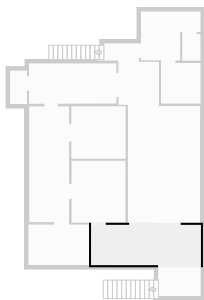

▼ **Living Room**
1st Floor

WIDTH:4.02 m · LENGTH:6.52 m
AREA:26.22 m² · PERIMETER:21.08 m

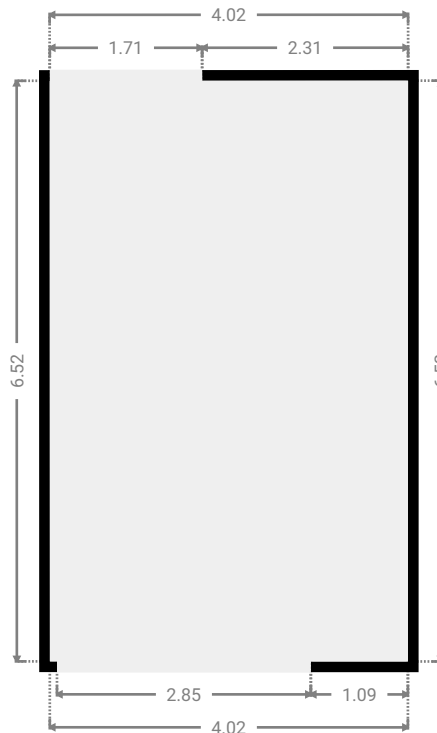
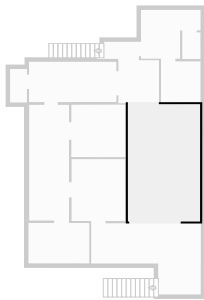

▼ **Dining Room**
1st Floor

WIDTH:2.26 m · LENGTH:2.40 m
AREA:5.42 m² · PERIMETER:9.32 m

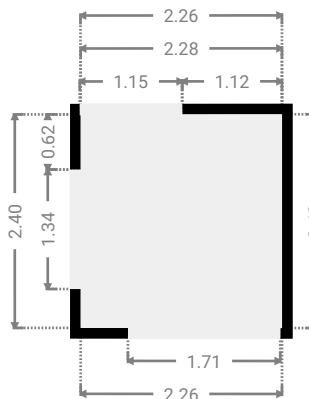
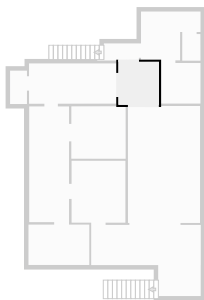

▼ **Kitchen**
1st Floor

WIDTH:4.87 m · LENGTH:2.25 m
AREA:10.93 m² · PERIMETER:14.23 m

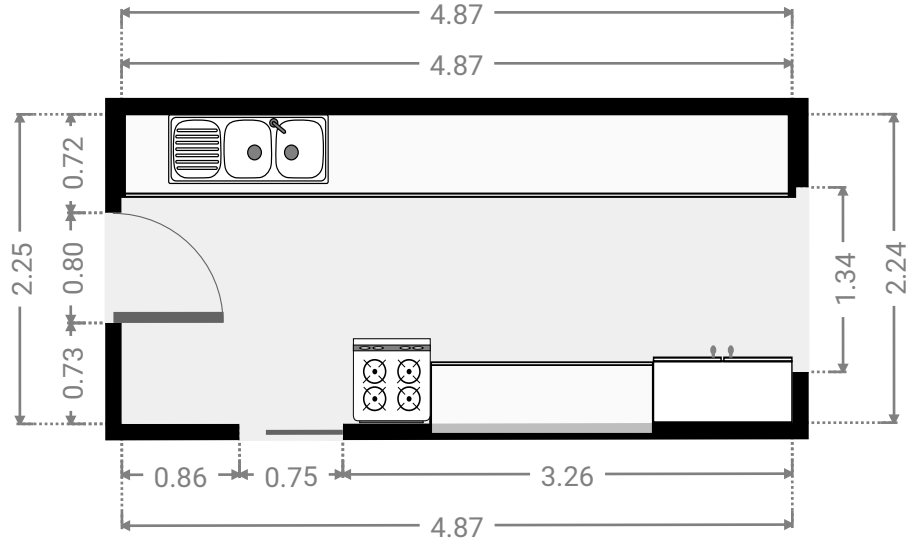
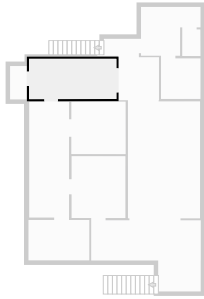

▼ **Closet**
1st Floor

WIDTH:0.94 m · LENGTH:1.86 m
AREA:1.75 m² · PERIMETER:5.60 m

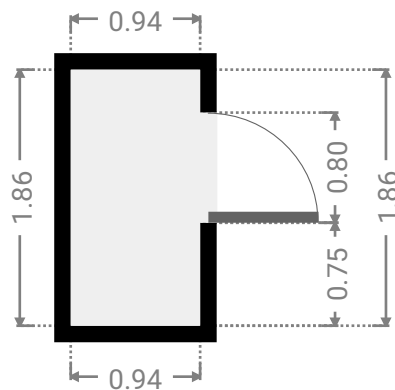
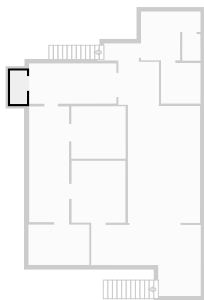

▼ **Bedroom**
1st Floor

WIDTH:3.39 m · LENGTH:2.25 m
AREA:7.63 m² · PERIMETER:11.28 m

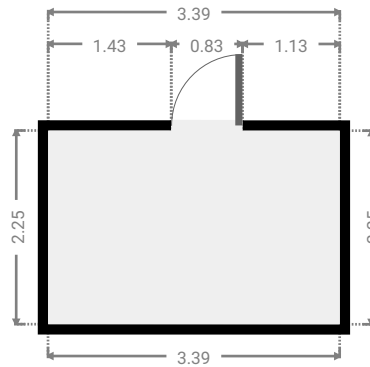
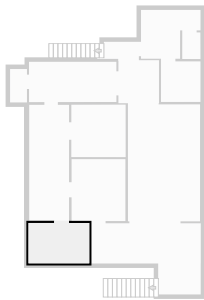

▼ **Living Room**
1st Floor

WIDTH:2.22 m · LENGTH:6.45 m
AREA:14.33 m² · PERIMETER:17.34 m

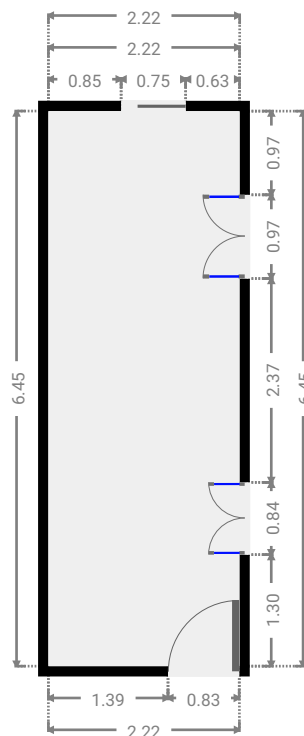
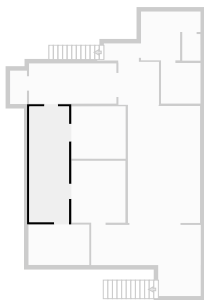

▼ Bedroom
1st Floor

WIDTH:3.00 m · LENGTH:3.45 m
AREA:10.35 m² · PERIMETER:12.90 m

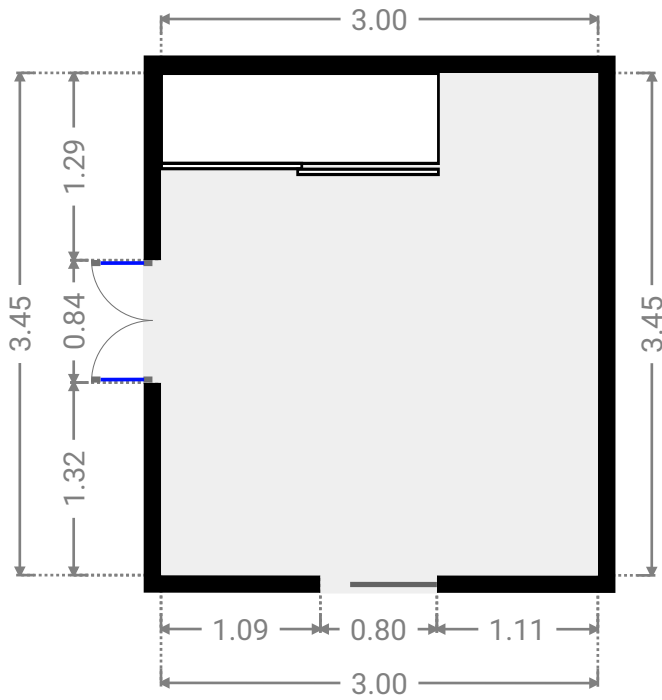
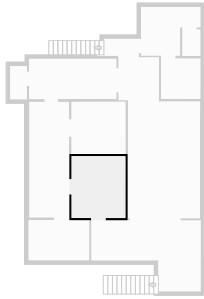

▼ Bedroom
1st Floor

WIDTH:3.03 m · LENGTH:2.93 m
AREA:8.85 m² · PERIMETER:11.90 m

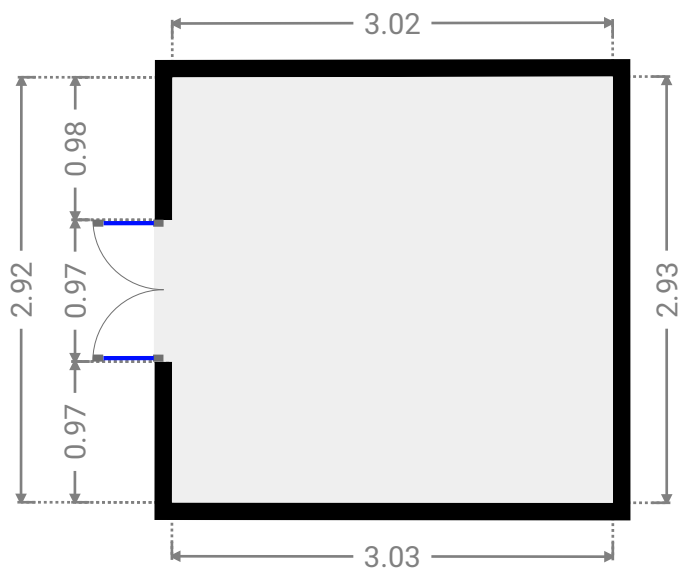
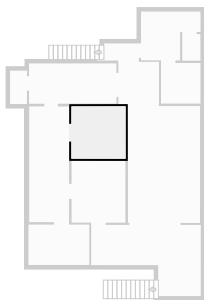

▼ **Toilet**
1st Floor

WIDTH:1.95 m · LENGTH:0.95 m
AREA:1.85 m² · PERIMETER:5.80 m

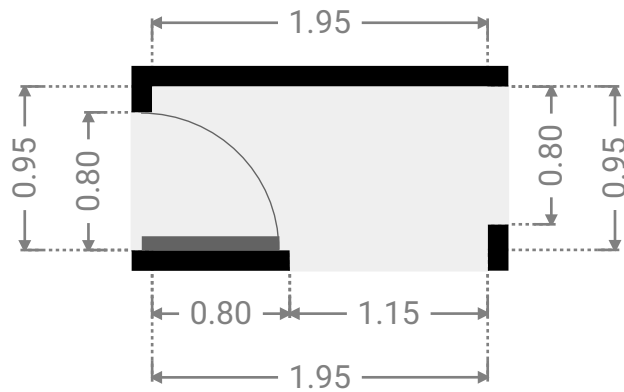
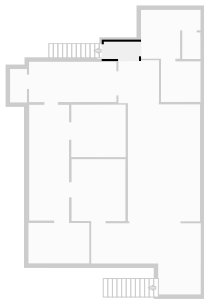

▼ **Bathroom**
1st Floor

WIDTH:2.20 m · LENGTH:2.26 m
AREA:4.97 m² · PERIMETER:8.92 m

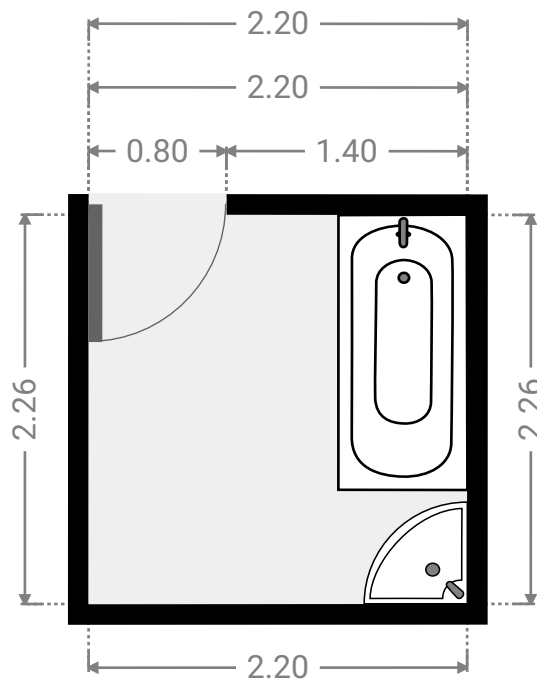
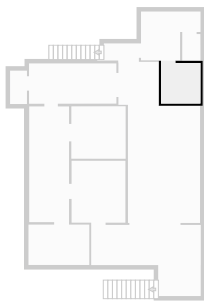

▼ **Other**
1st Floor

WIDTH:3.32 m · LENGTH:2.72 m
AREA:7.23 m² · PERIMETER:12.07 m

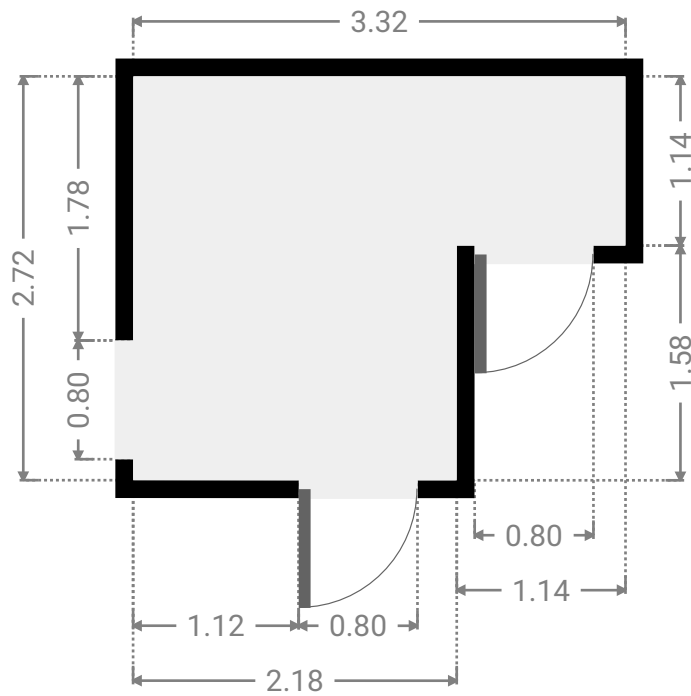
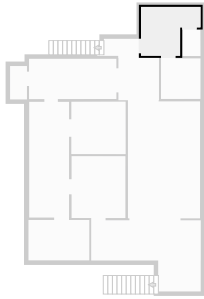

▼ **Toilet**
1st Floor

WIDTH:1.02 m · LENGTH:1.49 m
AREA:1.50 m² · PERIMETER:4.99 m

