

17 Toonda Street Bajool

SUBMITTED BY

Ray White Rockhampton Casey
stockers@cqoz.com

CREATED ON

2019-04-04

Floors

1

▼ Ground Floor

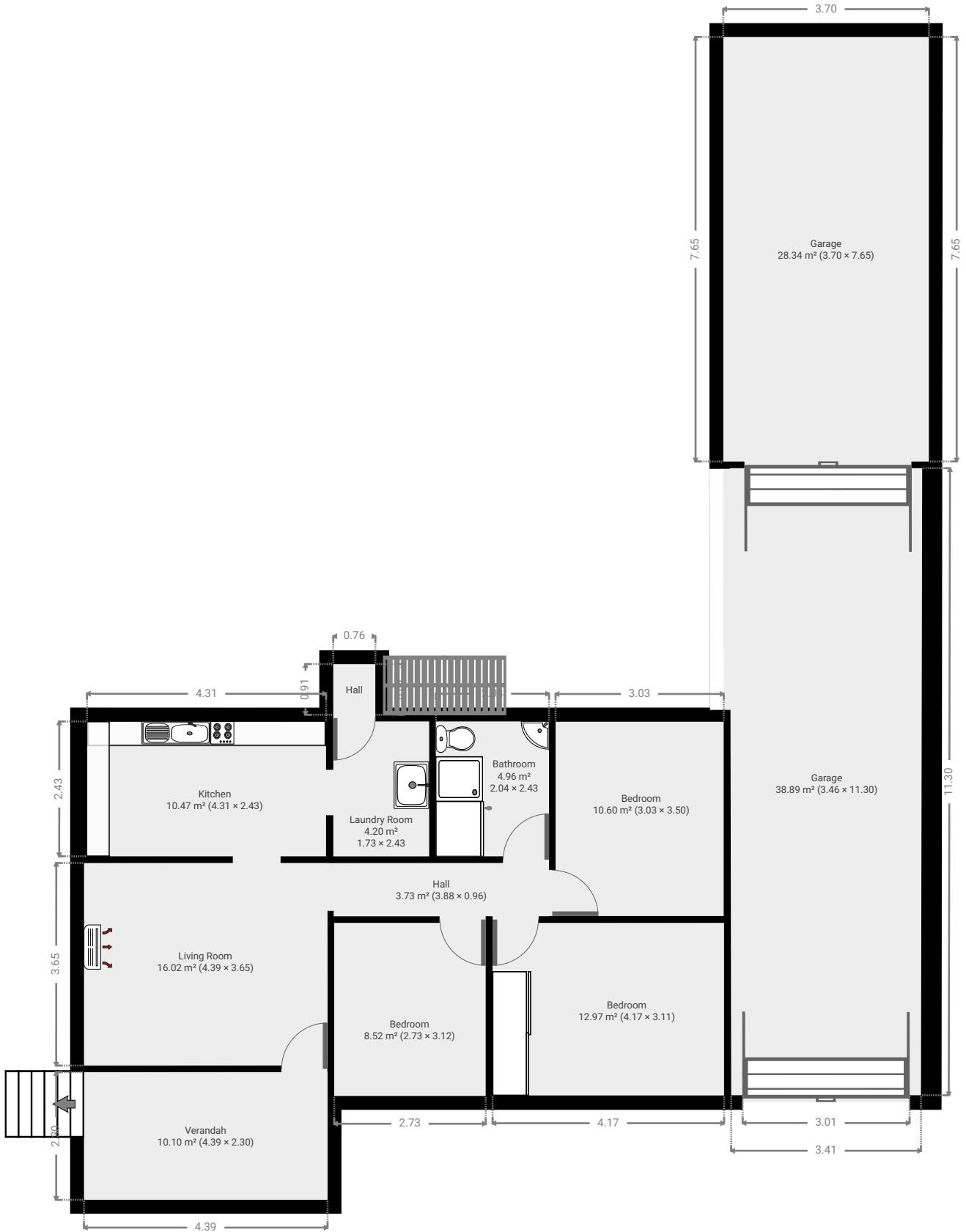

FLOORS: 1

▼ Living Room Ground Floor

WIDTH: 4.39 m • LENGTH: 3.65 m
AREA: 16.02 m² • PERIMETER: 16.08 m

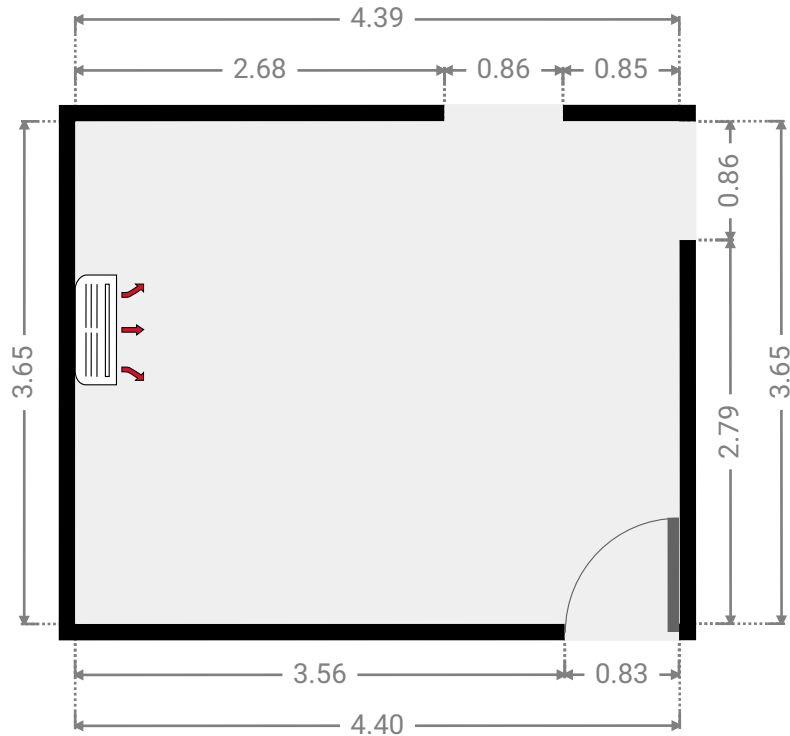
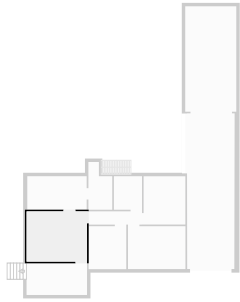

▼ Kitchen Ground Floor

WIDTH: 4.31 m • LENGTH: 2.43 m
AREA: 10.47 m² • PERIMETER: 13.48 m

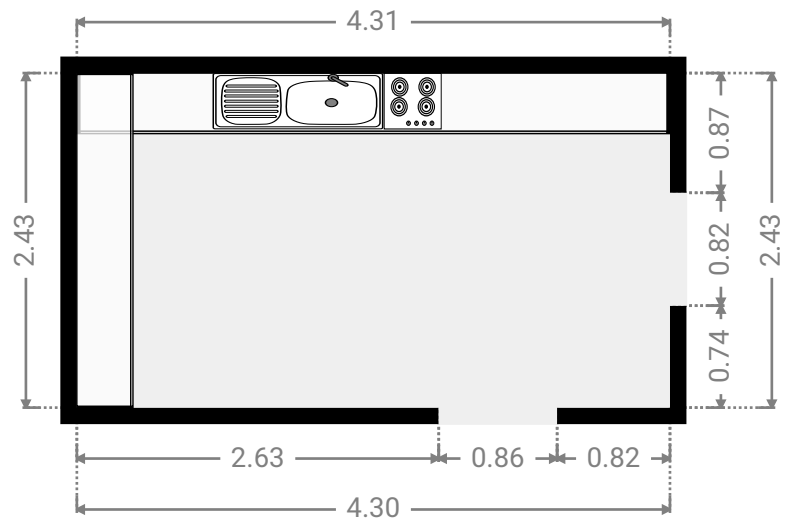
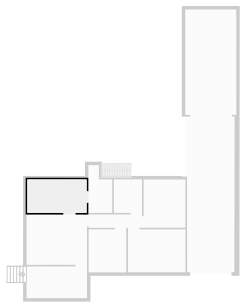

FLOORS: 1

▼ Hall Ground Floor

WIDTH: 3.88 m • LENGTH: 0.96 m
AREA: 3.73 m² • PERIMETER: 9.68 m

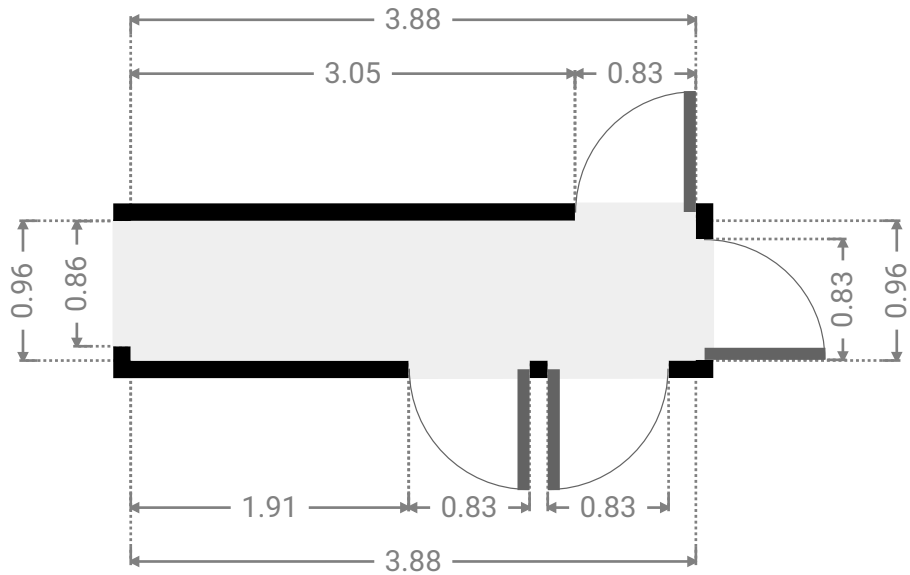
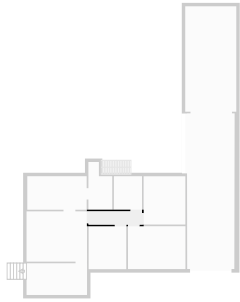

▼ Bedroom Ground Floor

WIDTH: 2.73 m • LENGTH: 3.12 m
AREA: 8.52 m² • PERIMETER: 11.70 m

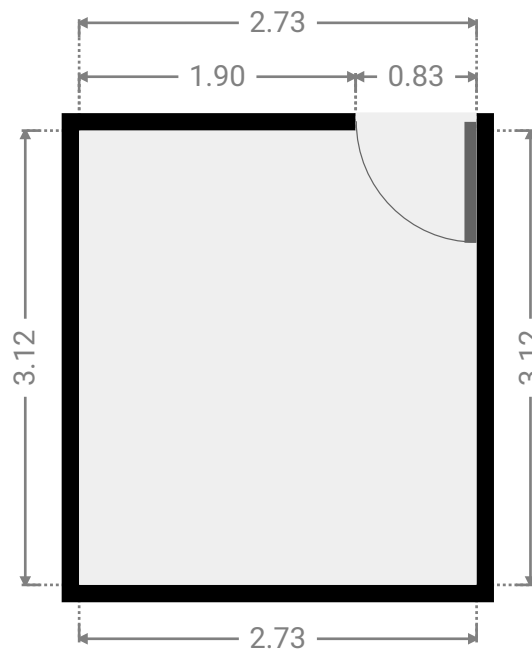
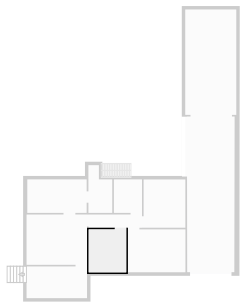

FLOORS: 1

▼ Bedroom Ground Floor

WIDTH: 4.17 m • LENGTH: 3.11 m
AREA: 12.97 m² • PERIMETER: 14.56 m

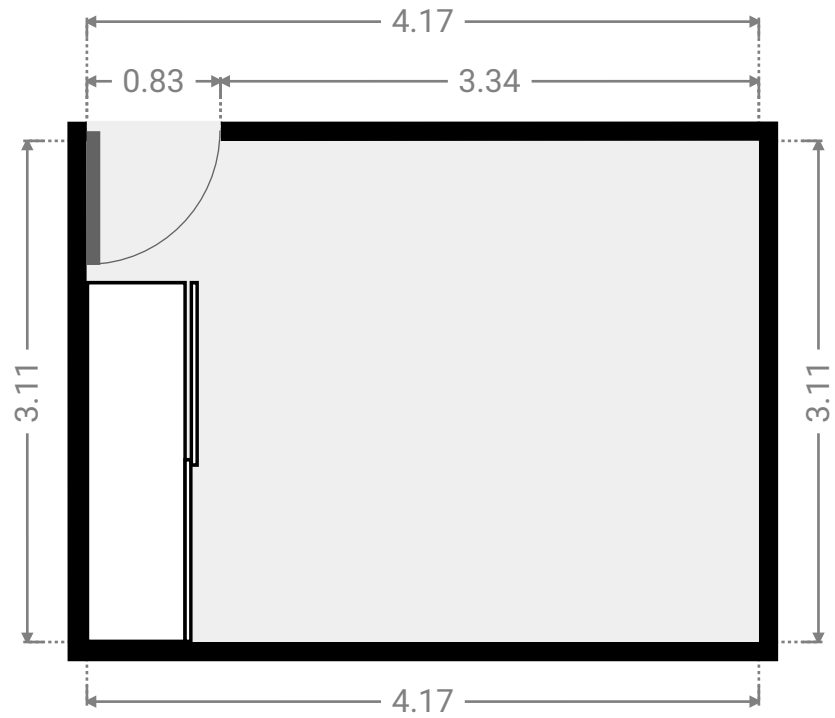
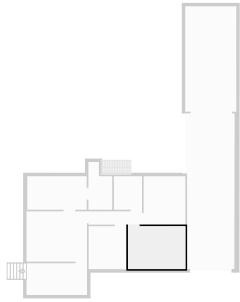

▼ Bedroom Ground Floor

WIDTH: 3.03 m • LENGTH: 3.50 m
AREA: 10.60 m² • PERIMETER: 13.06 m

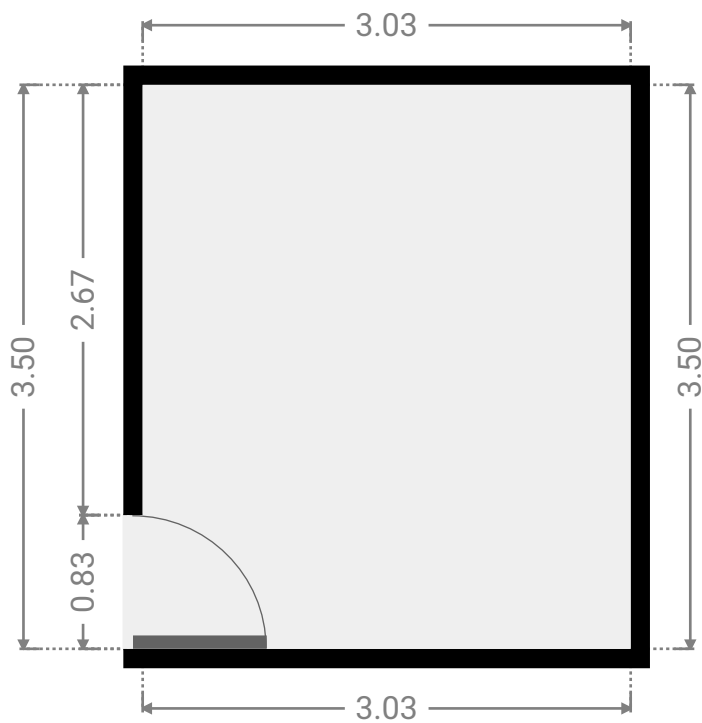

FLOORS: 1

▼ Bathroom
Ground Floor

WIDTH: 2.04 m • LENGTH: 2.43 m
AREA: 4.96 m² • PERIMETER: 8.94 m

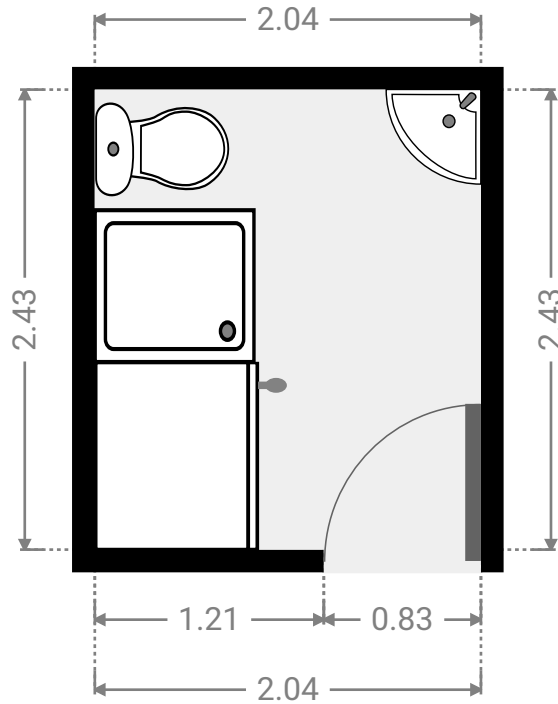
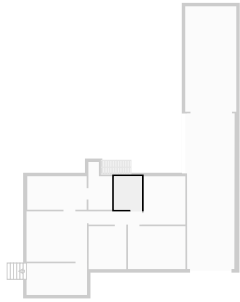

▼ Laundry Room
Ground Floor

WIDTH: 1.73 m • LENGTH: 2.43 m
AREA: 4.20 m² • PERIMETER: 8.32 m

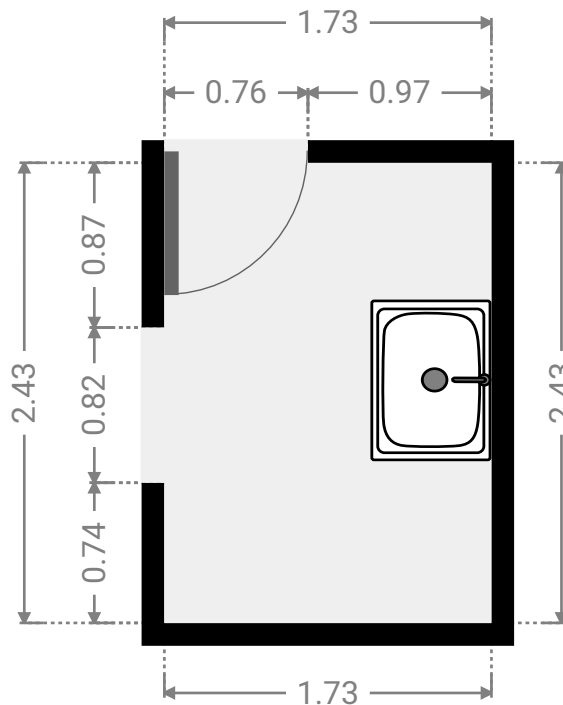
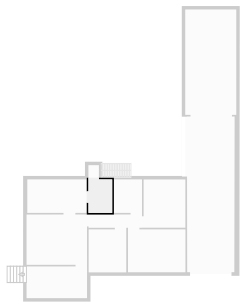

FLOORS: 1

▼ Hall Ground Floor

WIDTH: 0.76 m • LENGTH: 0.91 m
AREA: 0.69 m² • PERIMETER: 3.34 m

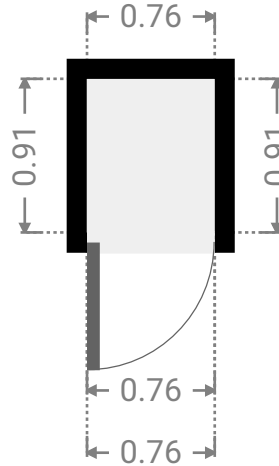
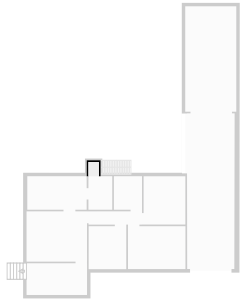

▼ Verandah Ground Floor

WIDTH: 4.39 m • LENGTH: 2.30 m
AREA: 10.10 m² • PERIMETER: 13.38 m

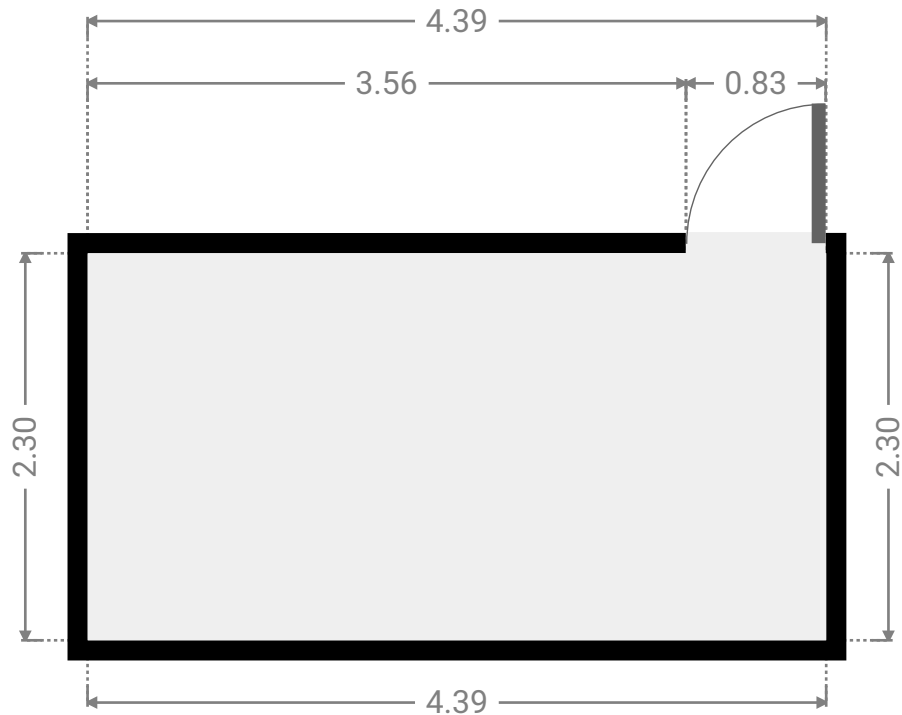

FLOORS: 1

▼ Garage Ground Floor

WIDTH: 3.46 m • LENGTH: 11.30 m
AREA: 38.89 m² • PERIMETER: 29.48 m

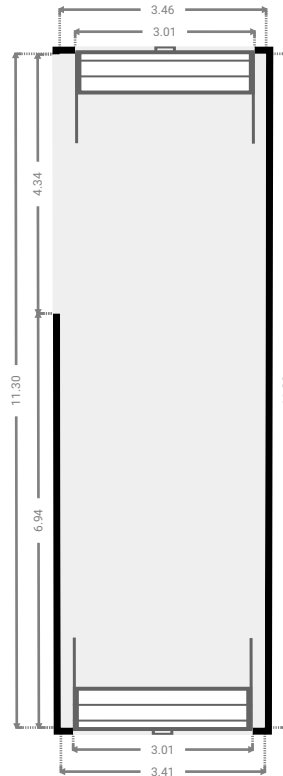
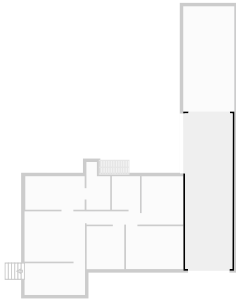

▼ Garage Ground Floor

WIDTH: 3.70 m • LENGTH: 7.65 m
AREA: 28.34 m² • PERIMETER: 22.71 m

