

17 O'Sullivan Street

SUBMITTED BY

Ray White Rockhampton Casey
stockers@cqoz.com

CREATED ON

2021-11-23

Floors

1

▼ Ground Floor

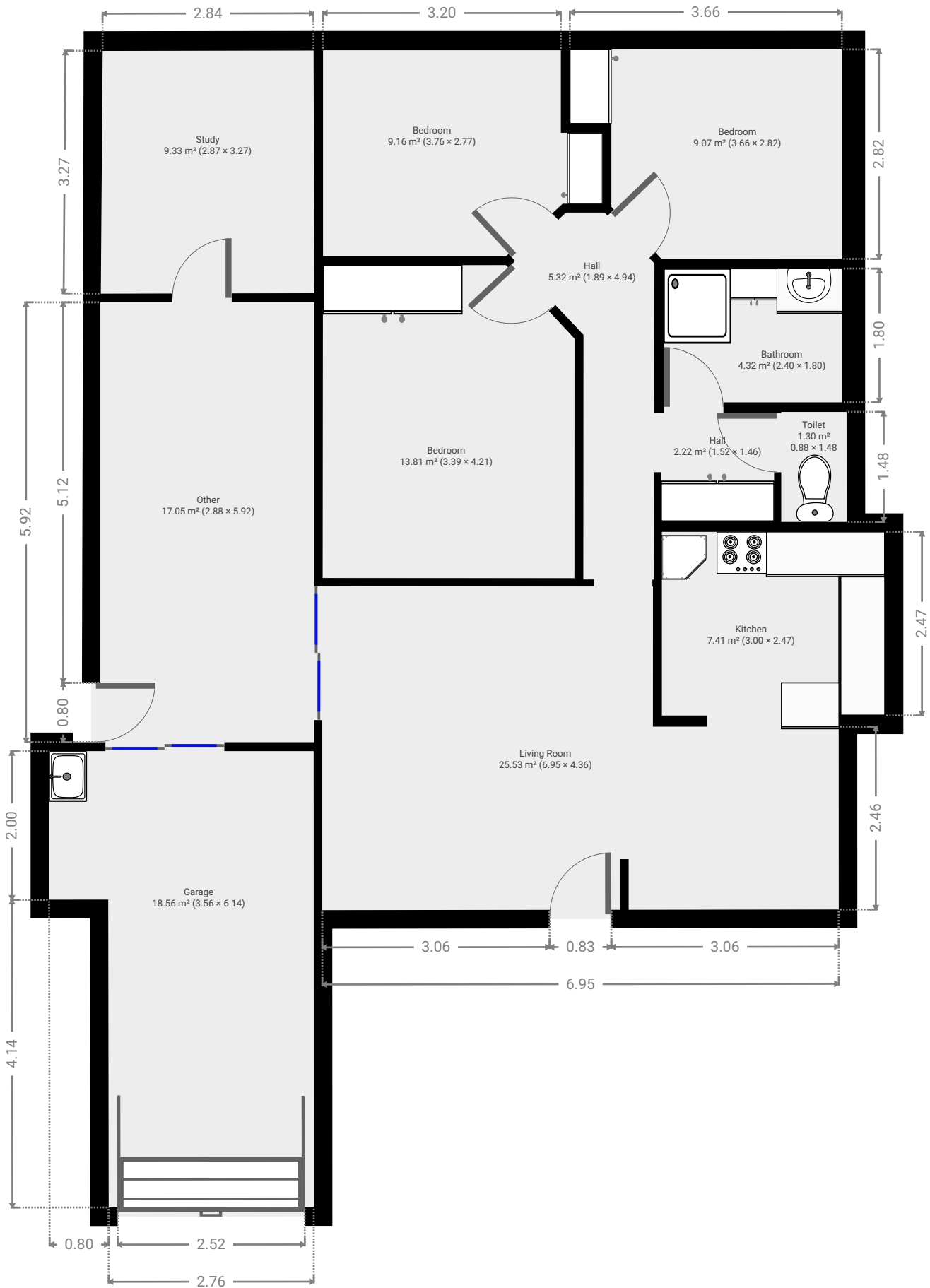

▼ **Living Room**
Ground Floor

WIDTH: 6.95 m • LENGTH: 4.36 m
AREA: 25.53 m² • PERIMETER: 22.61 m

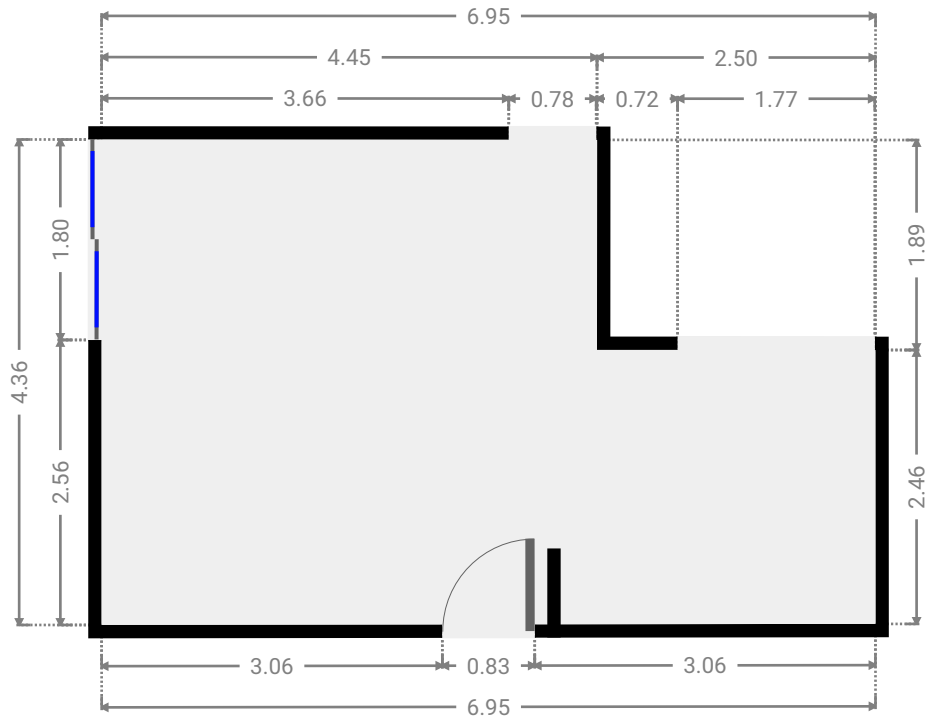
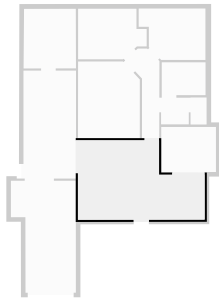

▼ **Kitchen**
Ground Floor

WIDTH: 3.00 m • LENGTH: 2.47 m
AREA: 7.41 m² • PERIMETER: 10.94 m

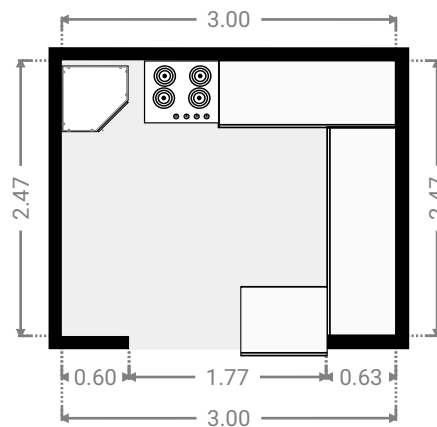
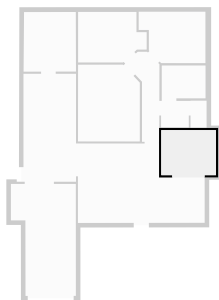

▼ **Hall**
Ground Floor

WIDTH: 1.89 m • LENGTH: 4.94 m
AREA: 5.32 m² • PERIMETER: 12.29 m

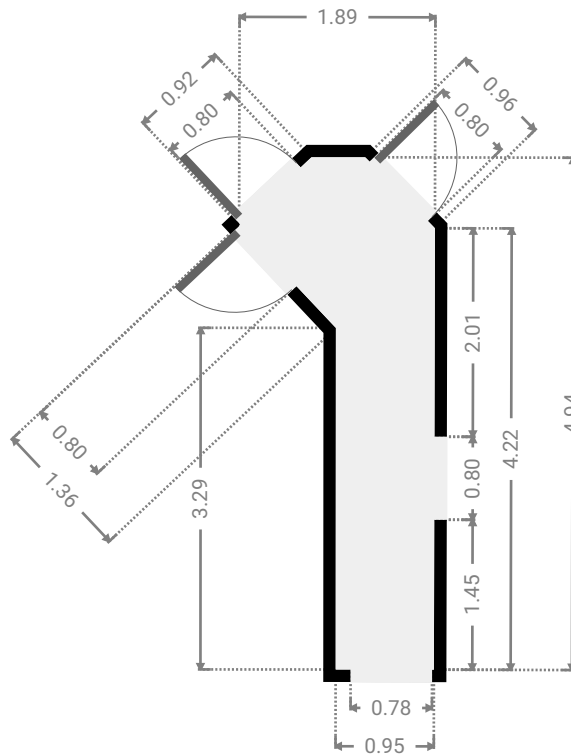
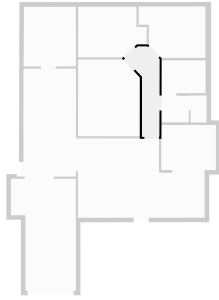

▼ **Hall**
Ground Floor

WIDTH: 1.52 m • LENGTH: 1.46 m
AREA: 2.22 m² • PERIMETER: 5.96 m

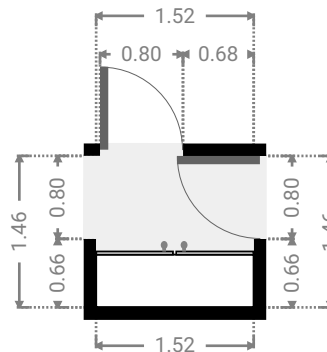
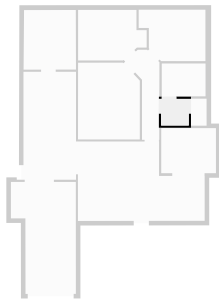

▼ **Toilet**
Ground Floor

WIDTH: 0.88 m • LENGTH: 1.48 m
AREA: 1.30 m² • PERIMETER: 4.72 m

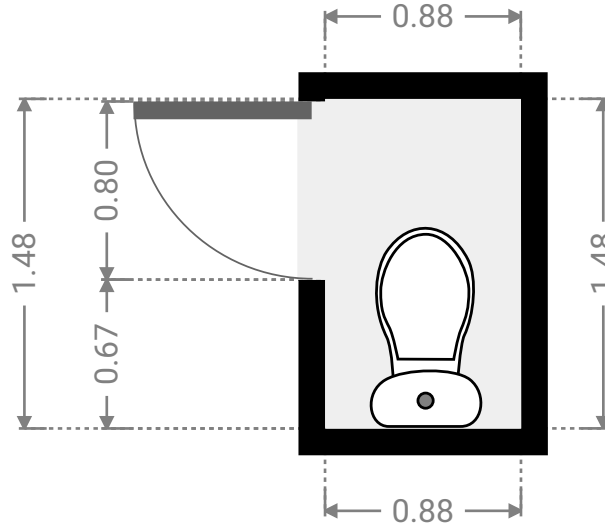
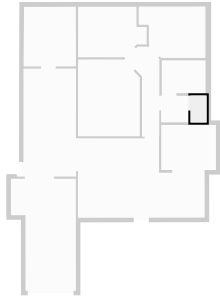

▼ **Bathroom**
Ground Floor

WIDTH: 2.40 m • LENGTH: 1.80 m
AREA: 4.32 m² • PERIMETER: 8.40 m

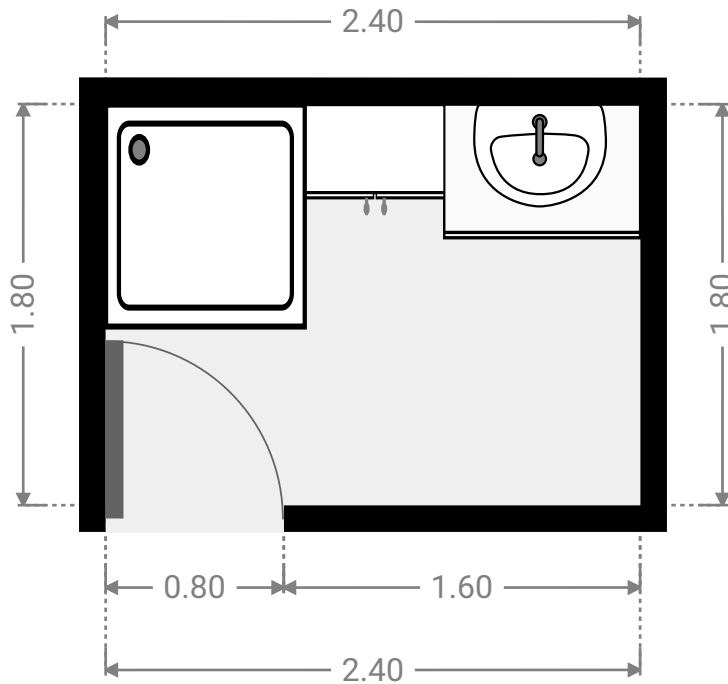
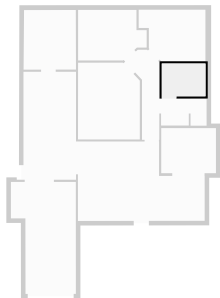

▼ **Bedroom**
Ground Floor

WIDTH: 3.66 m • LENGTH: 2.82 m
AREA: 9.07 m² • PERIMETER: 12.56 m

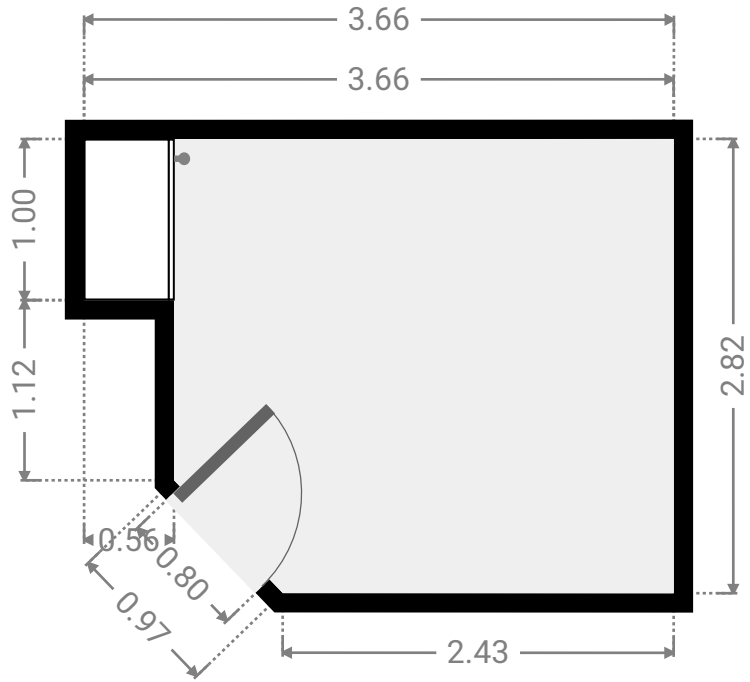
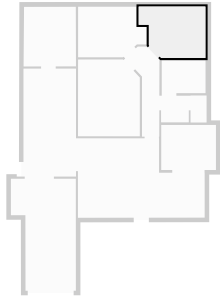

▼ **Bedroom**
Ground Floor

WIDTH: 3.76 m • LENGTH: 2.77 m
AREA: 9.16 m² • PERIMETER: 12.64 m

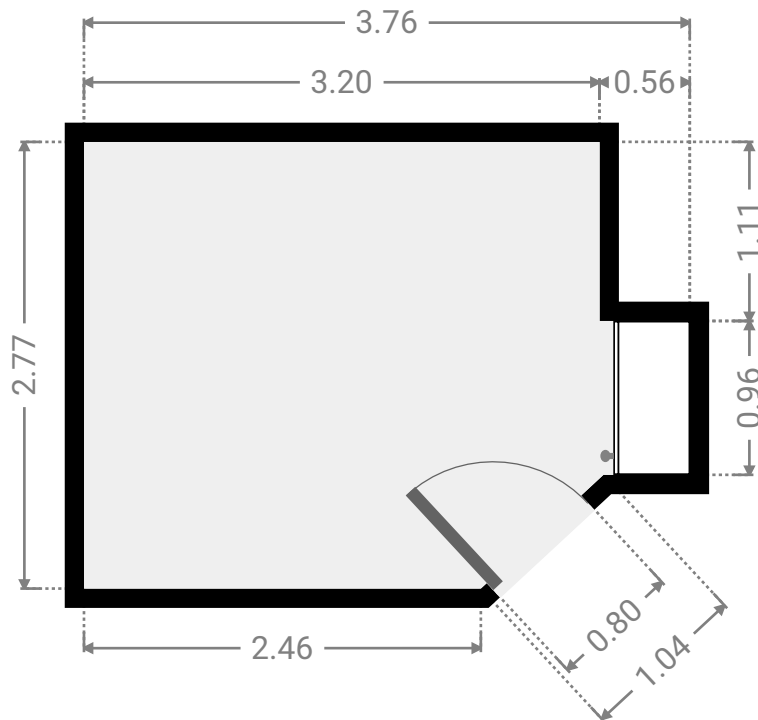
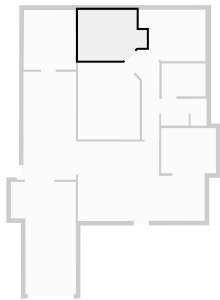

▼ **Bedroom**
Ground Floor

WIDTH: 3.39 m • LENGTH: 4.21 m
AREA: 13.81 m² • PERIMETER: 14.64 m

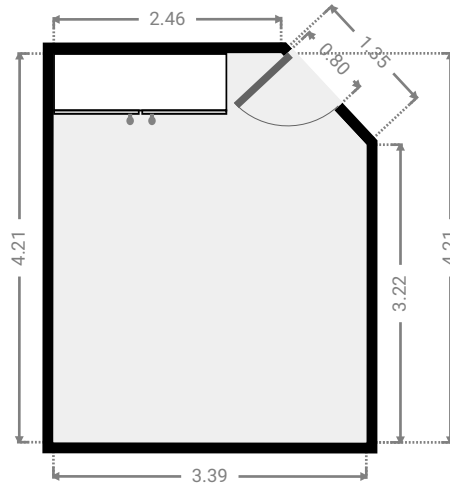
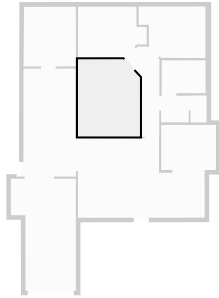

▼ **Other**
Ground Floor

WIDTH: 2.88 m • LENGTH: 5.92 m
AREA: 17.05 m² • PERIMETER: 17.60 m

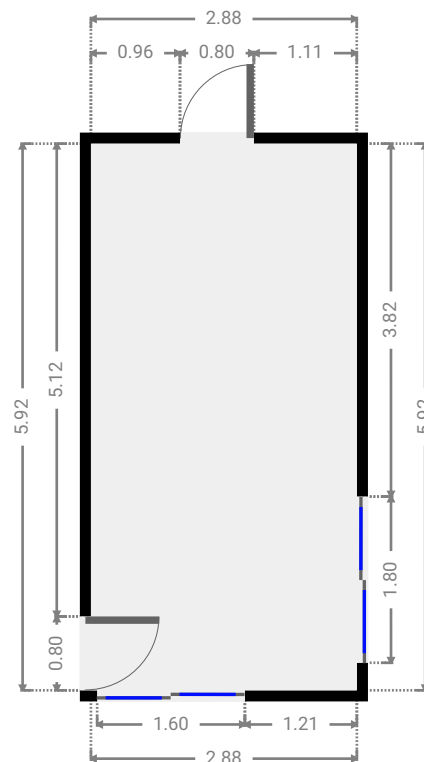
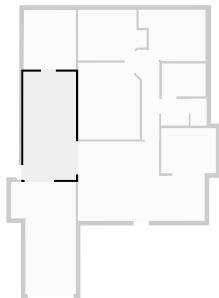

FLOORS: 1

▼ **Garage**
Ground Floor

WIDTH: 3.56 m • LENGTH: 6.14 m
AREA: 18.56 m² • PERIMETER: 19.40 m

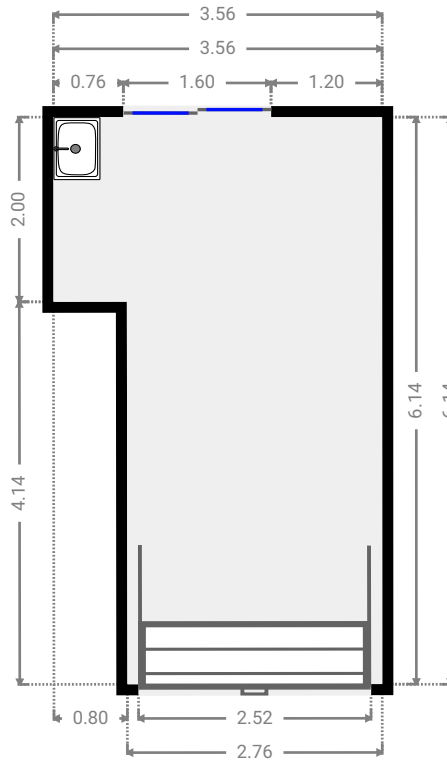
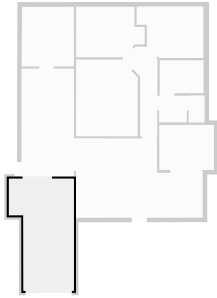

▼ **Study**
Ground Floor

WIDTH: 2.87 m • LENGTH: 3.27 m
AREA: 9.33 m² • PERIMETER: 12.24 m

