

17 Labanka Crescent

Ground Floor

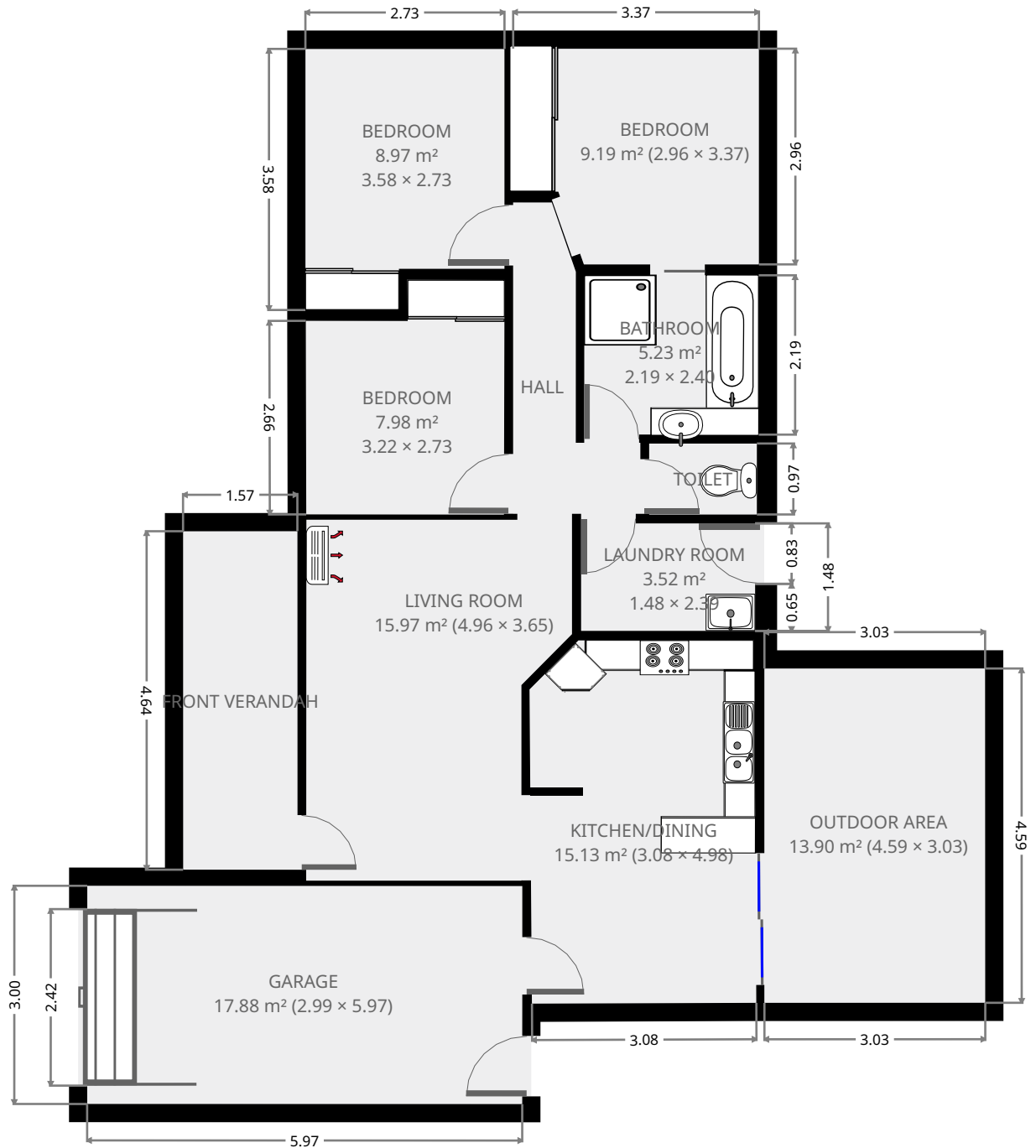

THIS FLOORPLAN IS PROVIDED WITHOUT WARRANTY OF ANY KIND. SENSOPIA DISCLAIMS ANY WARRANTY INCLUDING, WITHOUT LIMITATION, SATISFACTORY QUALITY OR ACCURACY OF DIMENSIONS.

17 Labanka Crescent

Living Room

Width: 3.65 m
 Length: 4.96 m
 Area: 15.97 m²
 Perimeter: 16.80 m

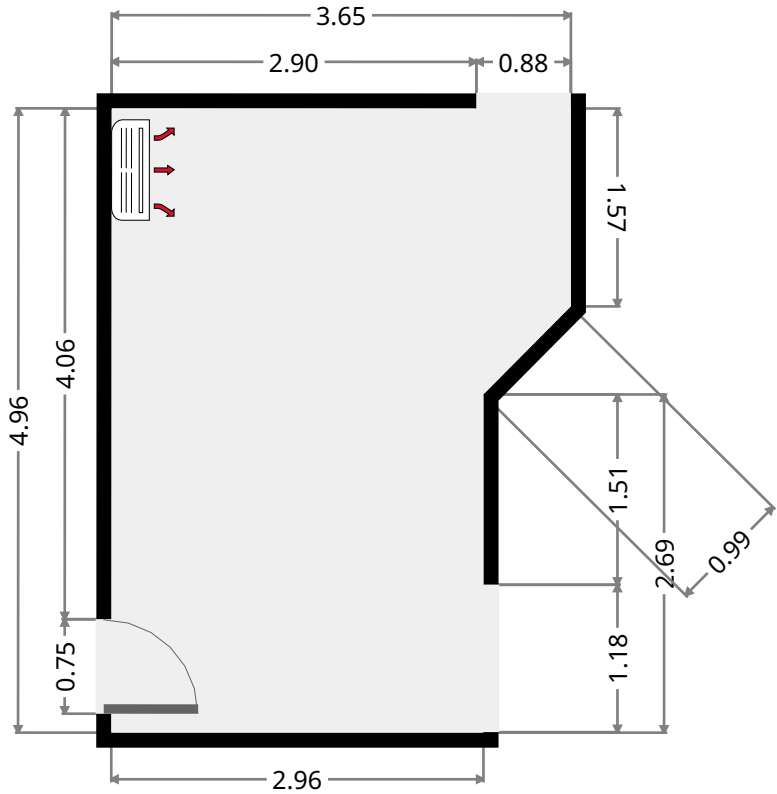
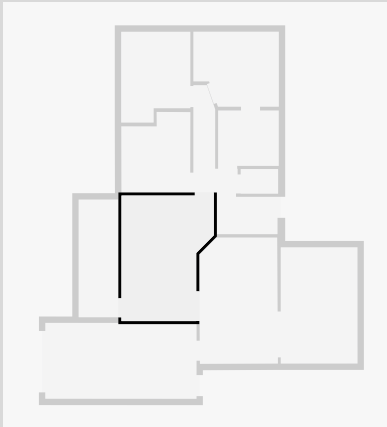

Kitchen/Dining

Width: 3.08 m
 Length: 4.98 m
 Area: 15.13 m²
 Perimeter: 15.73 m

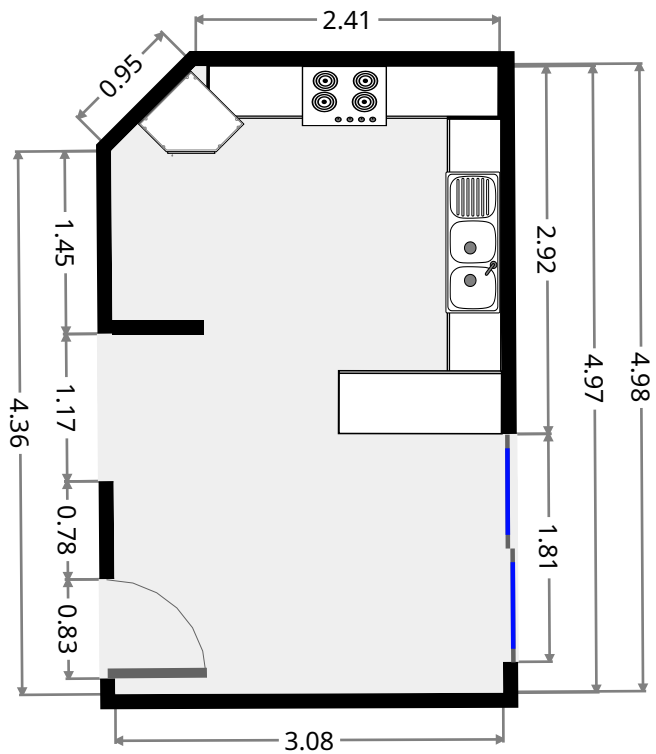
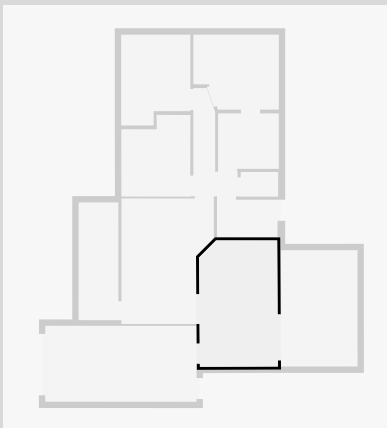

THIS FLOORPLAN IS PROVIDED WITHOUT WARRANTY OF ANY KIND. SENSOPIA DISCLAIMS ANY WARRANTY INCLUDING, WITHOUT LIMITATION, SATISFACTORY QUALITY OR ACCURACY OF DIMENSIONS.

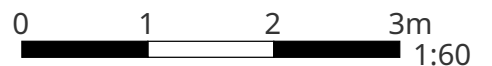

17 Labanka Crescent

Garage

Width: 2.99 m
Length: 5.97 m
Area: 17.88 m²
Perimeter: 17.93 m

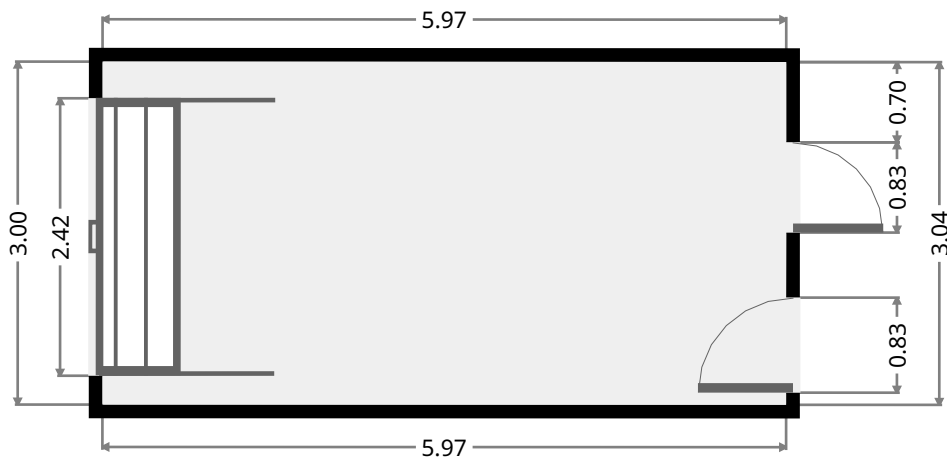
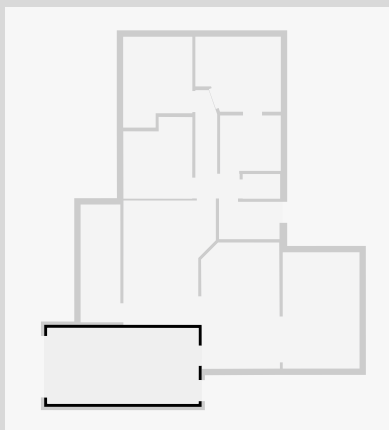

Outdoor Area

Width: 3.03 m
Length: 4.59 m
Area: 13.90 m²
Perimeter: 15.24 m

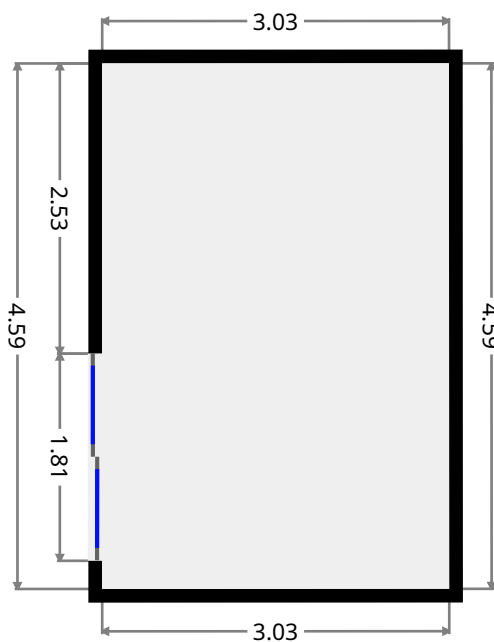
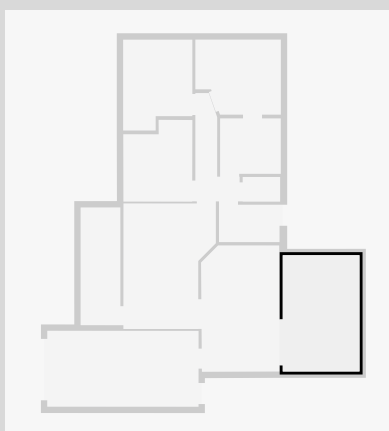

17 Labanka Crescent

Hall

Width: 1.75 m
 Length: 4.27 m
 Area: 4.38 m²
 Perimeter: 11.77 m

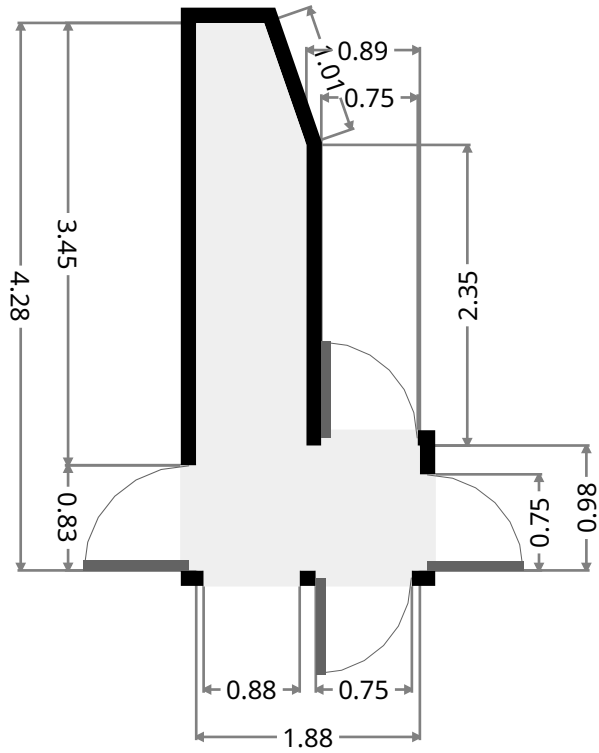
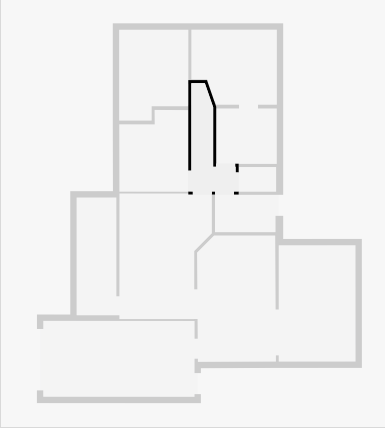

Laundry Room

Width: 1.48 m
 Length: 2.39 m
 Area: 3.52 m²
 Perimeter: 7.73 m

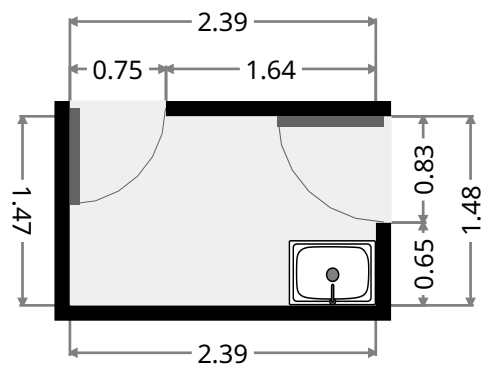
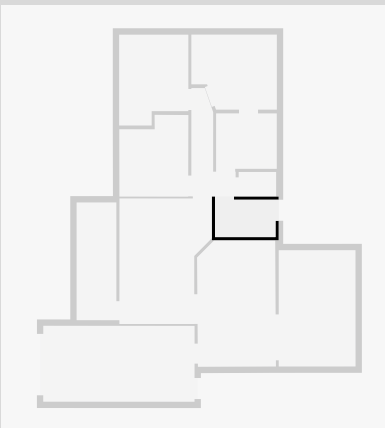

17 Labanka Crescent

Toilet

Width: 0.97 m
Length: 1.48 m
Area: 1.44 m²
Perimeter: 4.90 m

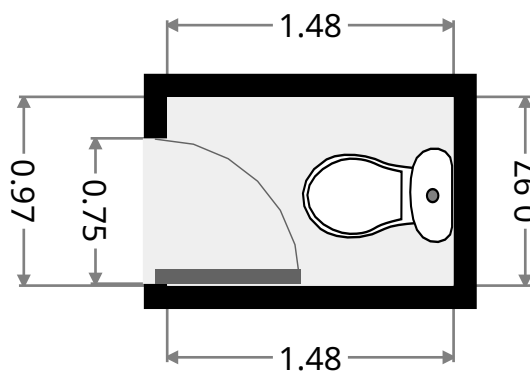
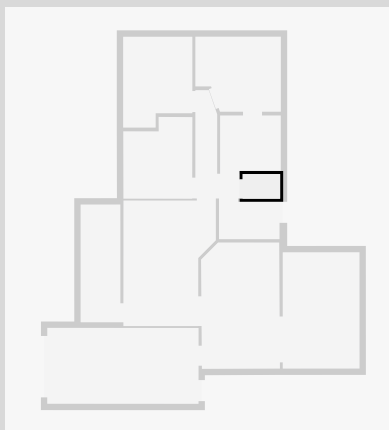

Bathroom

Width: 2.19 m
Length: 2.40 m
Area: 5.23 m²
Perimeter: 9.16 m

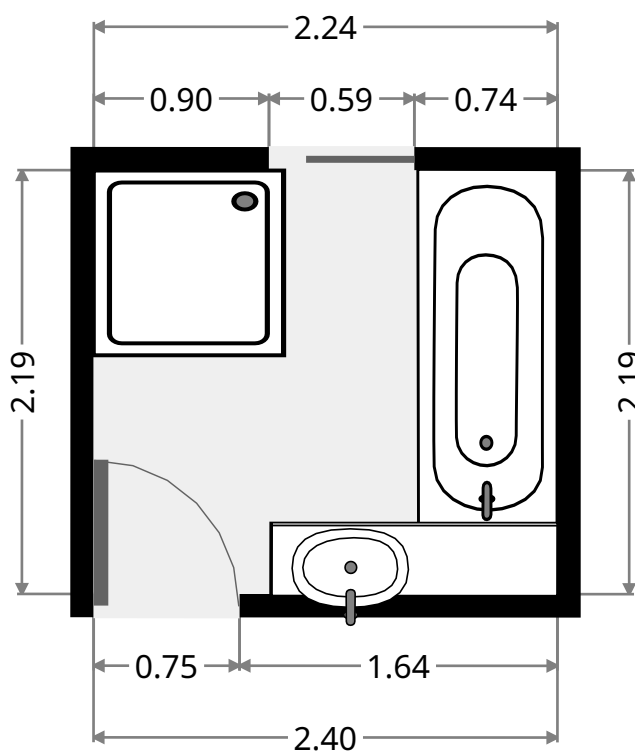
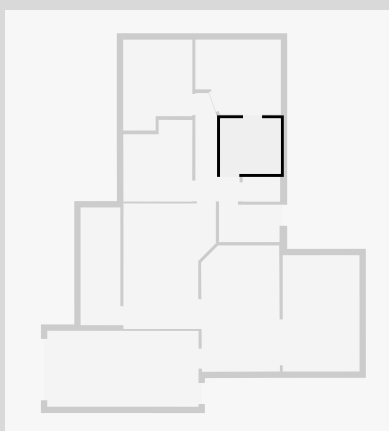

17 Labanka Crescent

Bedroom

Width: 2.96 m
 Length: 3.37 m
 Area: 9.19 m²
 Perimeter: 12.38 m

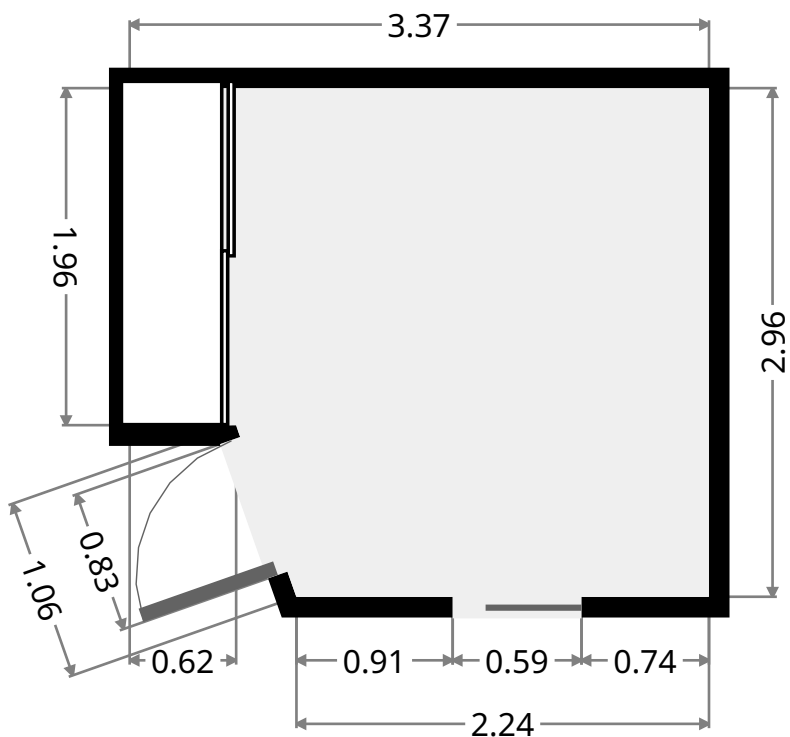
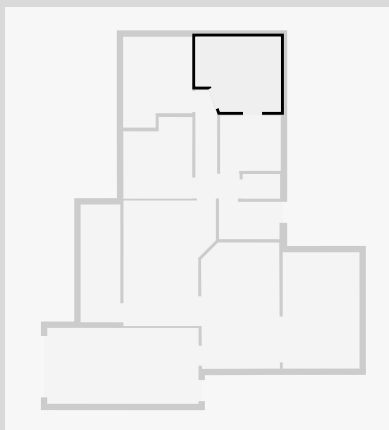

Bedroom

Width: 2.73 m
 Length: 3.58 m
 Area: 8.97 m²
 Perimeter: 12.63 m

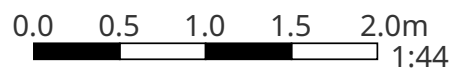
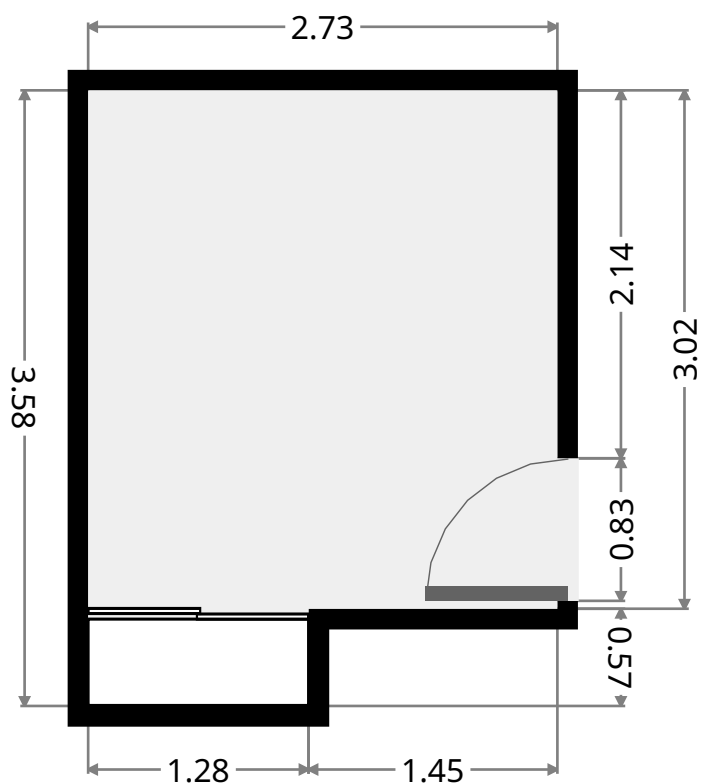
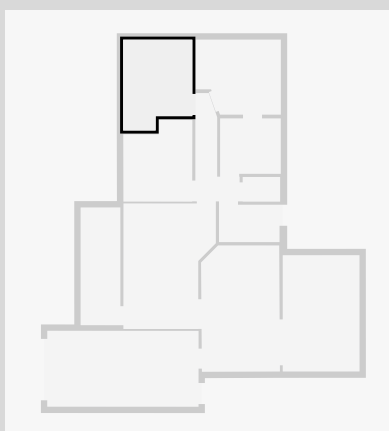

THIS FLOORPLAN IS PROVIDED WITHOUT WARRANTY OF ANY KIND. SENSOPIA DISCLAIMS ANY WARRANTY INCLUDING, WITHOUT LIMITATION, SATISFACTORY QUALITY OR ACCURACY OF DIMENSIONS.

17 Labanka Crescent

Bedroom

Width: 2.73 m
Length: 3.22 m
Area: 7.98 m²
Perimeter: 11.90 m

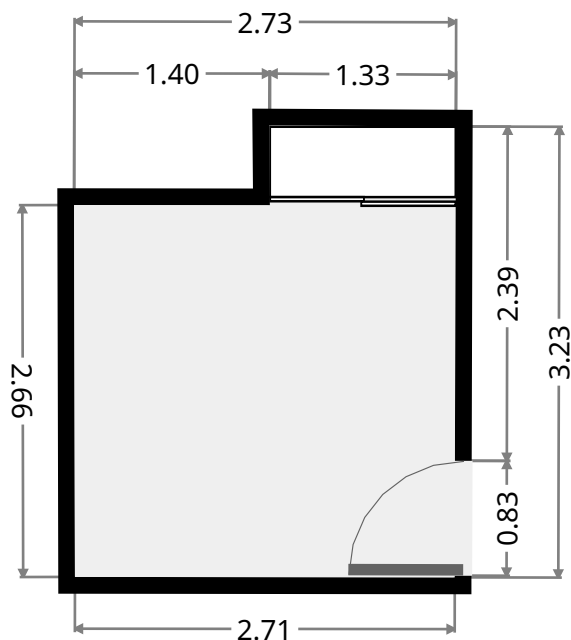
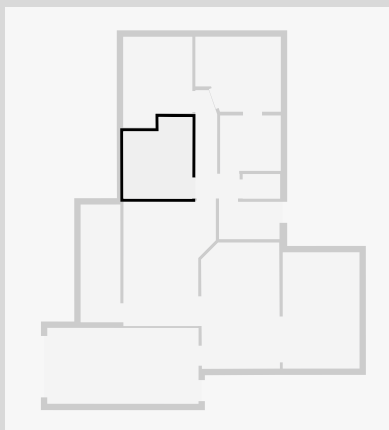

Front Verandah

Width: 1.57 m
Length: 4.65 m
Area: 7.29 m²
Perimeter: 12.43 m

