

17 Cowap Street

SUBMITTED BY

Ray White Rockhampton Casey
stockers@cqoz.com

CREATED ON

2018-07-31

Floors

2

▼ Ground Floor

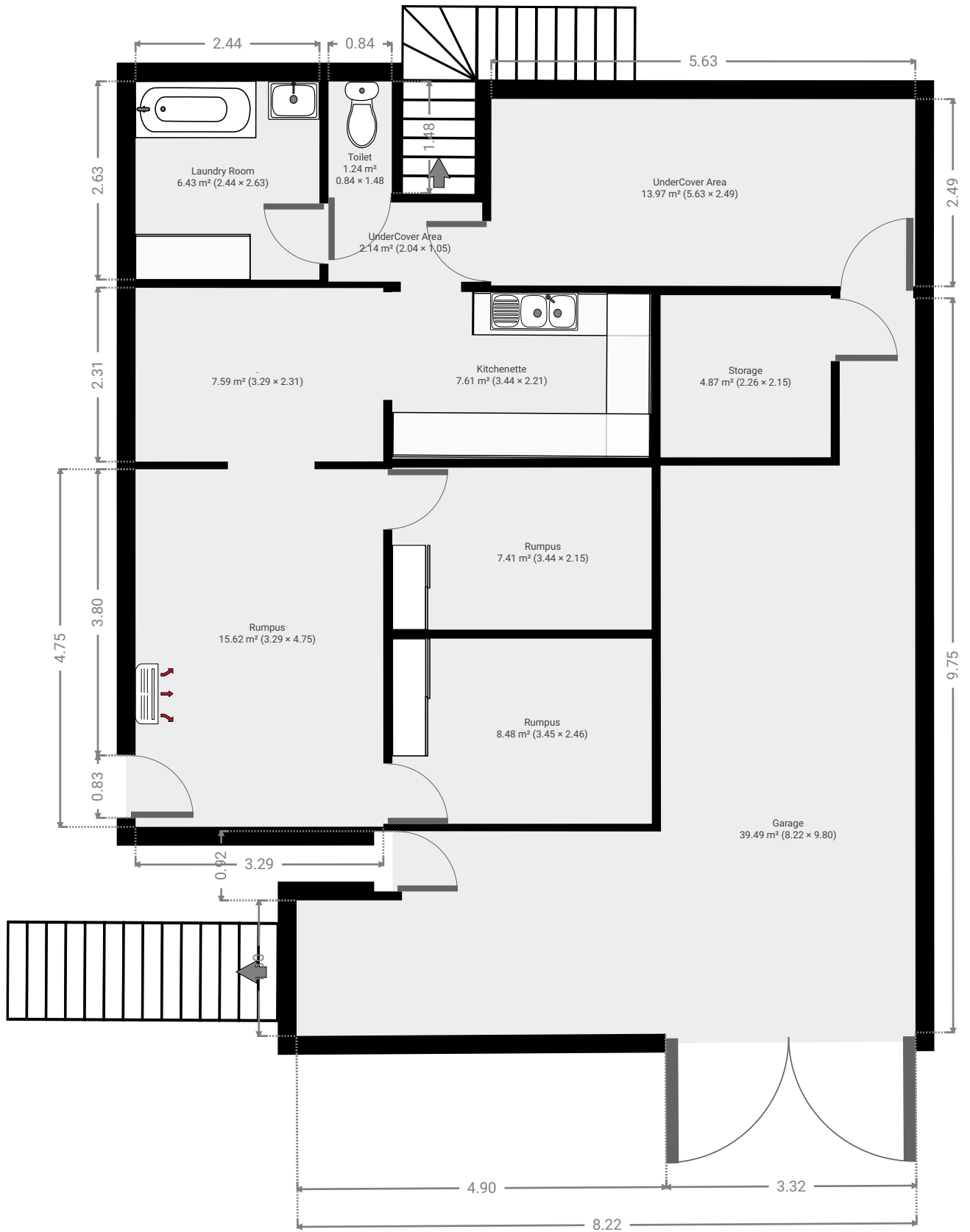

▼ **Rumpus**
Ground Floor

WIDTH: 3.44 m • LENGTH: 2.15 m
AREA: 7.41 m² • PERIMETER: 11.19 m

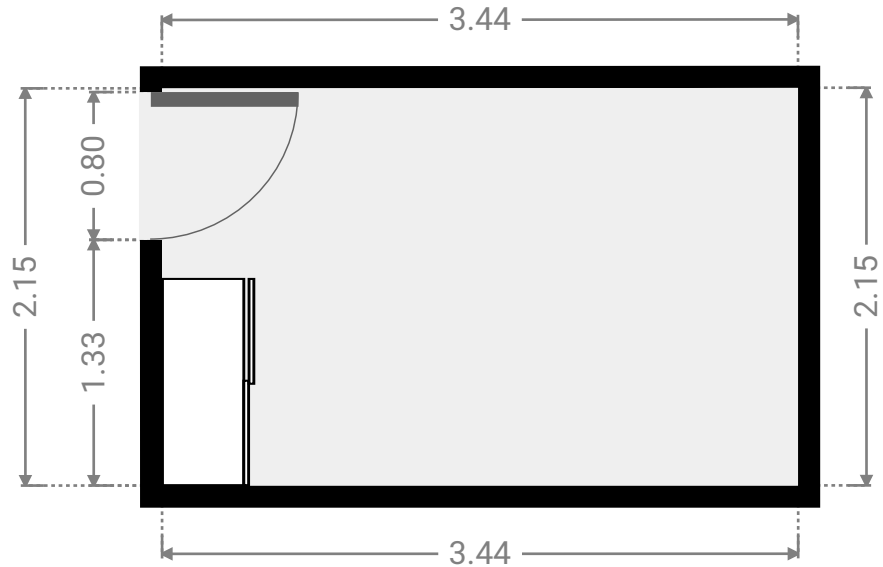
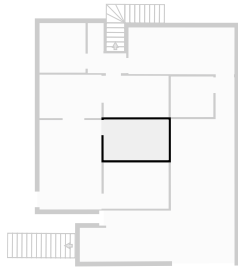

▼ **.**
Ground Floor

WIDTH: 3.29 m • LENGTH: 2.31 m
AREA: 7.59 m² • PERIMETER: 11.19 m

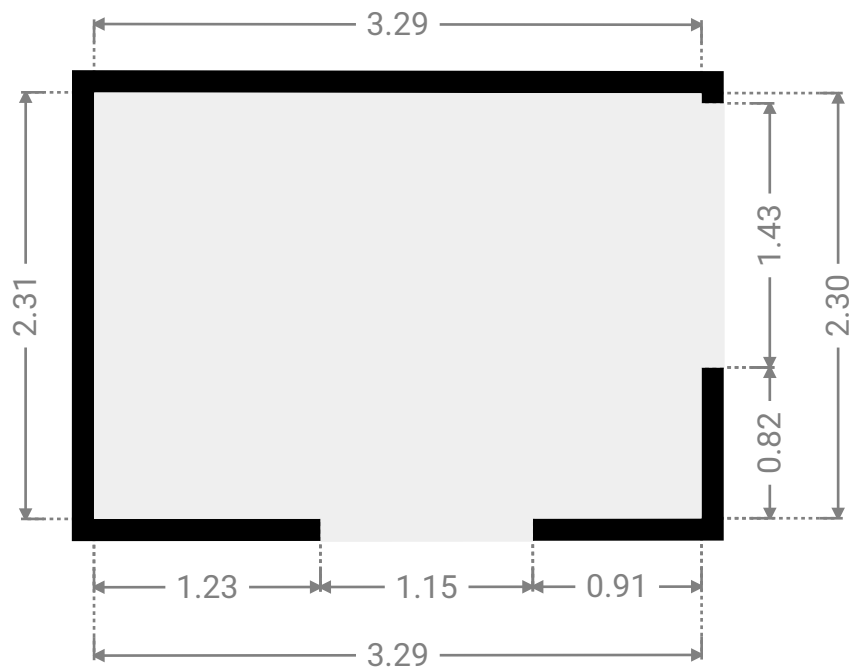
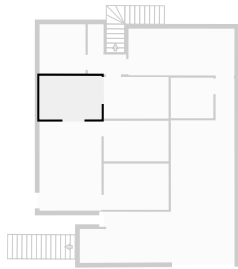

▼ **Kitchenette**
Ground Floor

WIDTH: 3.43 m • LENGTH: 2.21 m
AREA: 7.61 m² • PERIMETER: 11.31 m

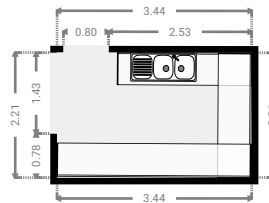
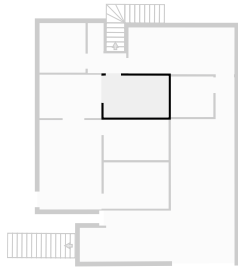

▼ **Garage**
Ground Floor

WIDTH: 8.22 m • LENGTH: 9.79 m
AREA: 39.49 m² • PERIMETER: 35.99 m

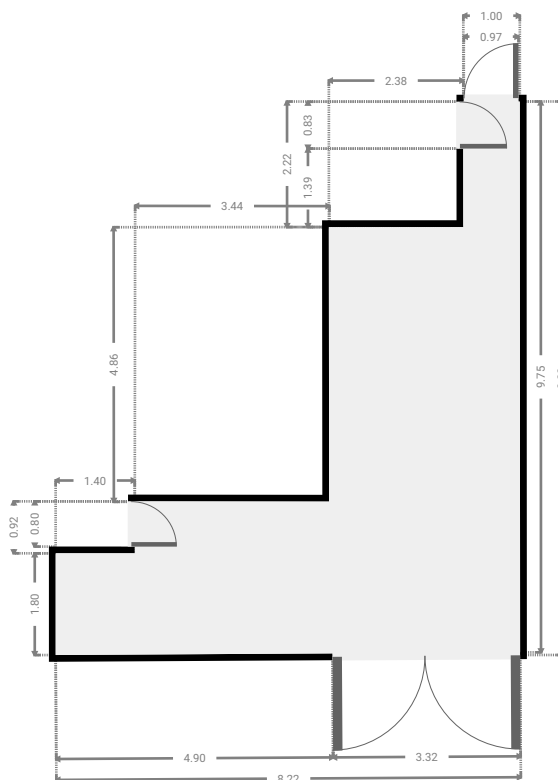
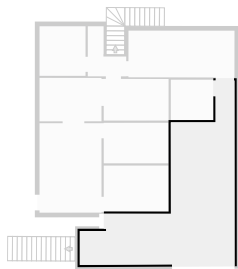

▼ Storage
Ground Floor

WIDTH: 2.26 m • LENGTH: 2.15 m
AREA: 4.87 m² • PERIMETER: 8.83 m

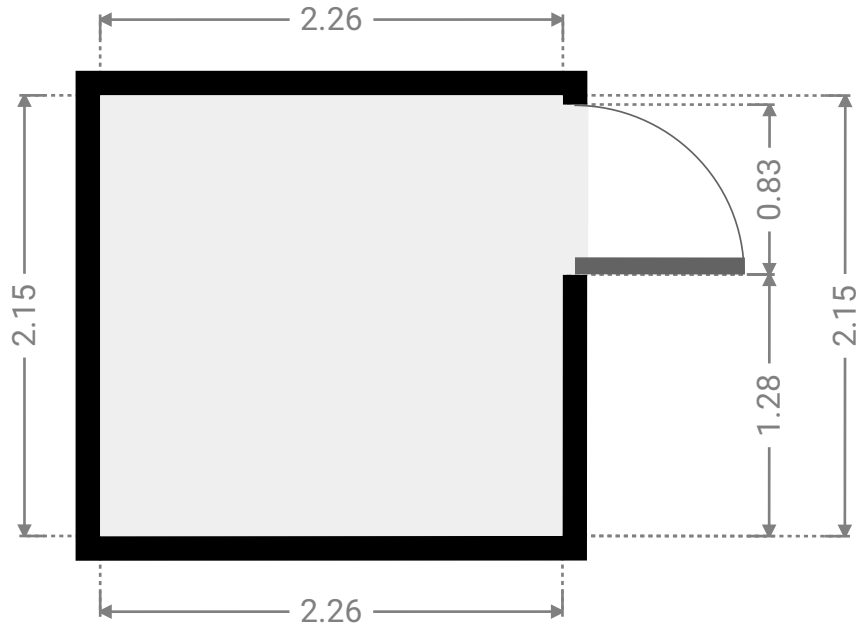
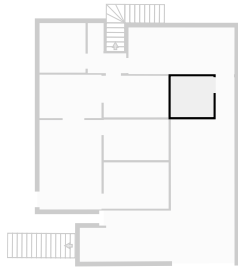

▼ UnderCover Area
Ground Floor

WIDTH: 2.04 m • LENGTH: 1.05 m
AREA: 2.14 m² • PERIMETER: 6.18 m

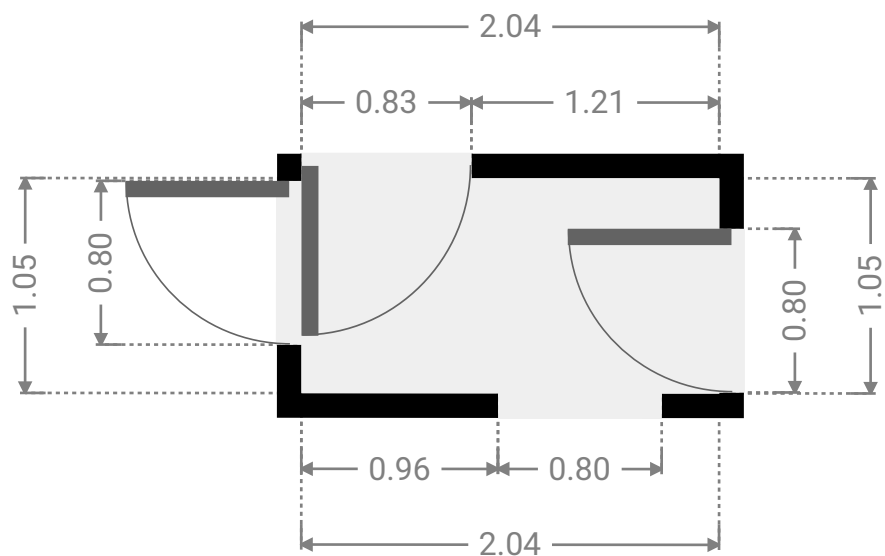
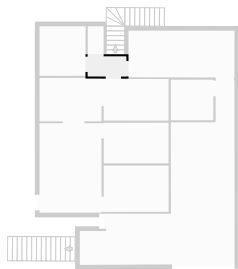

▼ **Laundry Room**
Ground Floor

WIDTH: 2.43 m • LENGTH: 2.63 m
AREA: 6.43 m² • PERIMETER: 10.15 m

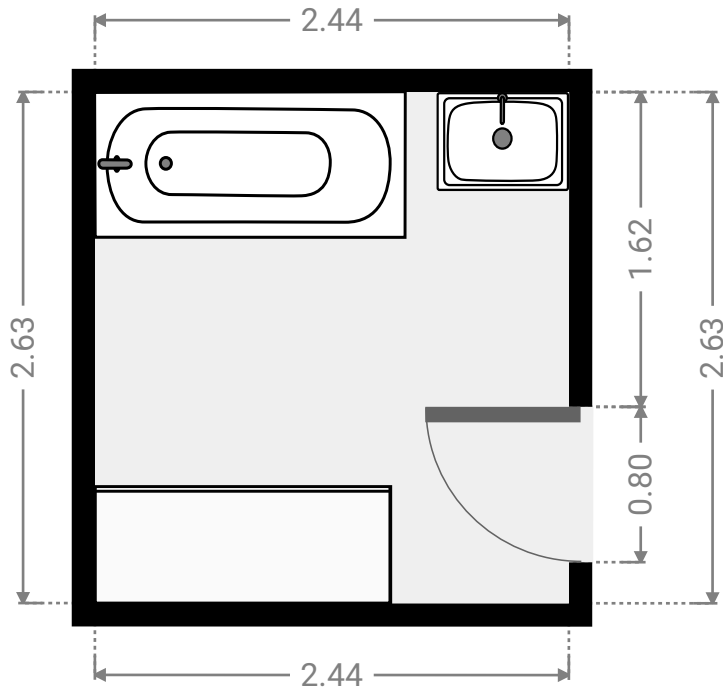
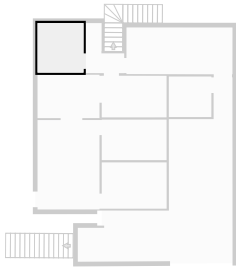

▼ **Toilet**
Ground Floor

WIDTH: 0.84 m • LENGTH: 1.48 m
AREA: 1.24 m² • PERIMETER: 4.64 m

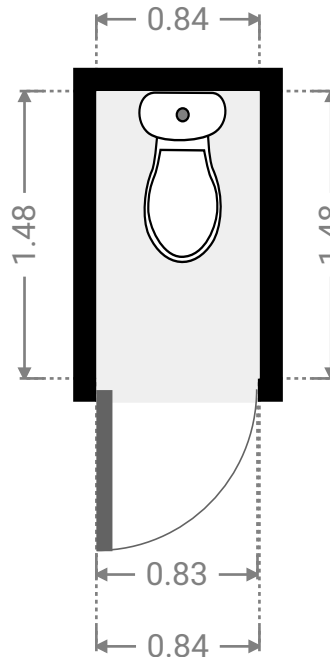
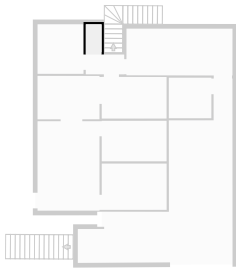

▼ UnderCover Area
Ground Floor

WIDTH: 5.63 m • LENGTH: 2.49 m
AREA: 13.97 m² • PERIMETER: 16.22 m

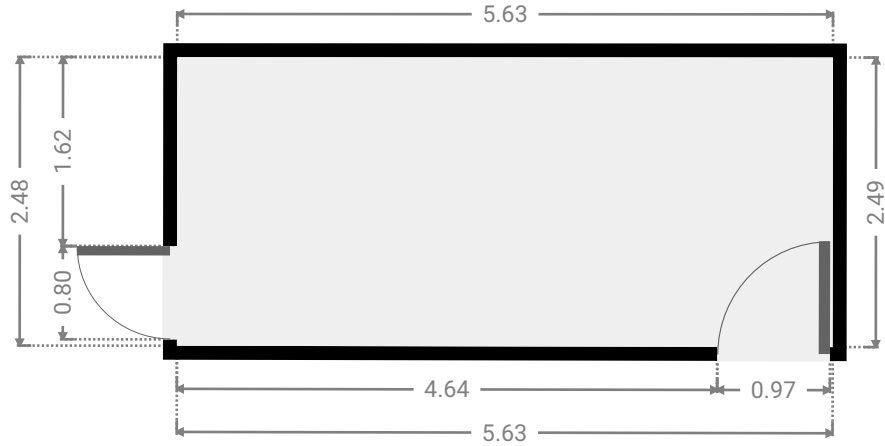
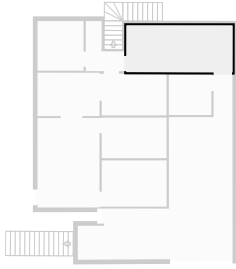

▼ Rumpus
Ground Floor

WIDTH: 6.85 m • LENGTH: 4.75 m
AREA: 15.62 m² • PERIMETER: 16.08 m

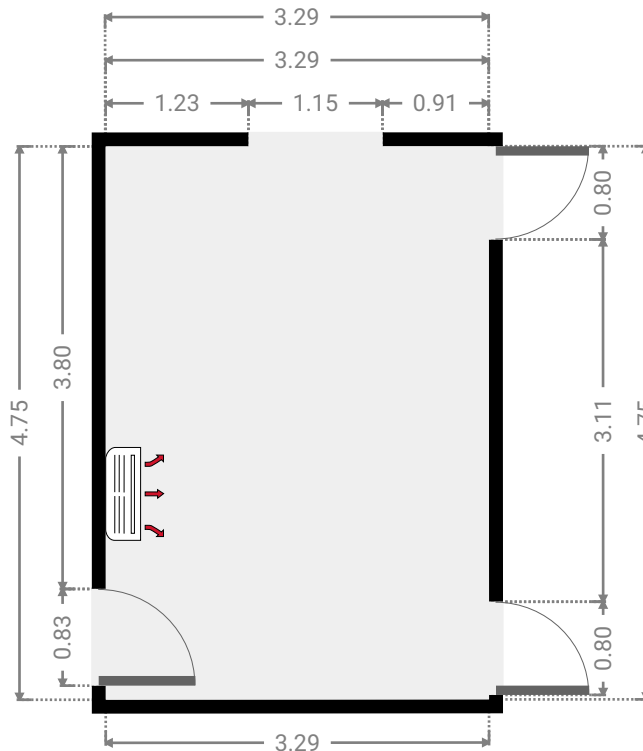
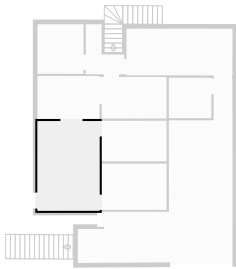

▼ **Rumpus**
Ground Floor

WIDTH: 3.45 m • LENGTH: 2.46 m
AREA: 8.48 m² • PERIMETER: 11.81 m

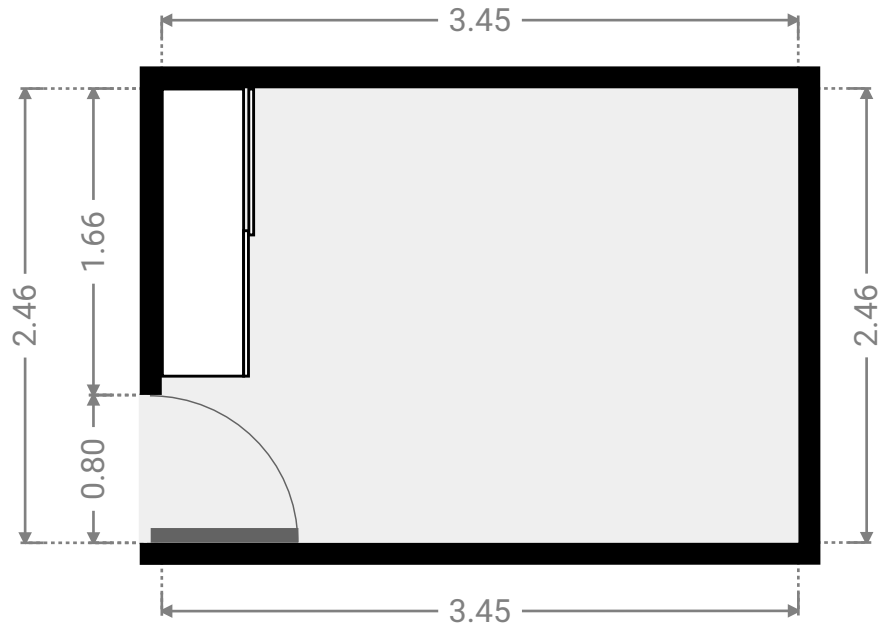
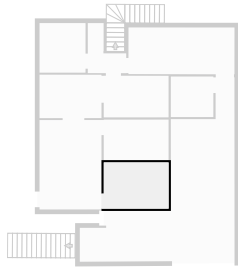

▼ 1st Floor



▼ **Verandah**
1st Floor

WIDTH: 4.74 m • LENGTH: 2.44 m
AREA: 8.23 m² • PERIMETER: 14.36 m

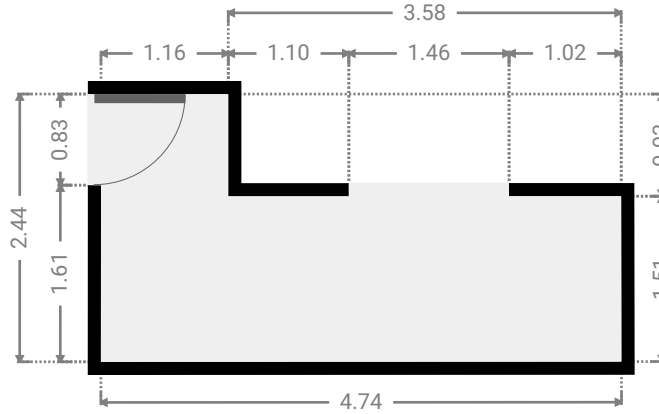
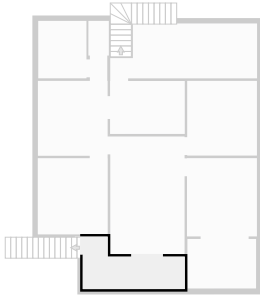

▼ **Living Room**
1st Floor

WIDTH: 3.45 m • LENGTH: 5.46 m
AREA: 18.84 m² • PERIMETER: 17.82 m

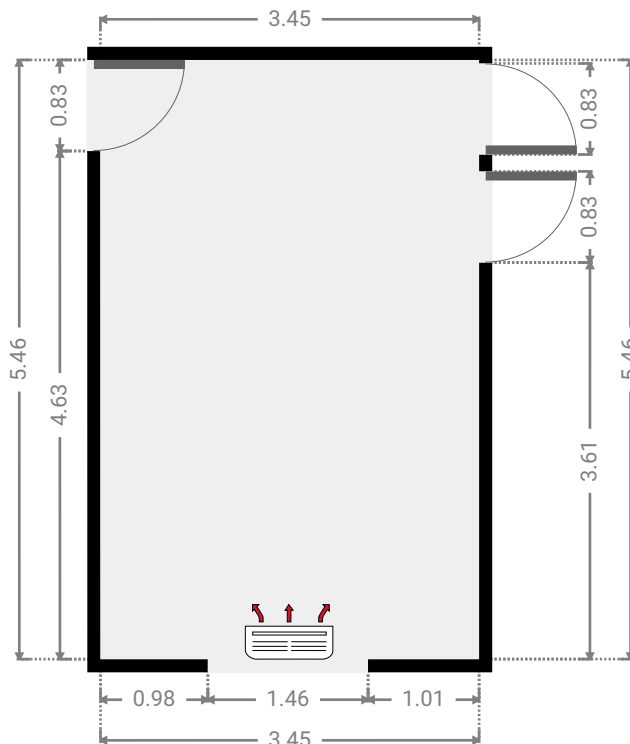
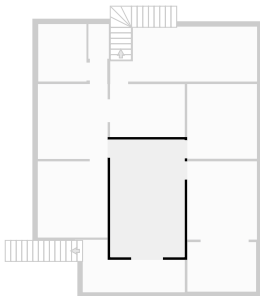

▼ **Bedroom**
1st Floor

WIDTH: 3.25 m • LENGTH: 3.64 m
AREA: 11.82 m² • PERIMETER: 13.77 m

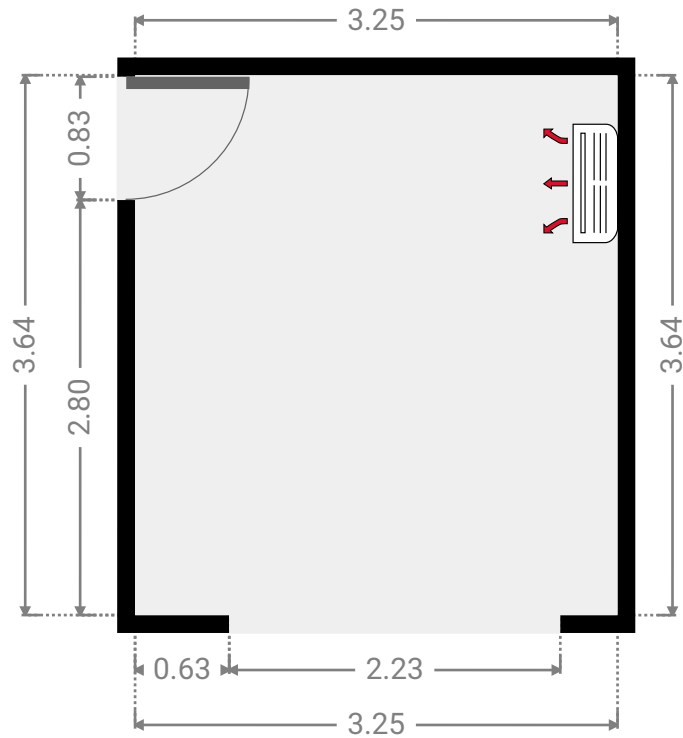
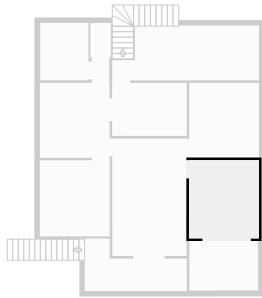

▼ **Bedroom**
1st Floor

WIDTH: 3.24 m • LENGTH: 3.47 m
AREA: 11.24 m² • PERIMETER: 13.42 m

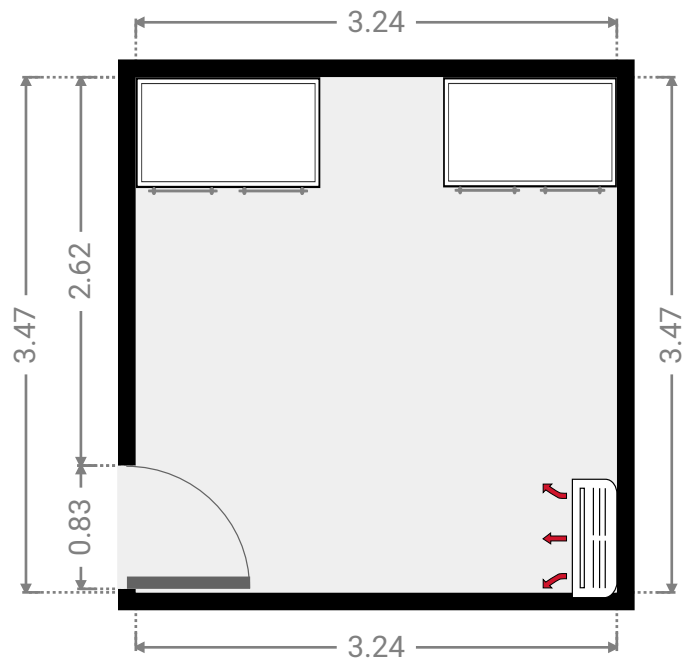
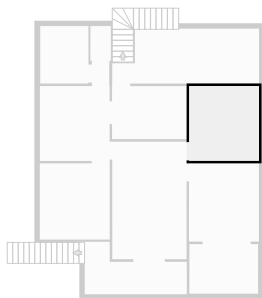

▼ **Dining Room**
1st Floor

WIDTH: 3.24 m • LENGTH: 3.48 m
AREA: 11.27 m² • PERIMETER: 13.44 m

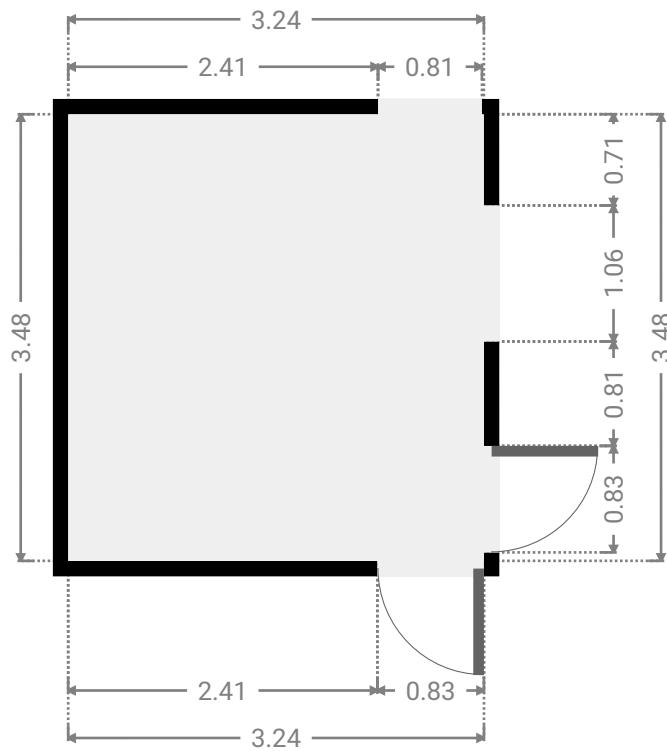
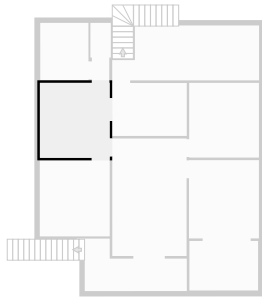

▼ **Bedroom**
1st Floor

WIDTH: 3.25 m • LENGTH: 3.54 m
AREA: 11.50 m² • PERIMETER: 13.58 m

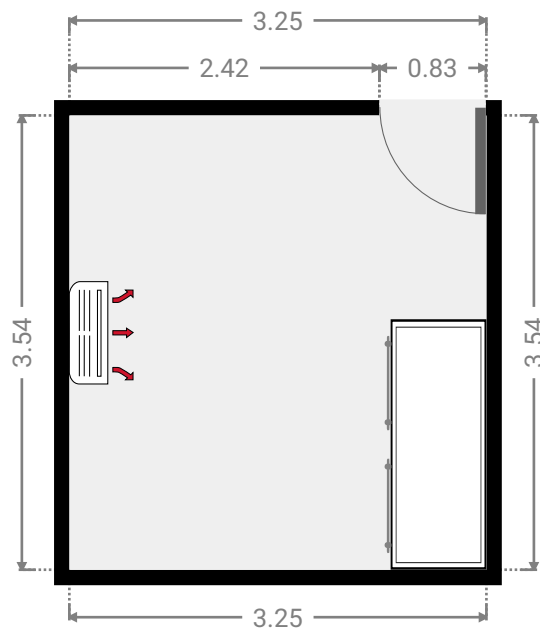
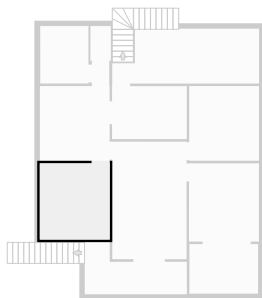

▼ Kitchen
1st Floor

WIDTH: 3.47 m • LENGTH: 2.46 m
AREA: 8.54 m² • PERIMETER: 11.86 m

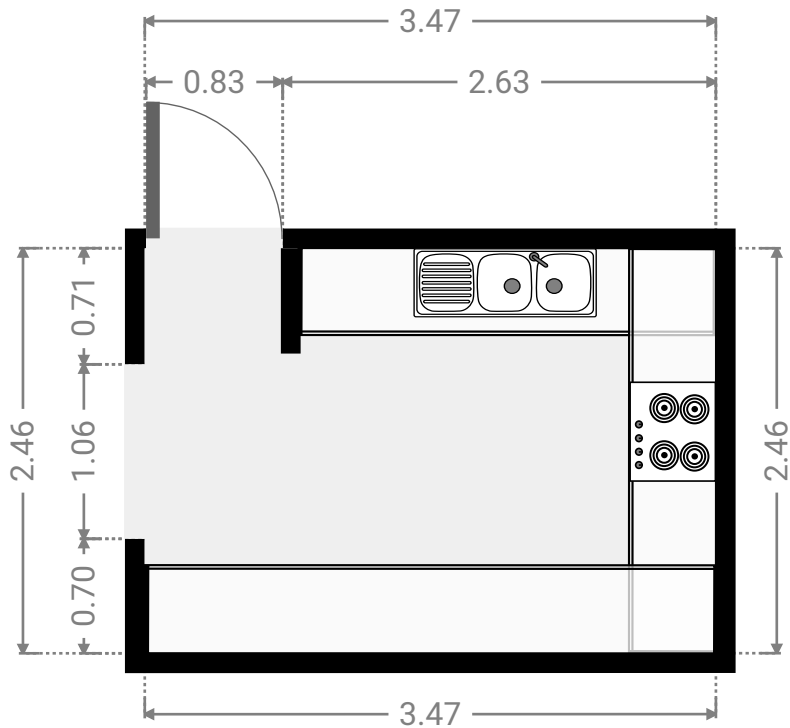
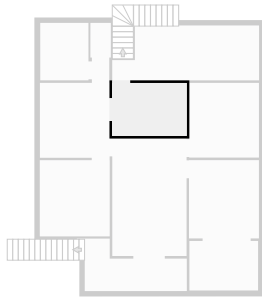

▼ Hall
1st Floor

WIDTH: 0.81 m • LENGTH: 0.94 m
AREA: 0.76 m² • PERIMETER: 3.50 m

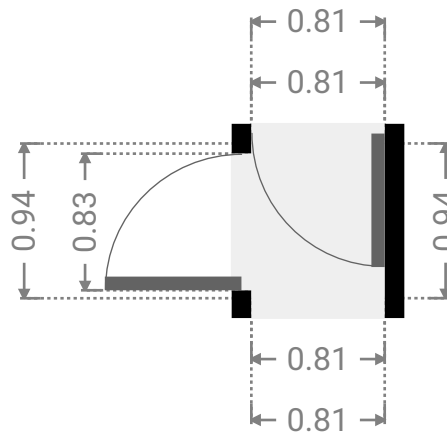
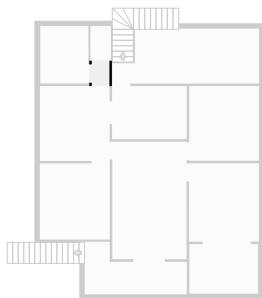

▼ **Toilet**
1st Floor

WIDTH: 0.95 m • LENGTH: 1.61 m
AREA: 1.53 m² • PERIMETER: 5.12 m

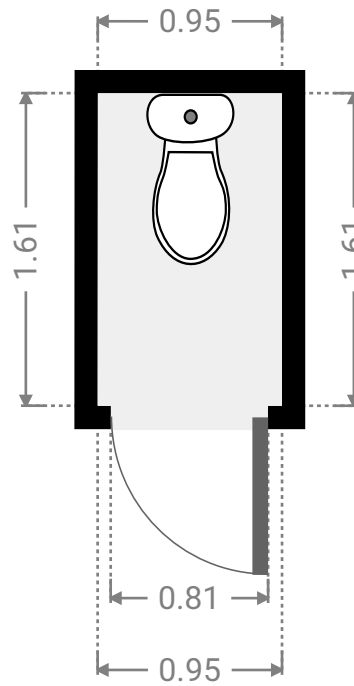
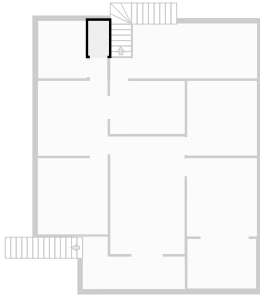

▼ **Bathroom**
1st Floor

WIDTH: 2.24 m • LENGTH: 2.67 m
AREA: 5.98 m² • PERIMETER: 9.82 m

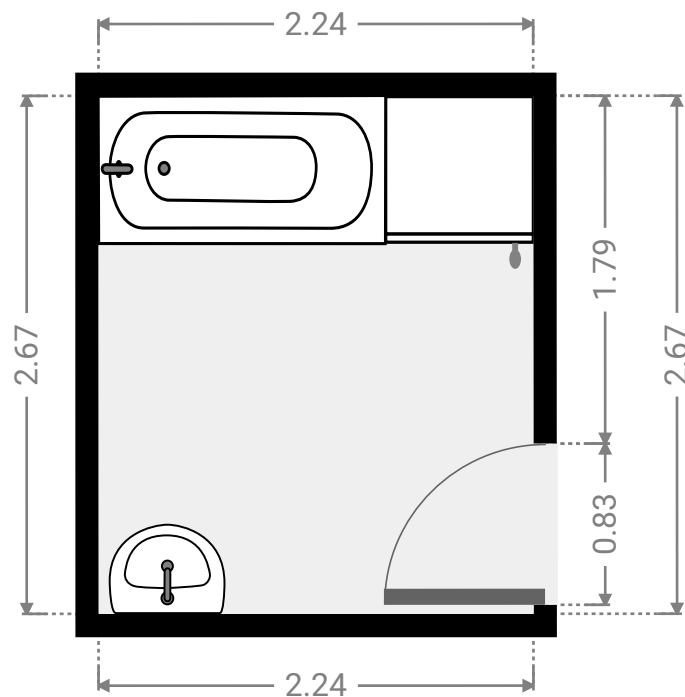
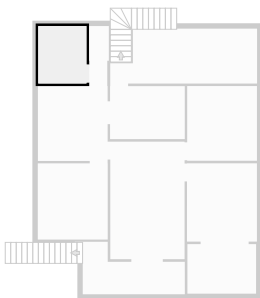

▼ **Rear Deck**
1st Floor

WIDTH: 6.82 m • LENGTH: 2.55 m
AREA: 15.70 m² • PERIMETER: 18.74 m

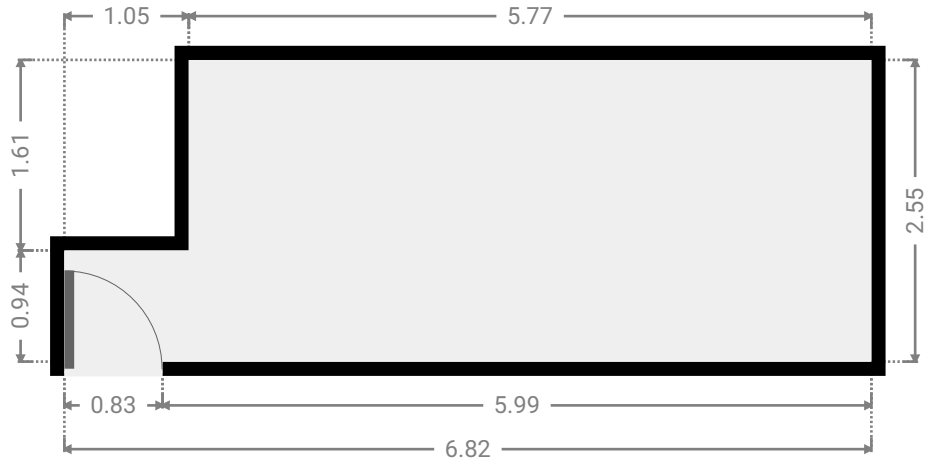
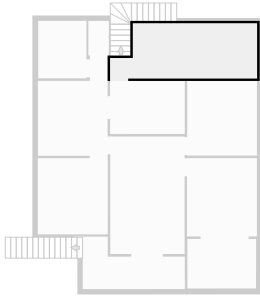

▼ **Closet**
1st Floor

WIDTH: 3.19 m • LENGTH: 2.30 m
AREA: 7.34 m² • PERIMETER: 10.98 m

