

# 16 Neill Street

## Ground Floor

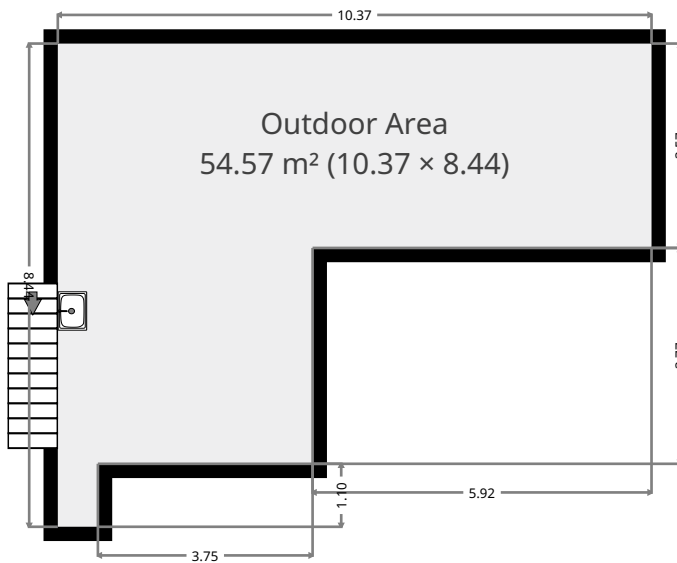

THIS FLOORPLAN IS PROVIDED WITHOUT WARRANTY OF ANY KIND. SENSOPIA DISCLAIMS ANY WARRANTY INCLUDING, WITHOUT LIMITATION, SATISFACTORY QUALITY OR ACCURACY OF DIMENSIONS.

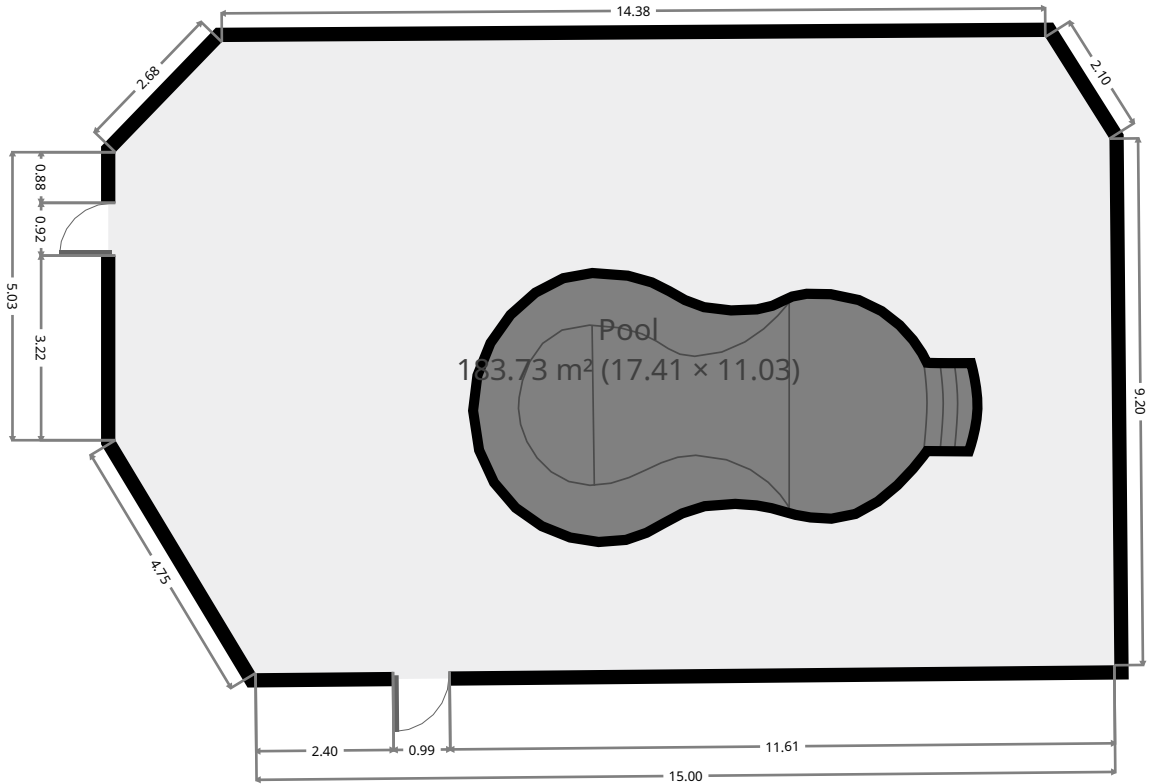

# 16 Neill Street

## Outdoor Area

Width: 8.44 m  
Length: 10.37 m  
Area: 54.57 m<sup>2</sup>  
Perimeter: 37.62 m

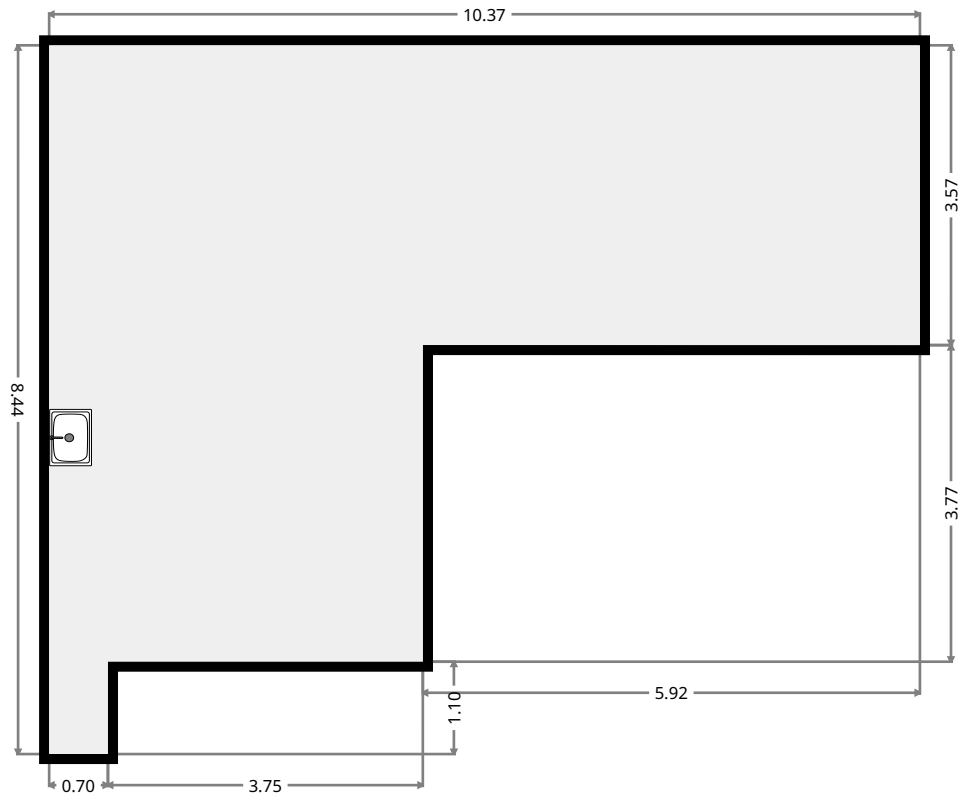
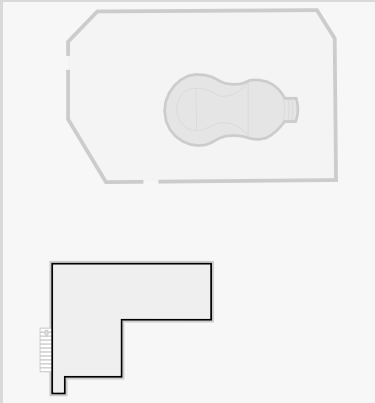

# 16 Neill Street

## Pool

Width: 11.03 m  
Length: 17.41 m  
Area: 183.73 m<sup>2</sup>  
Perimeter: 53.14 m

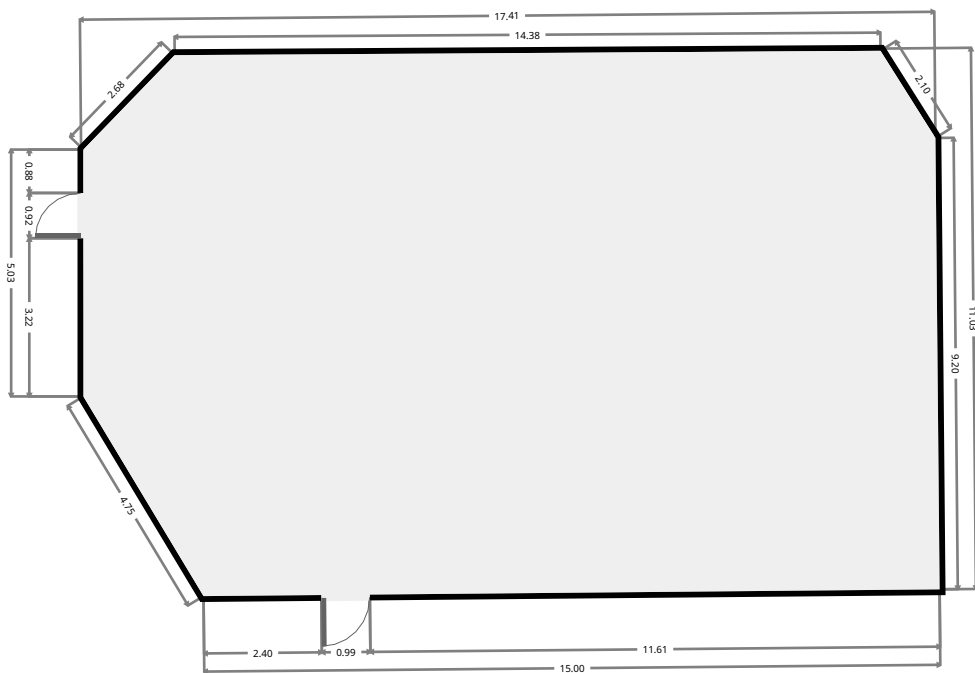
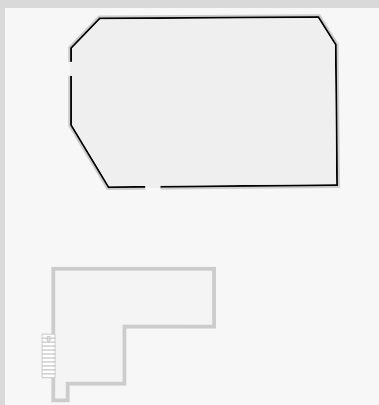

THIS FLOORPLAN IS PROVIDED WITHOUT WARRANTY OF ANY KIND. SENSOPIA DISCLAIMS ANY WARRANTY INCLUDING, WITHOUT LIMITATION, SATISFACTORY QUALITY OR ACCURACY OF DIMENSIONS.



# 16 Neill Street

## 1st Floor

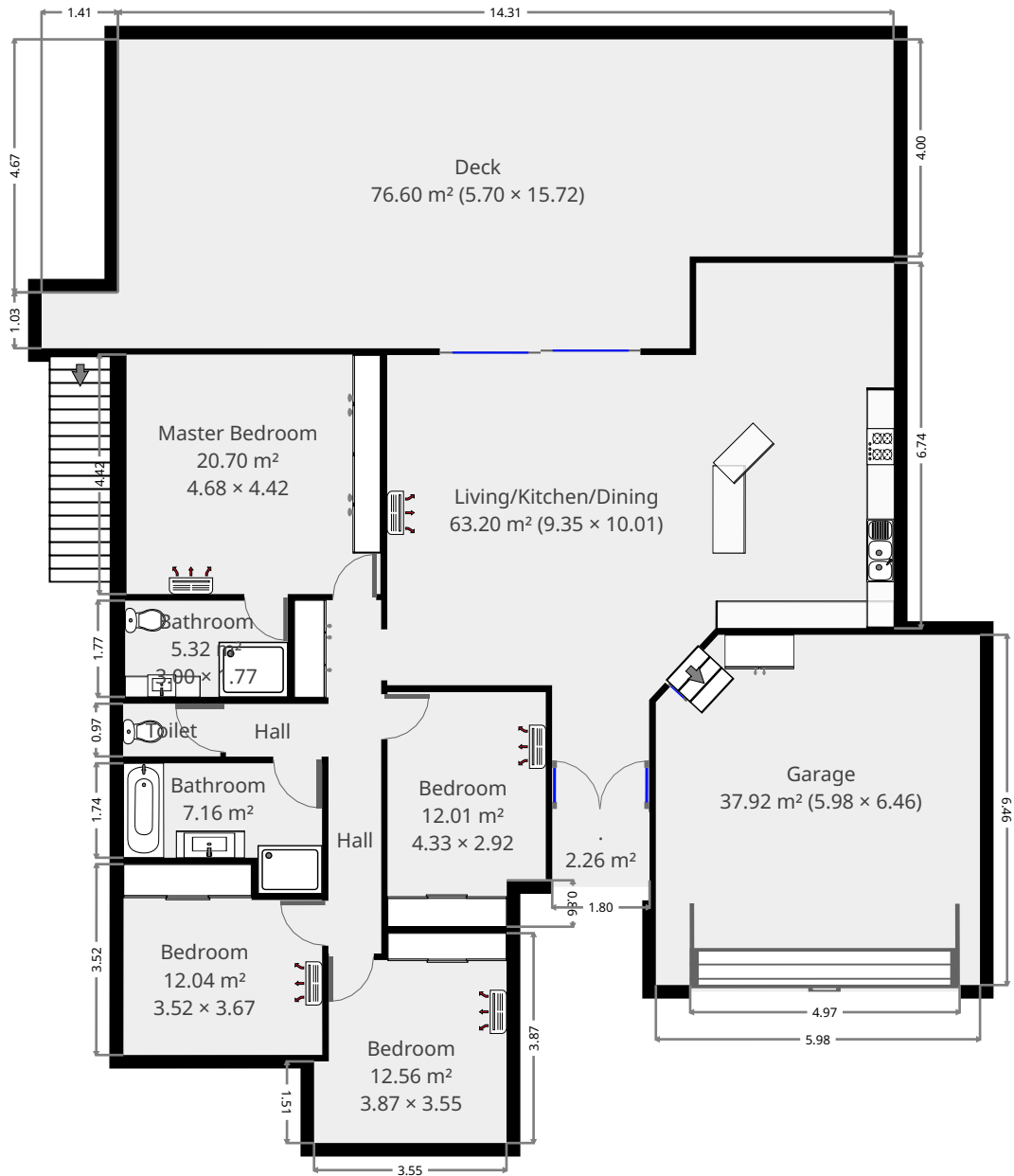

THIS FLOORPLAN IS PROVIDED WITHOUT WARRANTY OF ANY KIND. SENSOPIA DISCLAIMS ANY WARRANTY INCLUDING, WITHOUT LIMITATION, SATISFACTORY QUALITY OR ACCURACY OF DIMENSIONS.



# 16 Neill Street

## Living/Kitchen/Dining

Width: 9.35 m  
Length: 10.01 m  
Area: 63.20 m<sup>2</sup>  
Perimeter: 37.98 m

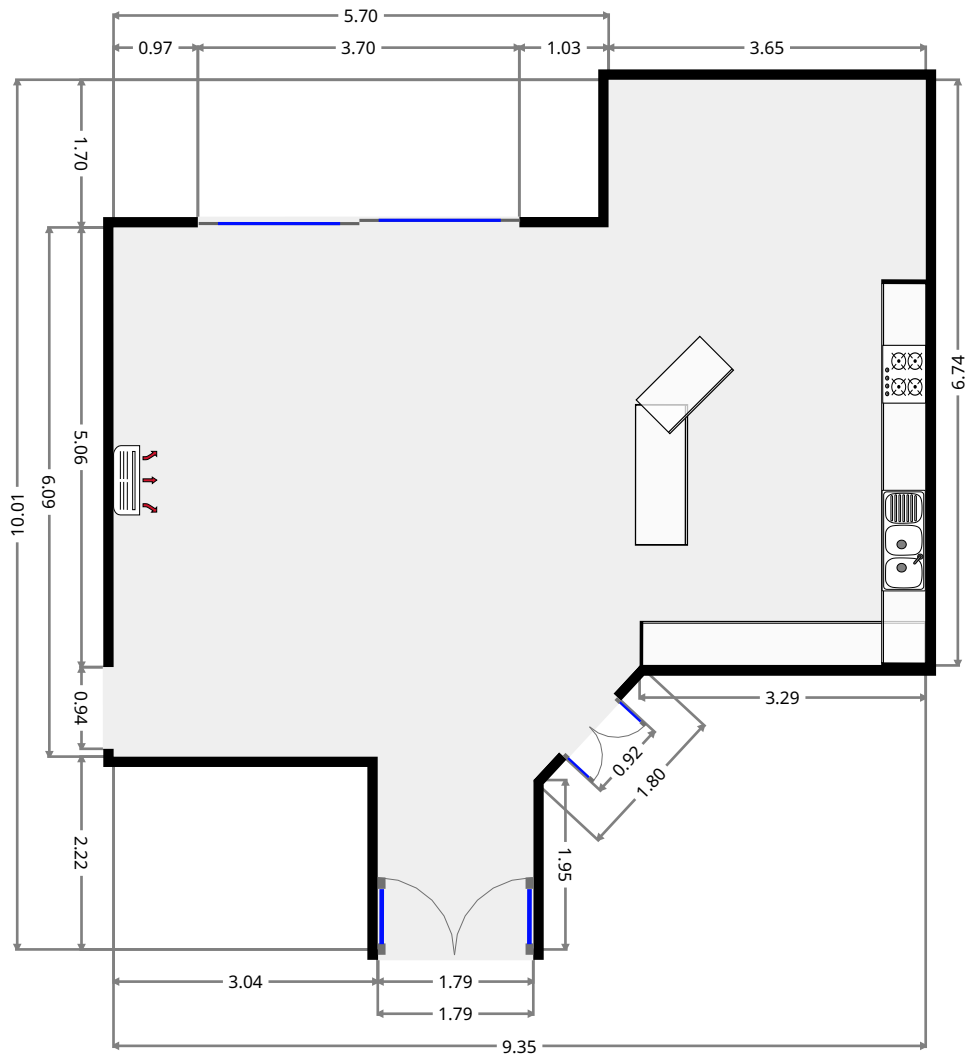
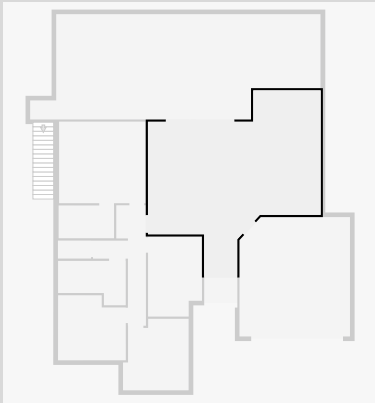

THIS FLOORPLAN IS PROVIDED WITHOUT WARRANTY OF ANY KIND. SENSOPIA DISCLAIMS ANY WARRANTY INCLUDING, WITHOUT LIMITATION, SATISFACTORY QUALITY OR ACCURACY OF DIMENSIONS.

# 16 Neill Street

## Hall

Width: 1.60 m  
 Length: 6.52 m  
 Area: 7.48 m<sup>2</sup>  
 Perimeter: 16.25 m

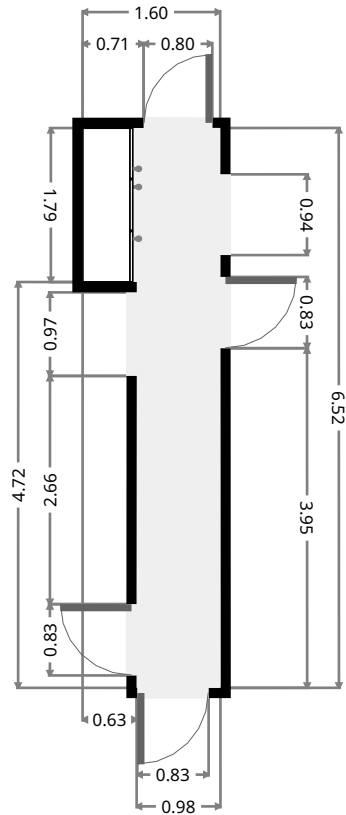
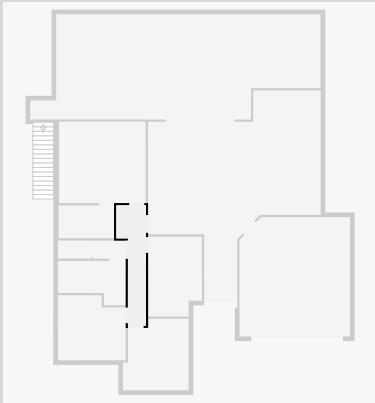

## Master Bedroom

Width: 4.42 m  
 Length: 4.68 m  
 Area: 20.70 m<sup>2</sup>  
 Perimeter: 18.20 m

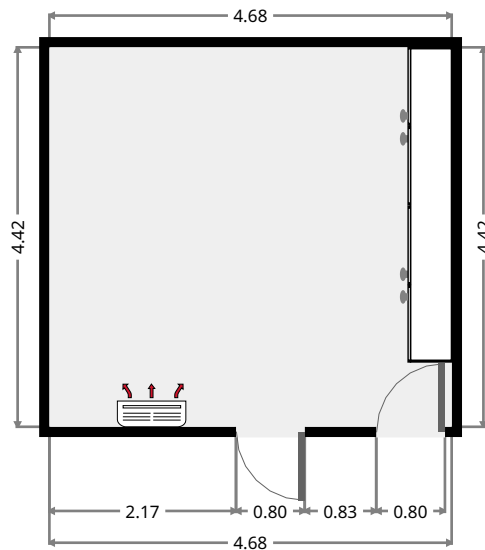
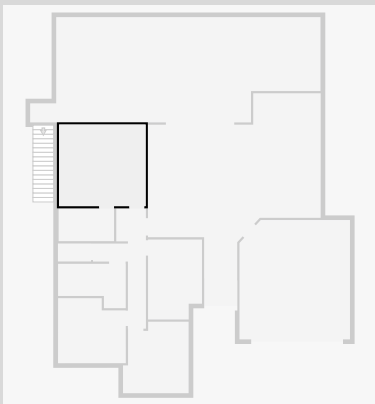

THIS FLOORPLAN IS PROVIDED WITHOUT WARRANTY OF ANY KIND. SENSOPIA DISCLAIMS ANY WARRANTY INCLUDING, WITHOUT LIMITATION, SATISFACTORY QUALITY OR ACCURACY OF DIMENSIONS.



# 16 Neill Street

## Bathroom

Width: 1.77 m  
 Length: 3.00 m  
 Area: 5.32 m<sup>2</sup>  
 Perimeter: 9.55 m

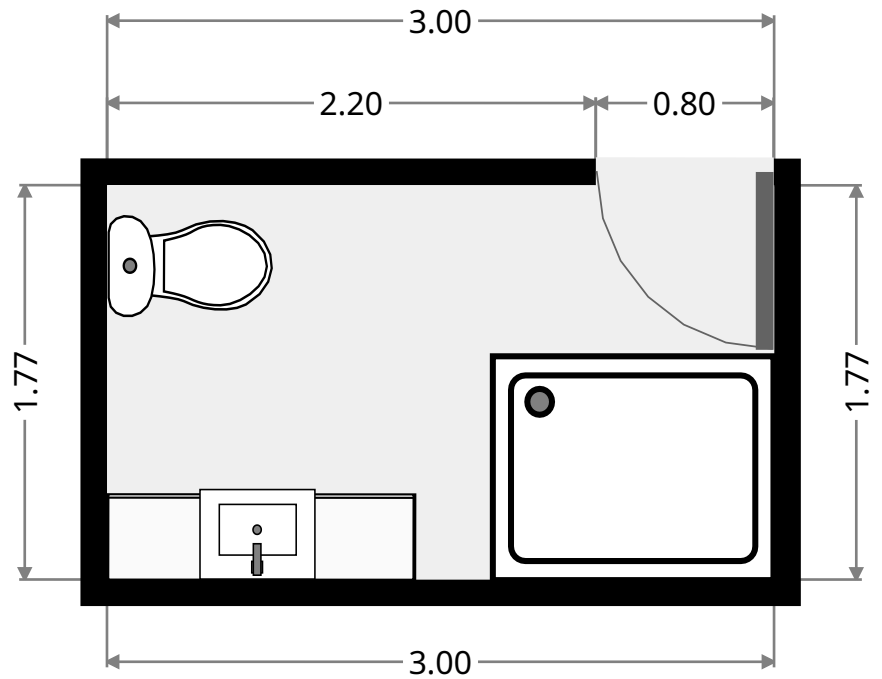
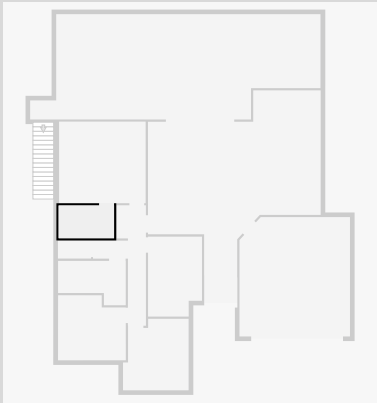

## Hall

Width: 0.97 m  
 Length: 1.78 m  
 Area: 1.73 m<sup>2</sup>  
 Perimeter: 5.51 m

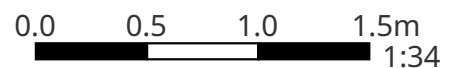
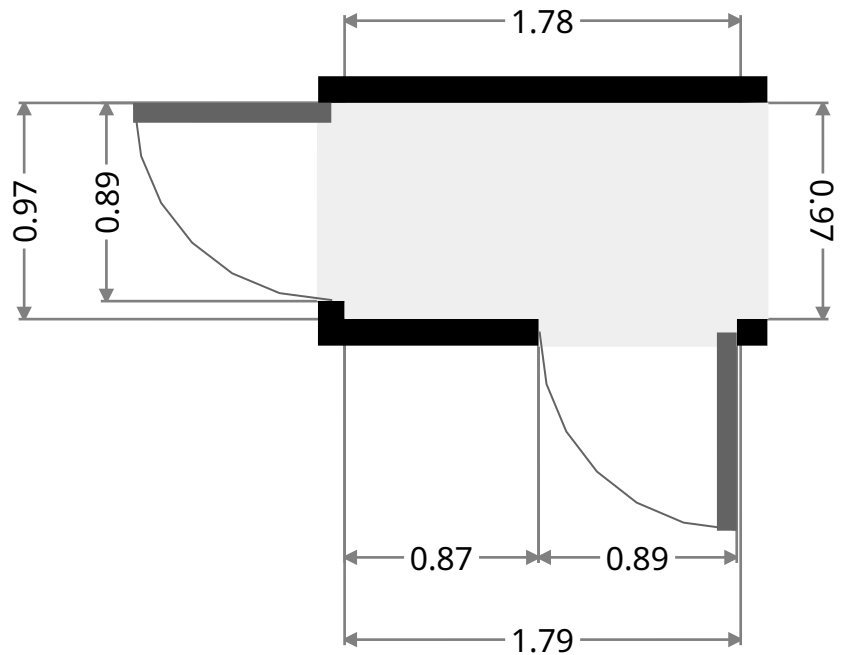
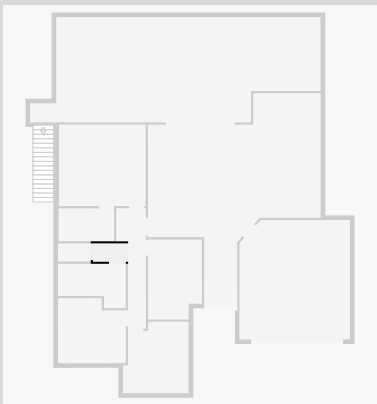

THIS FLOORPLAN IS PROVIDED WITHOUT WARRANTY OF ANY KIND. SENSOPIA DISCLAIMS ANY WARRANTY INCLUDING, WITHOUT LIMITATION, SATISFACTORY QUALITY OR ACCURACY OF DIMENSIONS.

# 16 Neill Street

## Toilet

Width: 0.97 m  
 Length: 1.80 m  
 Area: 1.74 m<sup>2</sup>  
 Perimeter: 5.53 m

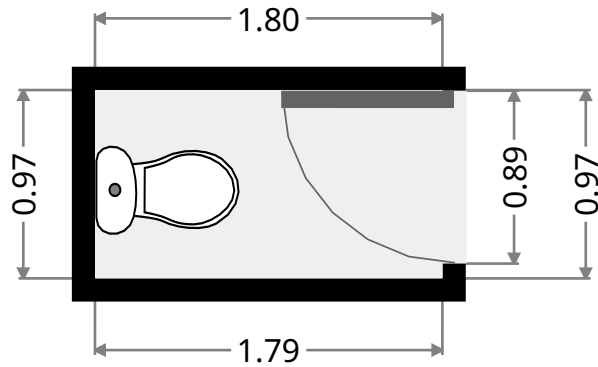
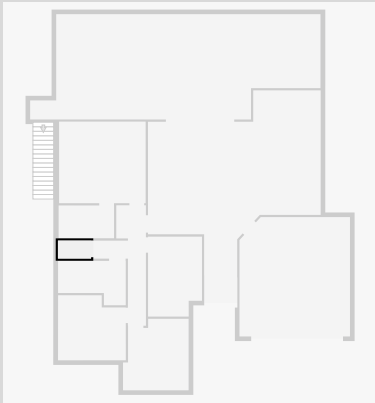

## Bathroom

Width: 2.40 m  
 Length: 3.66 m  
 Area: 7.16 m<sup>2</sup>  
 Perimeter: 12.13 m

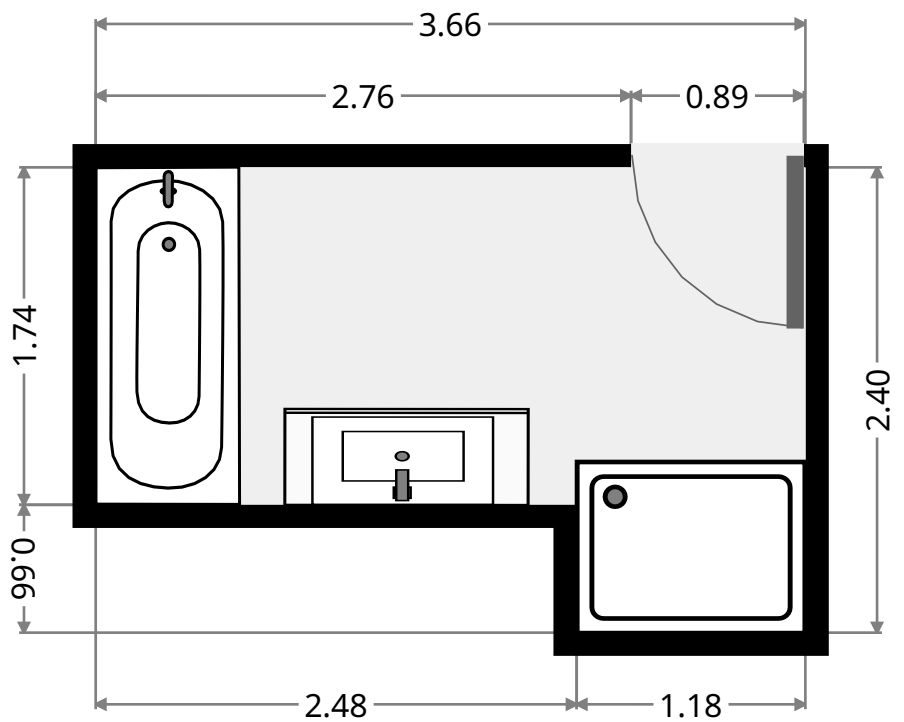
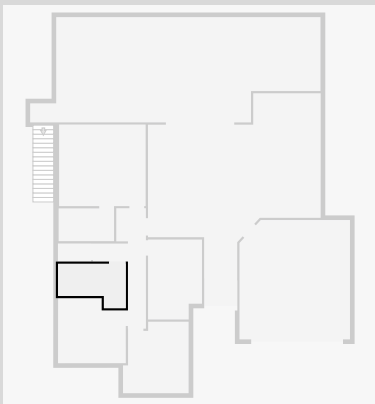

THIS FLOORPLAN IS PROVIDED WITHOUT WARRANTY OF ANY KIND. SENSOPIA DISCLAIMS ANY WARRANTY INCLUDING, WITHOUT LIMITATION, SATISFACTORY QUALITY OR ACCURACY OF DIMENSIONS.

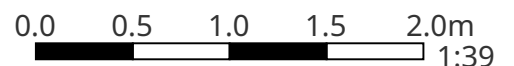



# 16 Neill Street

## Bedroom

Width: 2.92 m  
 Length: 4.33 m  
 Area: 12.01 m<sup>2</sup>  
 Perimeter: 14.49 m

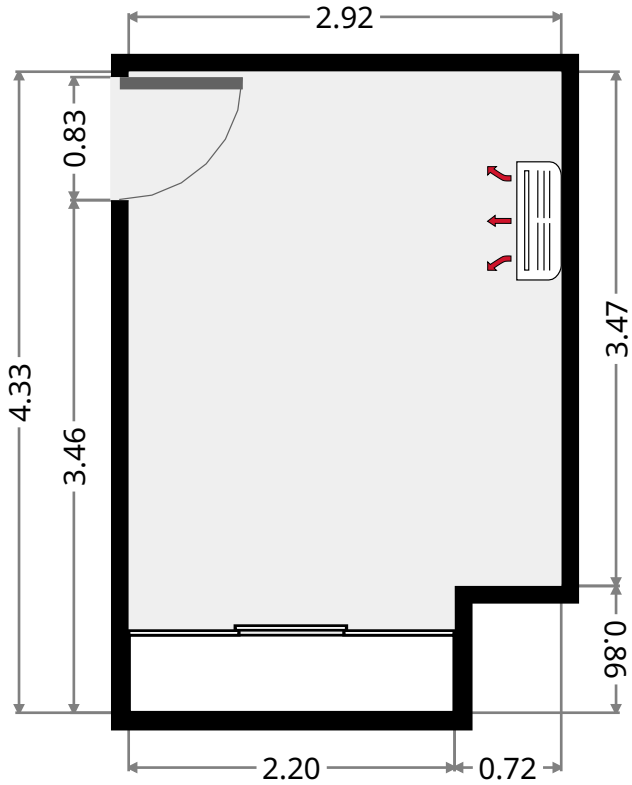
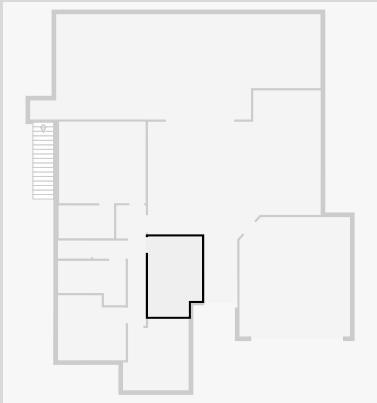

## Bedroom

Width: 3.55 m  
 Length: 3.87 m  
 Area: 12.56 m<sup>2</sup>  
 Perimeter: 14.84 m

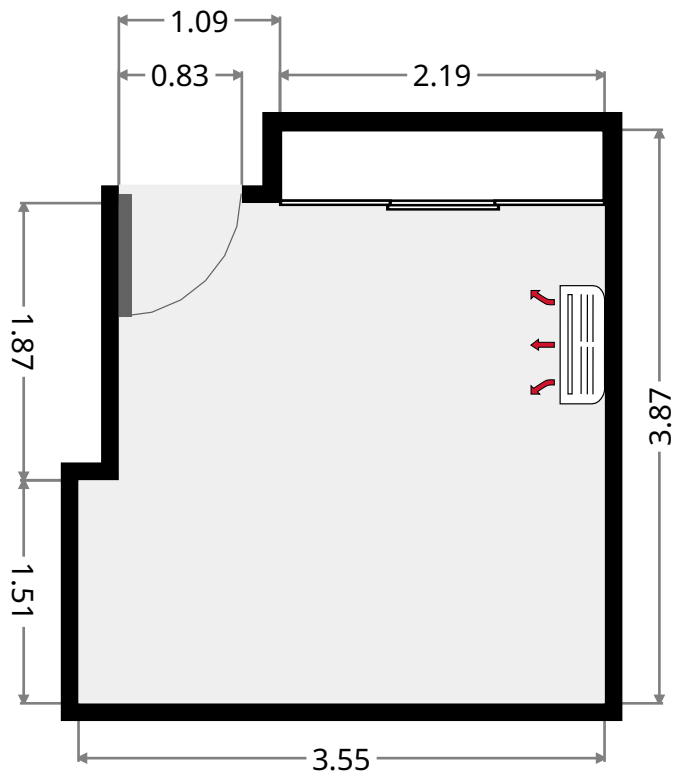
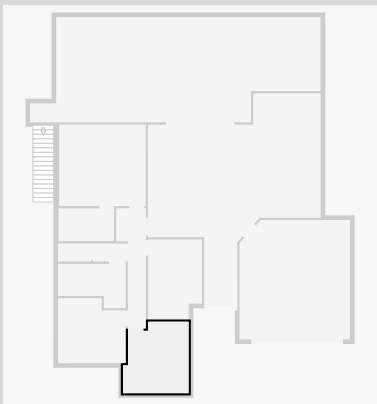

THIS FLOORPLAN IS PROVIDED WITHOUT WARRANTY OF ANY KIND. SENSOPIA DISCLAIMS ANY WARRANTY INCLUDING, WITHOUT LIMITATION, SATISFACTORY QUALITY OR ACCURACY OF DIMENSIONS.

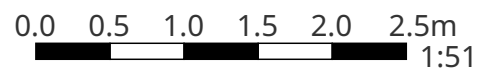

# 16 Neill Street

## Bedroom

Width: 3.52 m  
 Length: 3.67 m  
 Area: 12.04 m<sup>2</sup>  
 Perimeter: 14.37 m

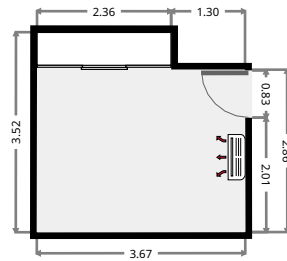
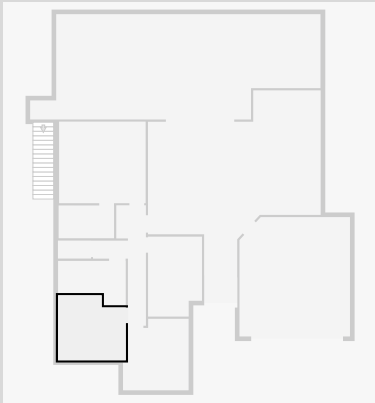

## Deck

Width: 5.70 m  
 Length: 15.72 m  
 Area: 76.60 m<sup>2</sup>  
 Perimeter: 42.83 m

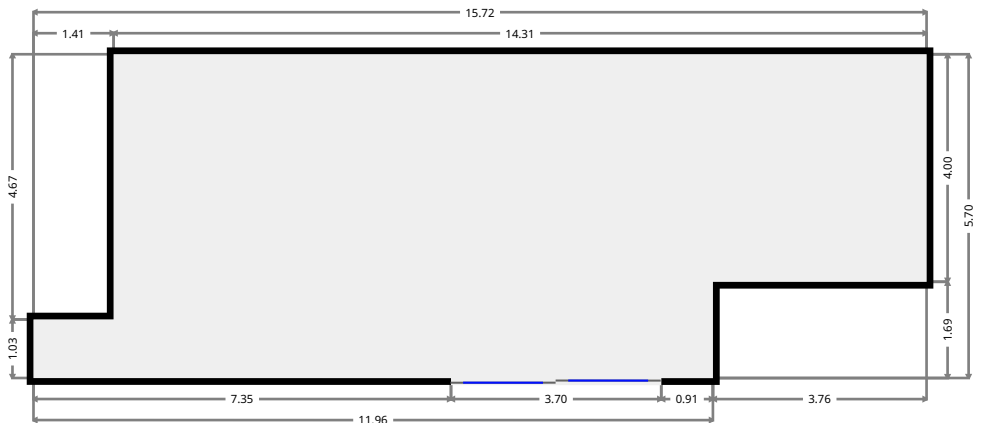
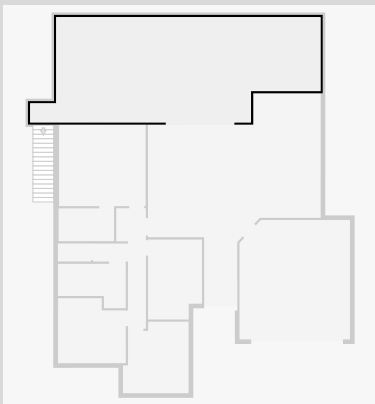

# 16 Neill Street

•  
 Width: 1.26 m  
 Length: 1.80 m  
 Area: 2.26 m<sup>2</sup>  
 Perimeter: 6.11 m

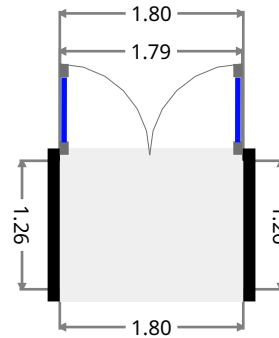
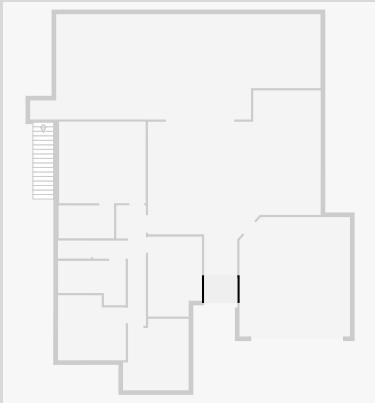

## Garage

Width: 5.98 m  
 Length: 6.46 m  
 Area: 37.92 m<sup>2</sup>  
 Perimeter: 24.18 m

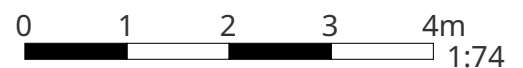
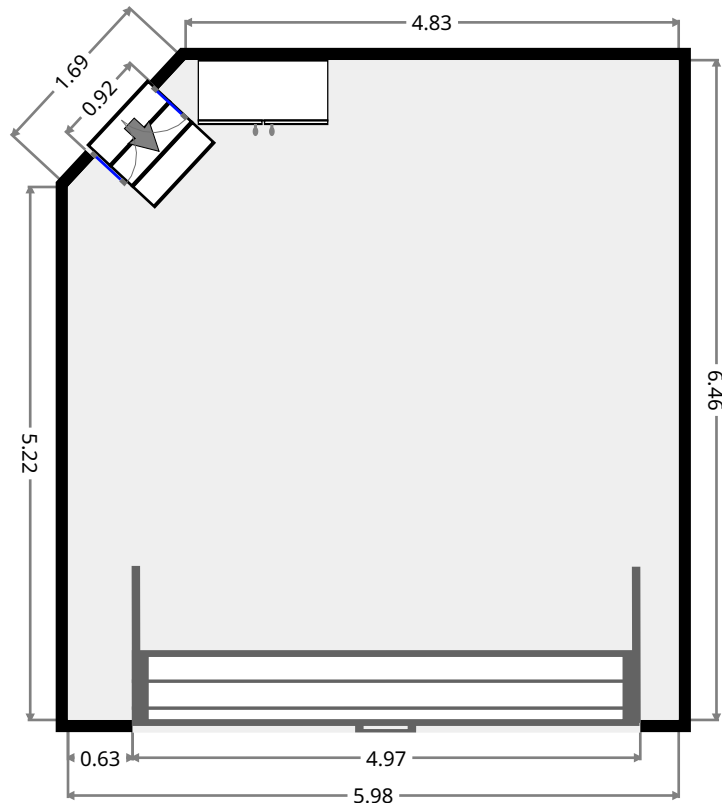
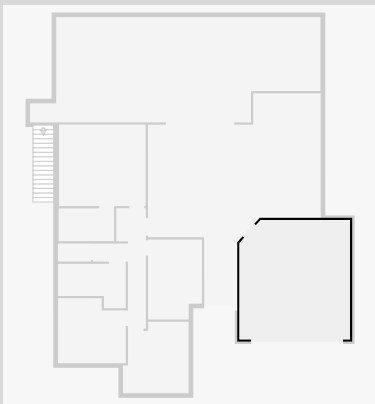

THIS FLOORPLAN IS PROVIDED WITHOUT WARRANTY OF ANY KIND. SENSOPIA DISCLAIMS ANY WARRANTY INCLUDING, WITHOUT LIMITATION, SATISFACTORY QUALITY OR ACCURACY OF DIMENSIONS.