

16 Jard Street

Created on
2021-03-31

Floors
1

▼ Ground Floor

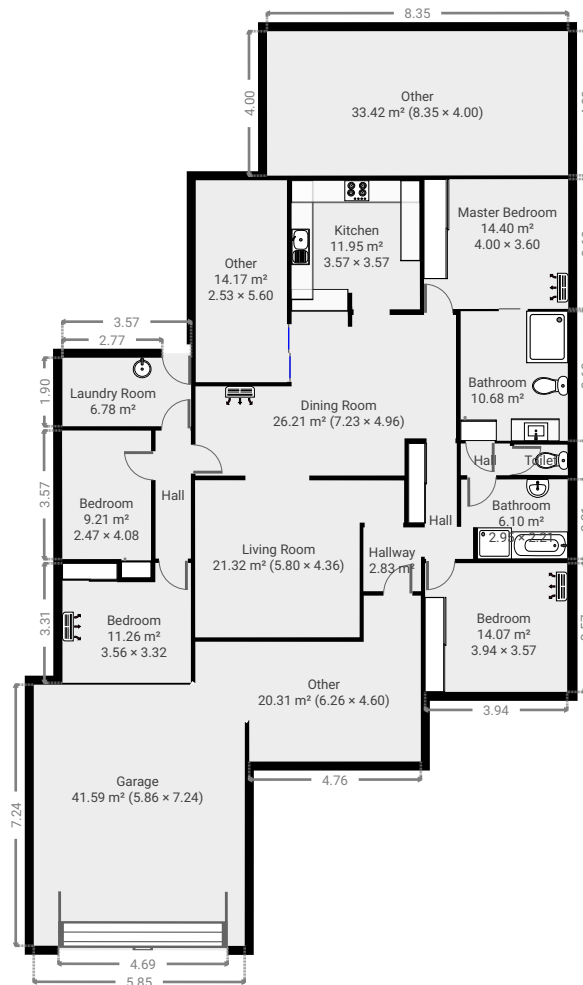
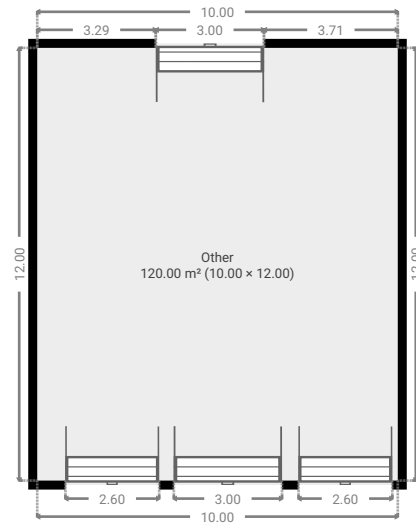

▼ Toilet
Ground Floor

WIDTH: 1.50 m • LENGTH: 0.85 m
AREA: 1.25 m² • PERIMETER: 4.65 m

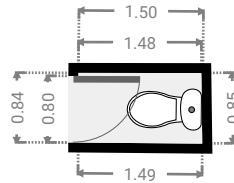
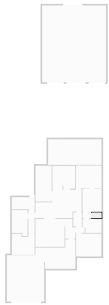

▼ Garage
Ground Floor

WIDTH: 5.86 m • LENGTH: 7.24 m
AREA: 41.59 m² • PERIMETER: 25.47 m

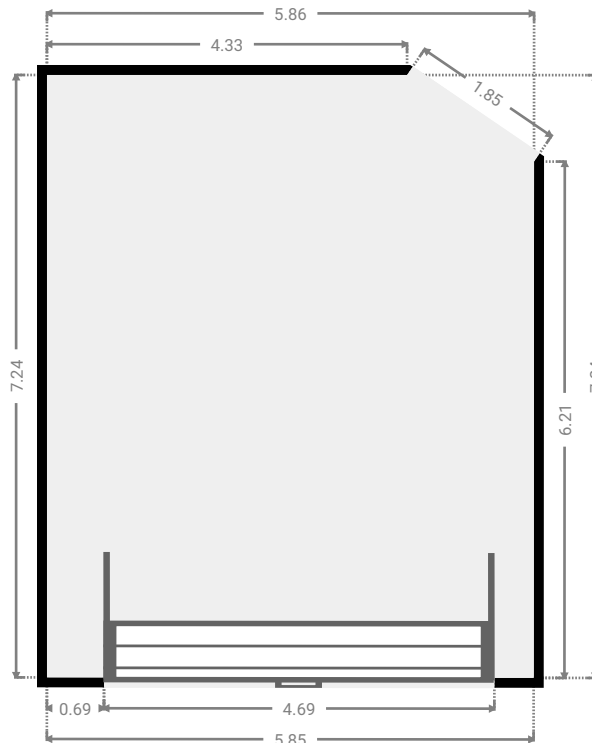

▼ Other
Ground Floor

WIDTH: 6.26 m • LENGTH: 4.60 m
AREA: 20.31 m² • PERIMETER: 21.02 m

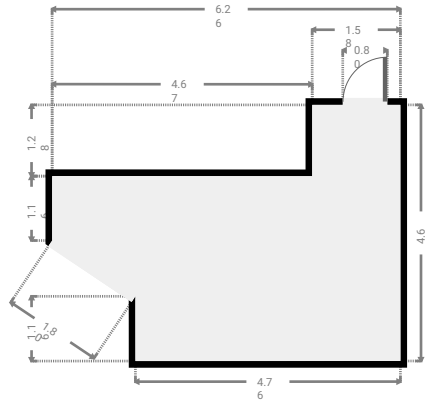
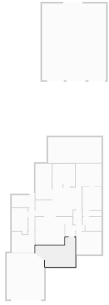

▼ Other
Ground Floor

WIDTH: 10.00 m • LENGTH: 12.00 m
AREA: 120.00 m² • PERIMETER: 44.00 m

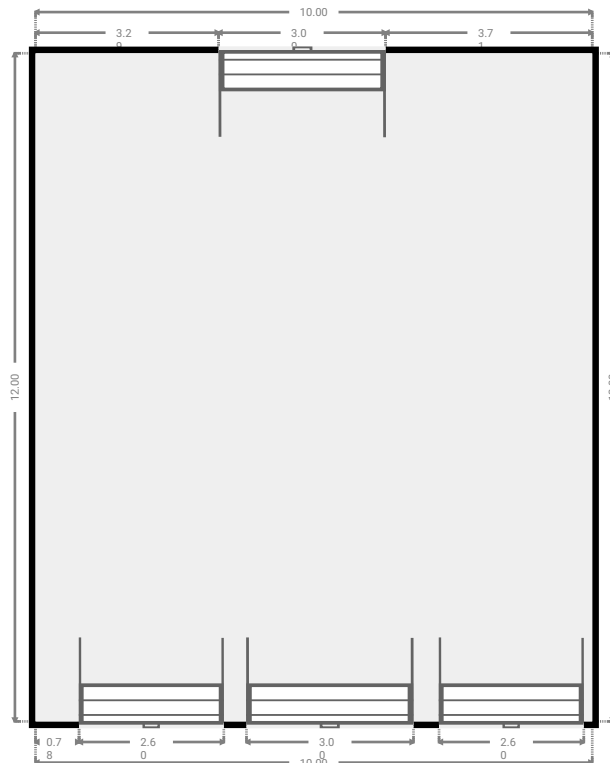

▼ Other
Ground Floor

WIDTH: 8.35 m • LENGTH: 4.00 m
AREA: 33.42 m² • PERIMETER: 24.70 m

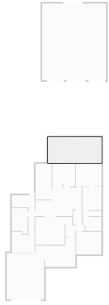

▼ Other
Ground Floor

WIDTH: 2.53 m • LENGTH: 5.60 m
AREA: 14.17 m² • PERIMETER: 16.26 m

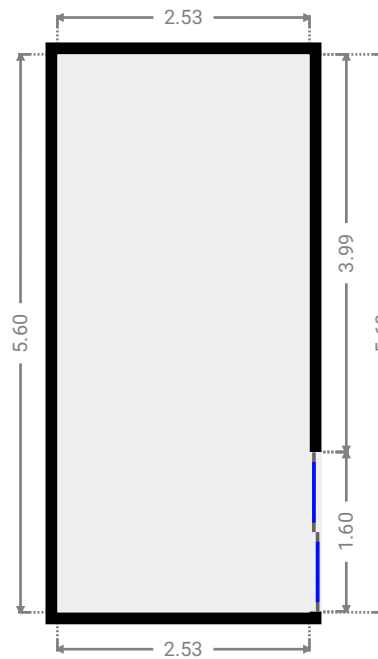
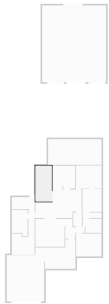

▼ **Bedroom**
Ground Floor

WIDTH: 3.56 m • LENGTH: 3.32 m
AREA: 11.26 m² • PERIMETER: 14.82 m

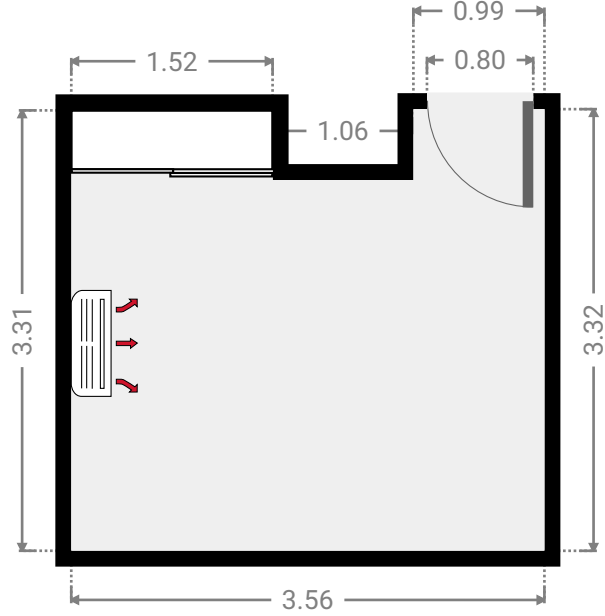

▼ **Bedroom**
Ground Floor

WIDTH: 2.47 m • LENGTH: 4.08 m
AREA: 9.21 m² • PERIMETER: 13.10 m

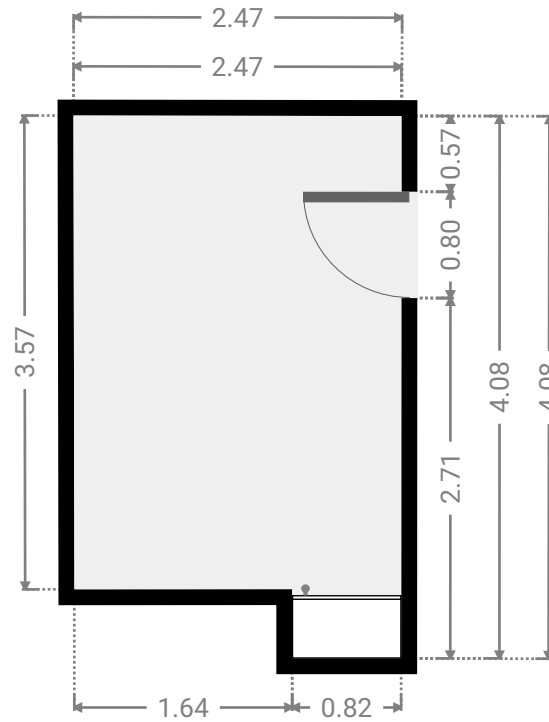

▼ **Laundry Room**
Ground Floor

WIDTH: 3.57 m • LENGTH: 1.90 m
AREA: 6.78 m² • PERIMETER: 10.94 m

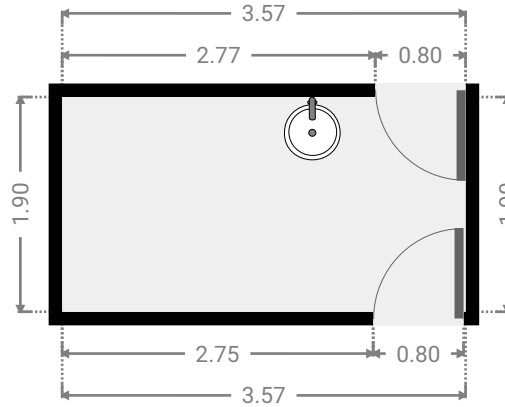

▼ **Hall**
Ground Floor

WIDTH: 0.98 m • LENGTH: 3.55 m
AREA: 3.48 m² • PERIMETER: 9.06 m

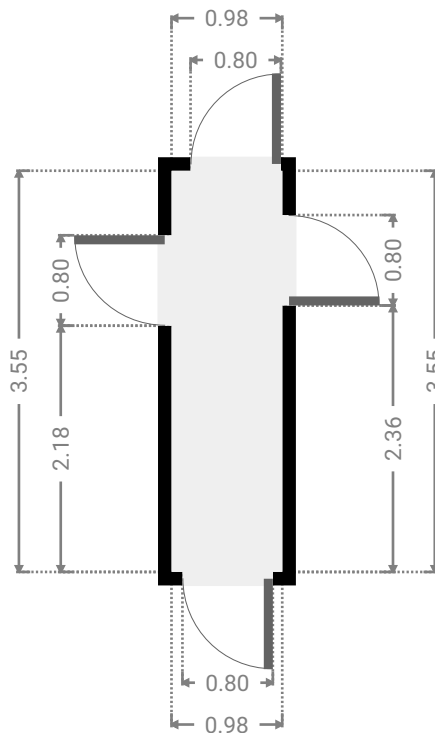

▼ **Hallway**
Ground Floor

WIDTH: 1.60 m • LENGTH: 1.77 m
AREA: 2.83 m² • PERIMETER: 6.74 m

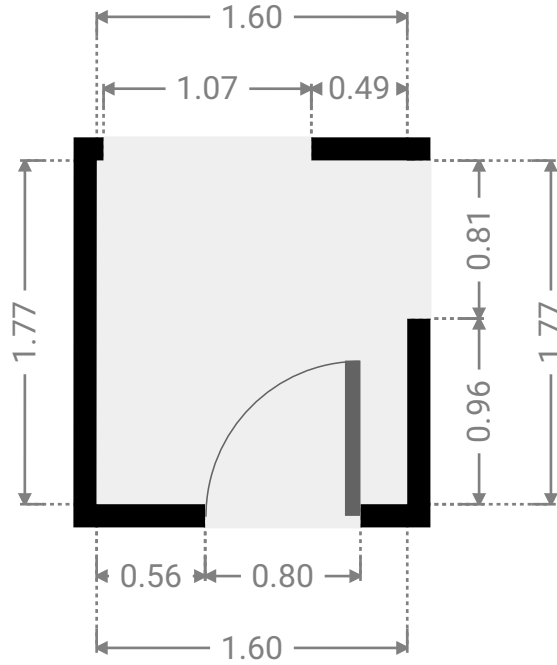
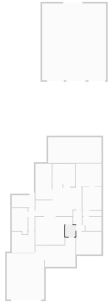

▼ **Bathroom**
Ground Floor

WIDTH: 2.95 m • LENGTH: 2.21 m
AREA: 6.10 m² • PERIMETER: 10.31 m

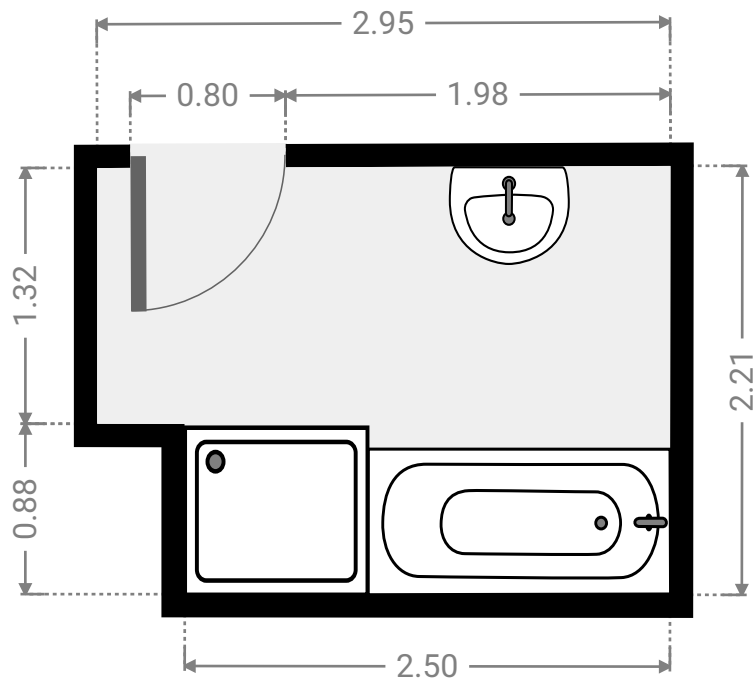

▼ **Hall**
Ground Floor

WIDTH: 1.36 m • LENGTH: 0.88 m
AREA: 1.20 m² • PERIMETER: 4.48 m

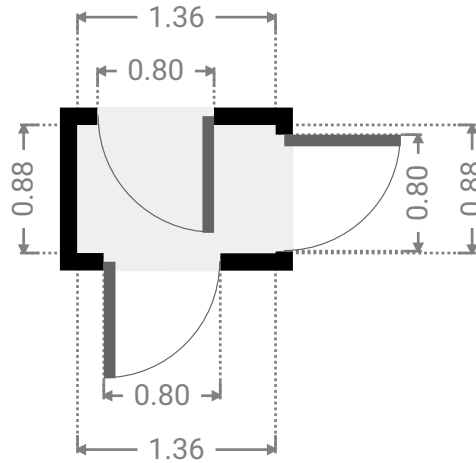

▼ **Bedroom**
Ground Floor

WIDTH: 3.94 m • LENGTH: 3.57 m
AREA: 14.07 m² • PERIMETER: 15.02 m

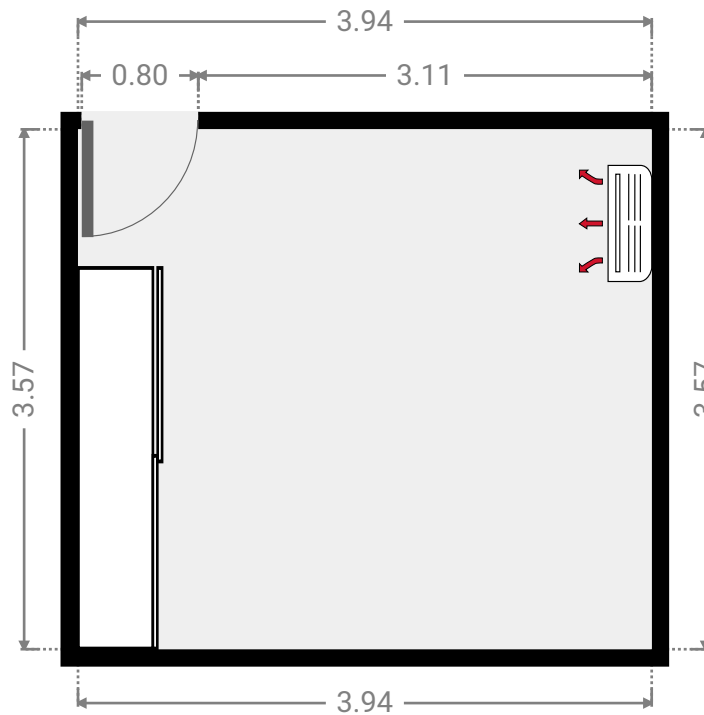
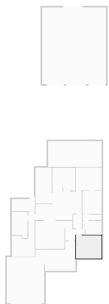

▼ Hall
Ground Floor

WIDTH: 1.79 m • LENGTH: 3.21 m
AREA: 4.24 m² • PERIMETER: 9.99 m

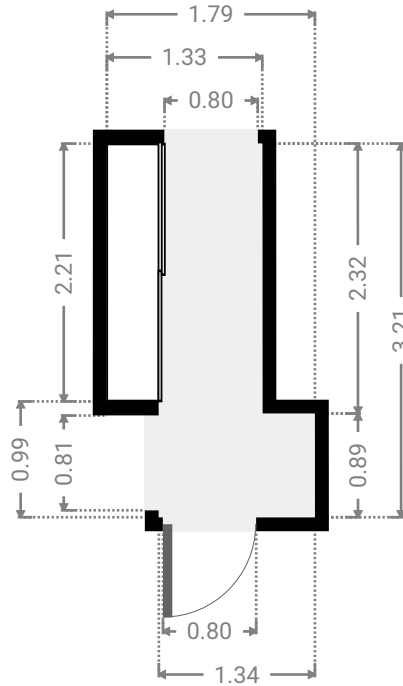
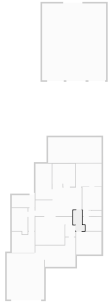

▼ Bathroom
Ground Floor

WIDTH: 2.98 m • LENGTH: 3.60 m
AREA: 10.68 m² • PERIMETER: 13.13 m

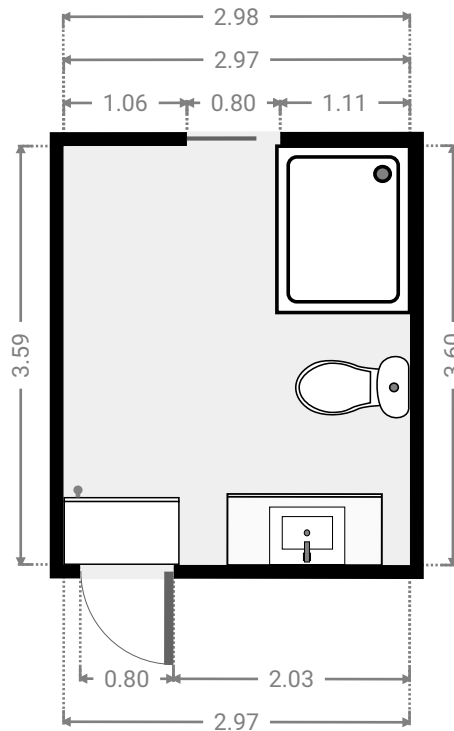
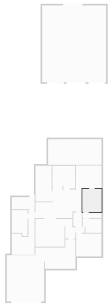

▼ **Master Bedroom**
Ground Floor

WIDTH: 4.00 m • LENGTH: 3.60 m
AREA: 14.40 m² • PERIMETER: 15.20 m

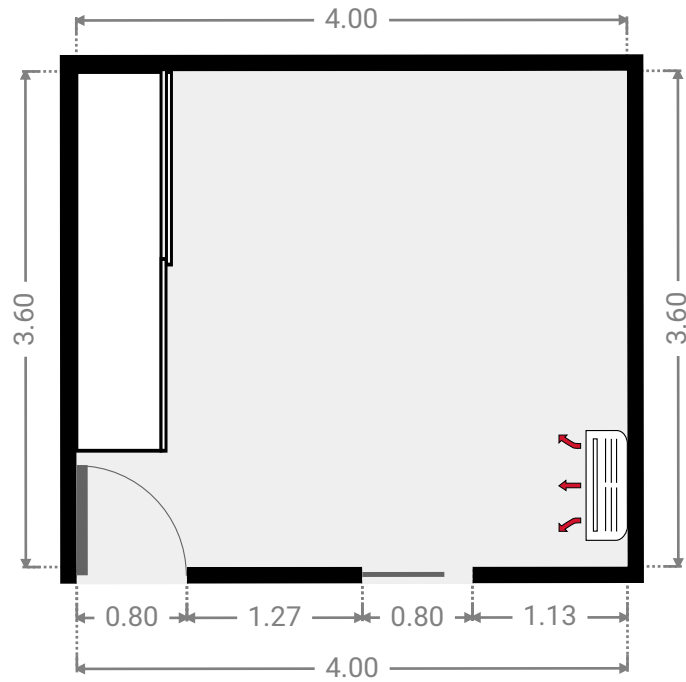

▼ **Kitchen**
Ground Floor

WIDTH: 3.57 m • LENGTH: 3.57 m
AREA: 11.95 m² • PERIMETER: 14.27 m

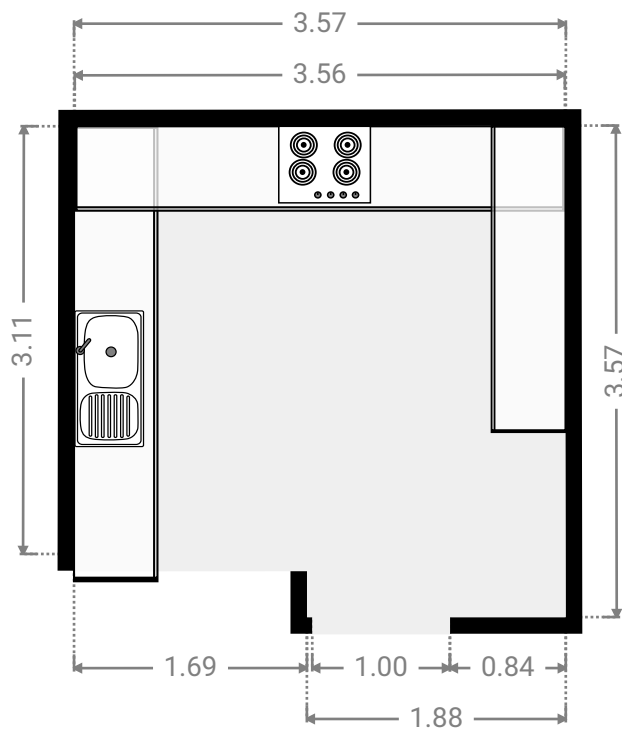
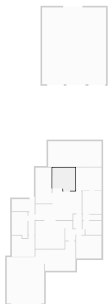

▼ Dining Room
Ground Floor

WIDTH: 7.23 m • LENGTH: 4.96 m
AREA: 26.21 m² • PERIMETER: 24.36 m

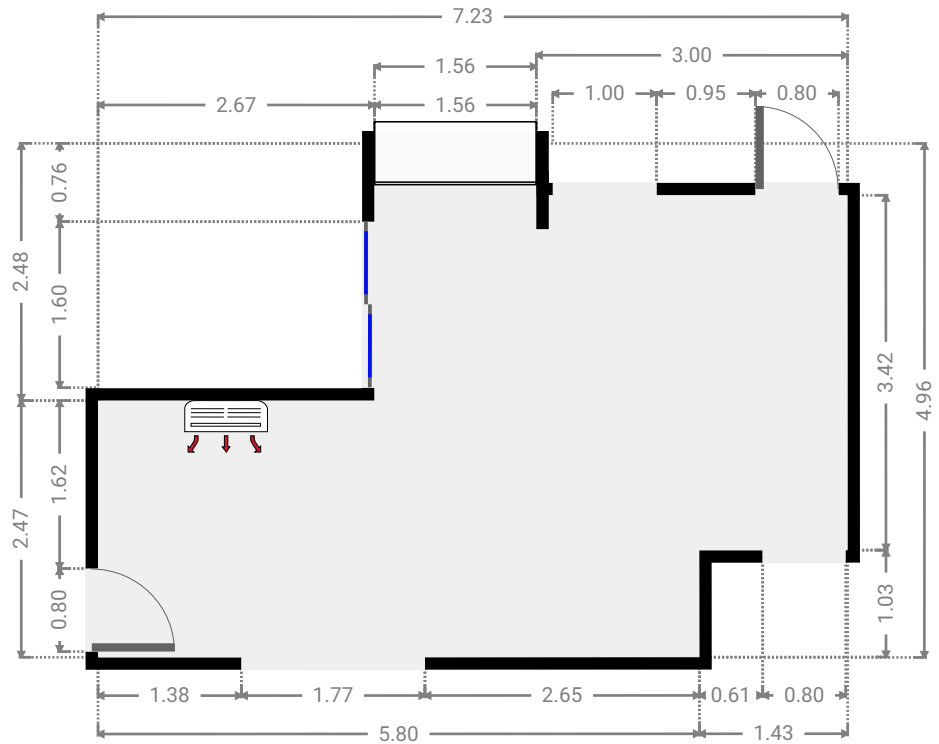
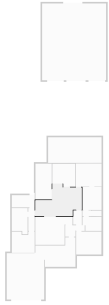

▼ Living Room
Ground Floor

WIDTH: 5.80 m • LENGTH: 4.36 m
AREA: 21.32 m² • PERIMETER: 20.30 m

