

16 Corrella Drive

SUBMITTED BY

Ray White Rockhampton Casey
stockers@cqoz.com

CREATED ON

2022-06-29

Floors

1

▼ Ground Floor

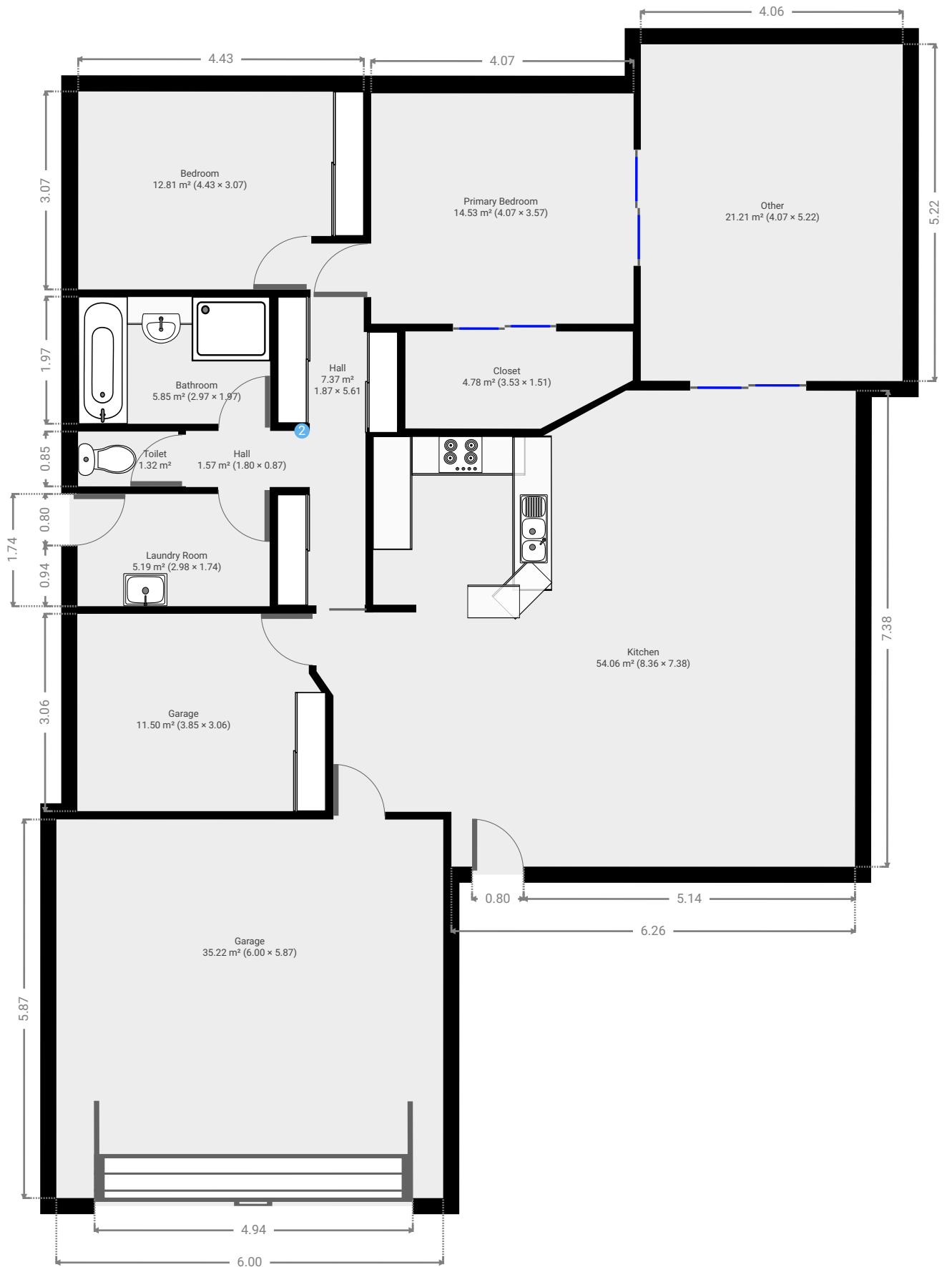

▼ **Bathroom**
Ground Floor

WIDTH: 2.97 m • LENGTH: 1.97 m
AREA: 5.85 m² • PERIMETER: 9.88 m

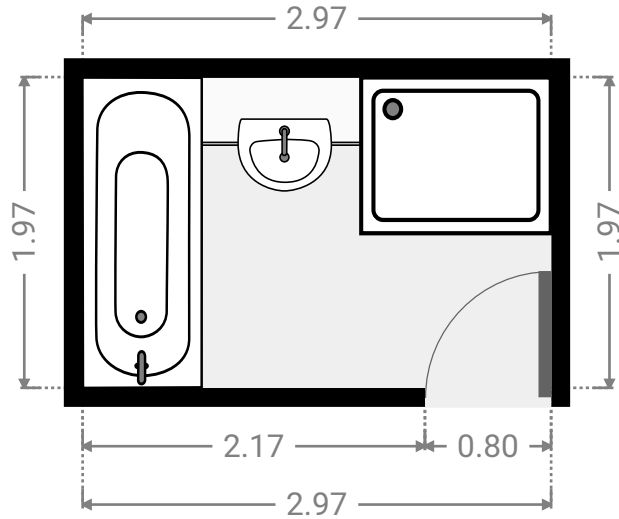
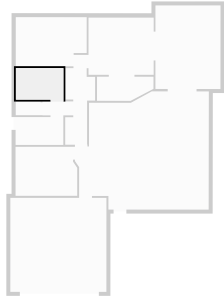

▼ **Bedroom**
Ground Floor

WIDTH: 4.43 m • LENGTH: 3.07 m
AREA: 12.81 m² • PERIMETER: 15.00 m

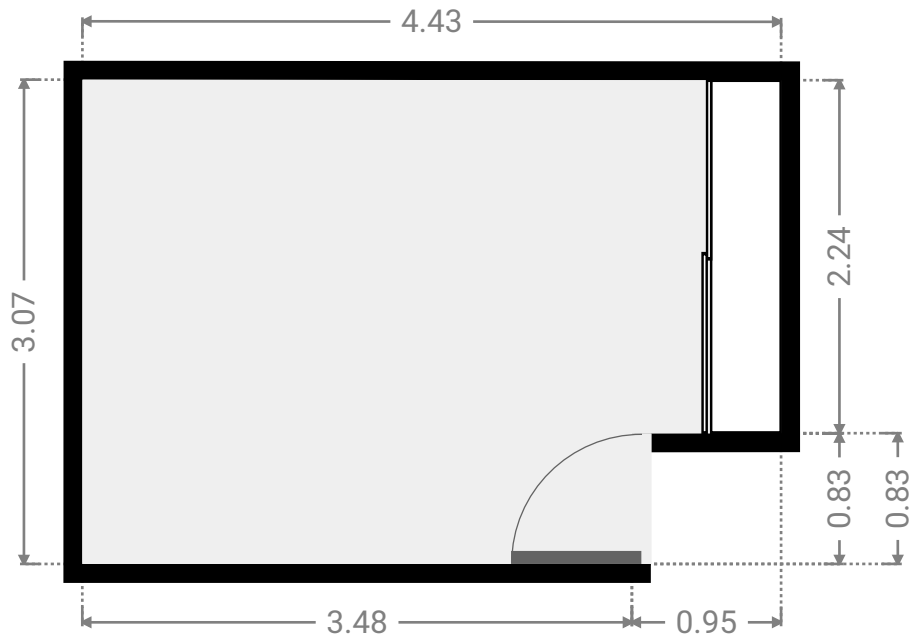
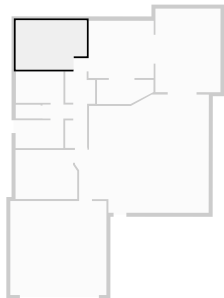

FLOORS: 1

▼ **Garage**
Ground Floor

WIDTH: 6.00 m • LENGTH: 5.87 m
AREA: 35.22 m² • PERIMETER: 23.74 m

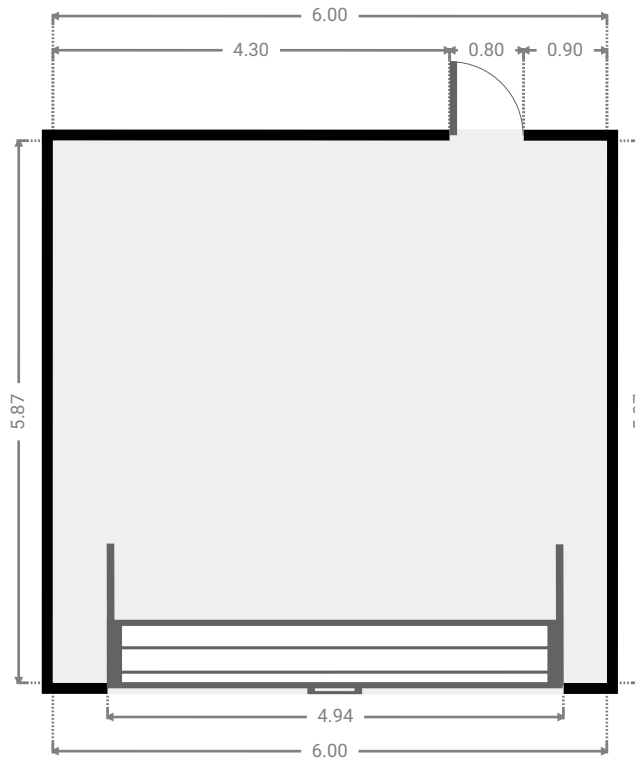
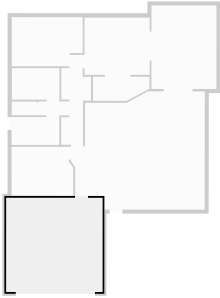

▼ **Garage**
Ground Floor

WIDTH: 3.85 m • LENGTH: 3.06 m
AREA: 11.50 m² • PERIMETER: 13.64 m

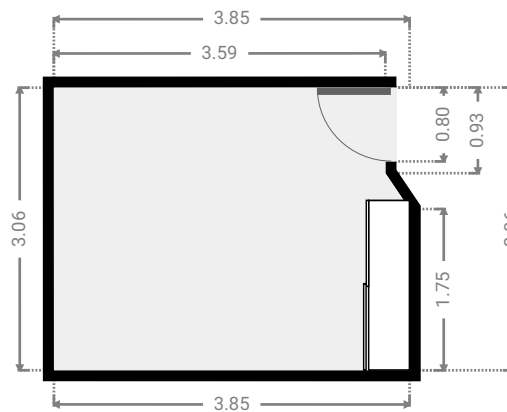
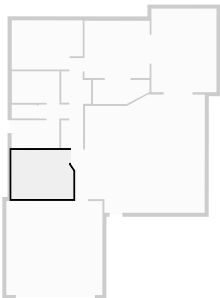

▼ Hall
Ground Floor

WIDTH: 1.87 m • LENGTH: 5.61 m
AREA: 7.37 m² • PERIMETER: 15.94 m

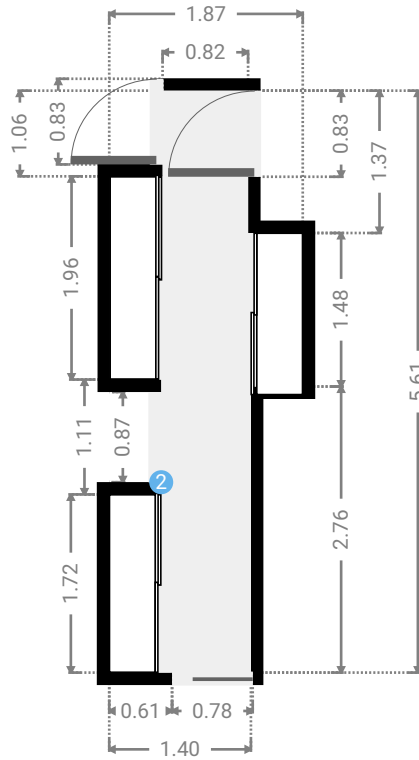
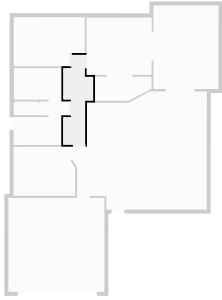

▼ Hall
Ground Floor

WIDTH: 1.80 m • LENGTH: 0.87 m
AREA: 1.57 m² • PERIMETER: 5.34 m

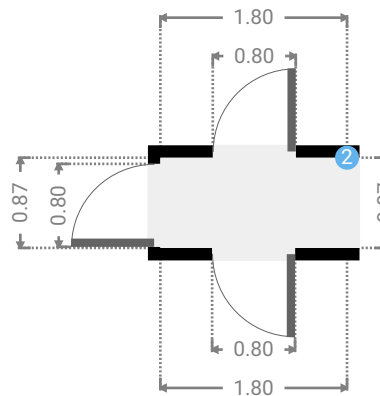
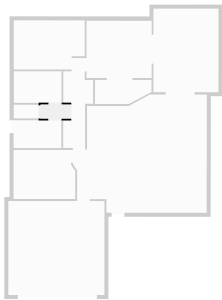

▼ **Hall**/Ground Floor

2 **OPENING**

Height
0.00 m



▼ **Kitchen**
Ground Floor

WIDTH: 8.36 m • LENGTH: 7.38 m
AREA: 54.06 m² • PERIMETER: 30.77 m

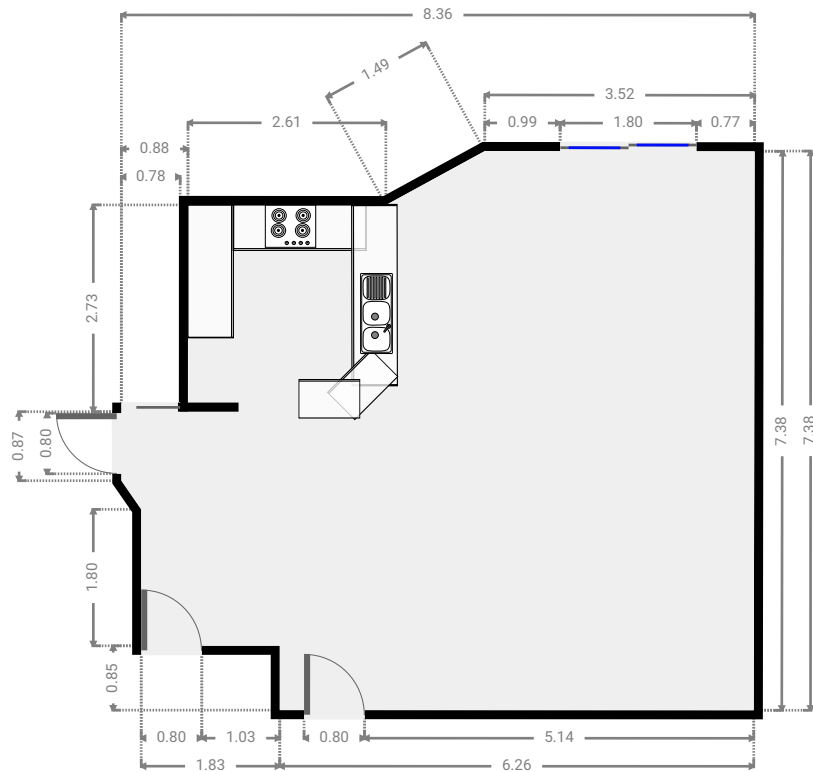
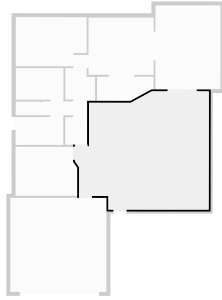

▼ **Laundry Room**
Ground Floor

WIDTH: 2.98 m • LENGTH: 1.74 m
AREA: 5.19 m² • PERIMETER: 9.44 m

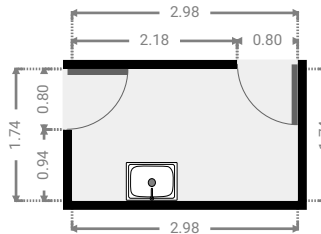
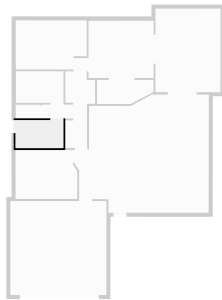

FLOORS: 1

▼ **Other**
Ground Floor

WIDTH: 4.07 m • LENGTH: 5.22 m
AREA: 21.21 m² • PERIMETER: 18.57 m

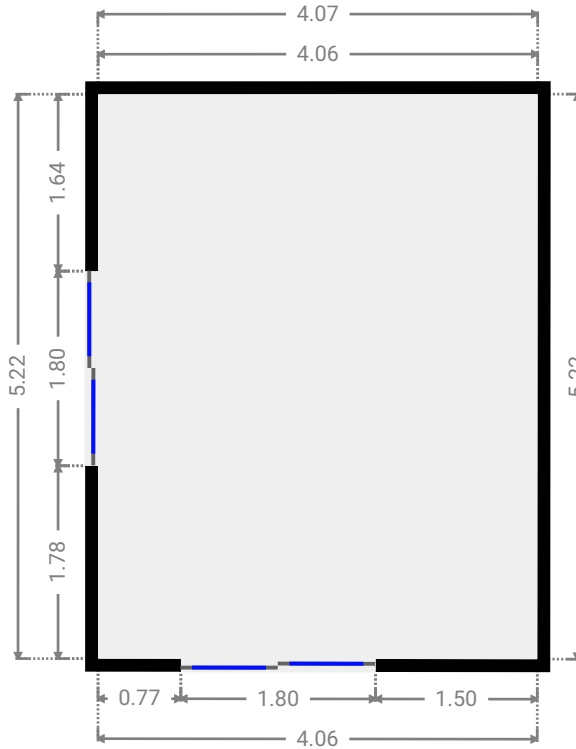
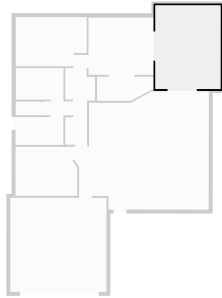

▼ **Primary Bedroom**
Ground Floor

WIDTH: 4.07 m • LENGTH: 3.57 m
AREA: 14.53 m² • PERIMETER: 15.28 m

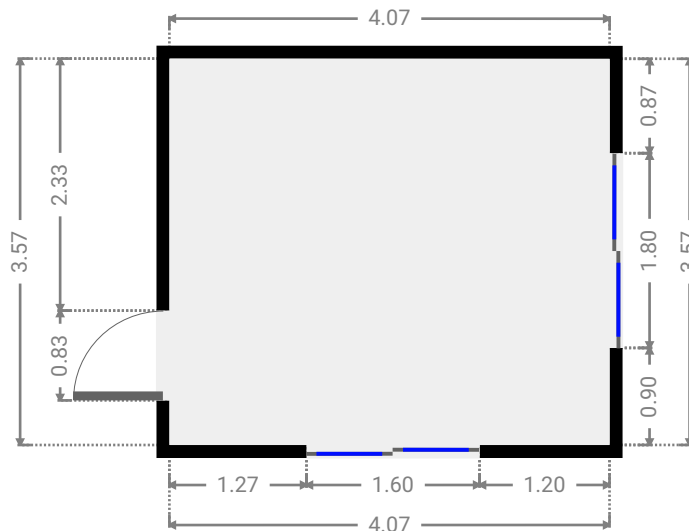
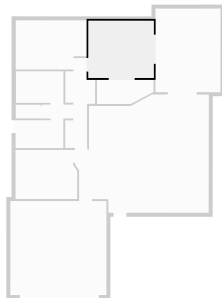

FLOORS: 1

▼ Closet
Ground Floor

WIDTH: 3.53 m • LENGTH: 1.51 m
AREA: 4.78 m² • PERIMETER: 9.50 m

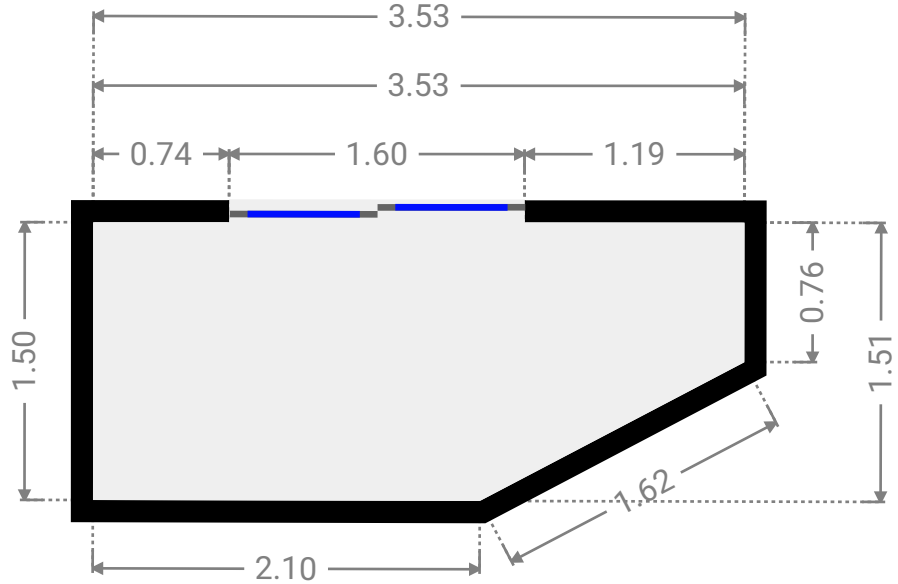
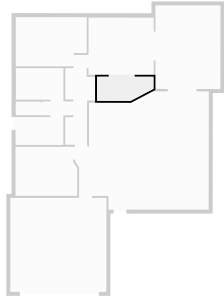

▼ Toilet
Ground Floor

WIDTH: 1.55 m • LENGTH: 0.85 m
AREA: 1.32 m² • PERIMETER: 4.81 m

