

# 152 Lioncreek Road

**SUBMITTED BY**

Ray White Rockhampton Casey  
stockers@cqoz.com

---

**CREATED ON**

2022-02-24

---

**Floors**

2

---

▼ Ground Floor

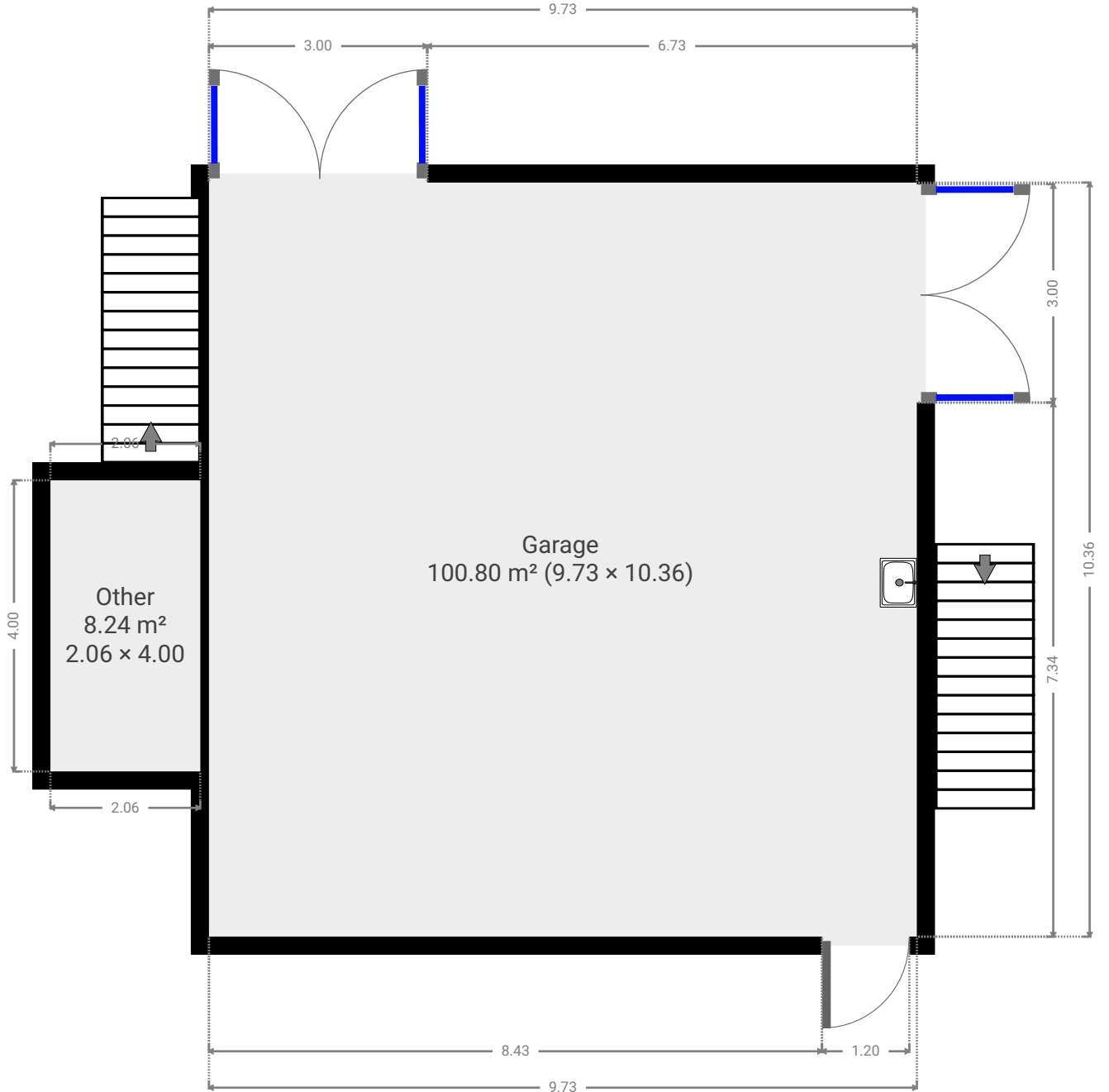

FLOORS: 2

▼ **Garage**  
Ground Floor

WIDTH: 10.36 m • LENGTH: 9.73 m  
AREA: 100.80 m<sup>2</sup> • PERIMETER: 40.18 m

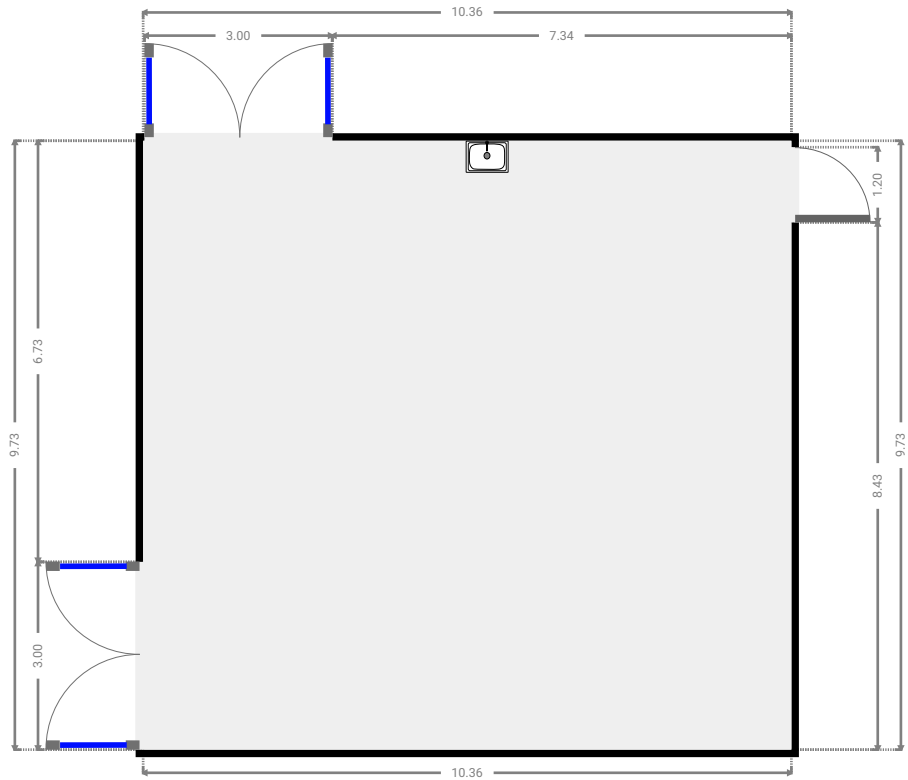
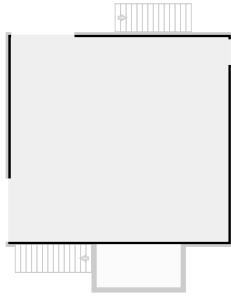

▼ **Other**  
Ground Floor

WIDTH: 4.00 m • LENGTH: 2.06 m  
AREA: 8.24 m<sup>2</sup> • PERIMETER: 12.12 m

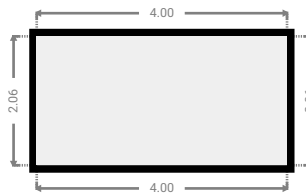
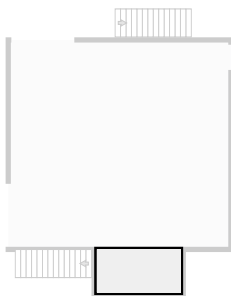

▼ 1st Floor

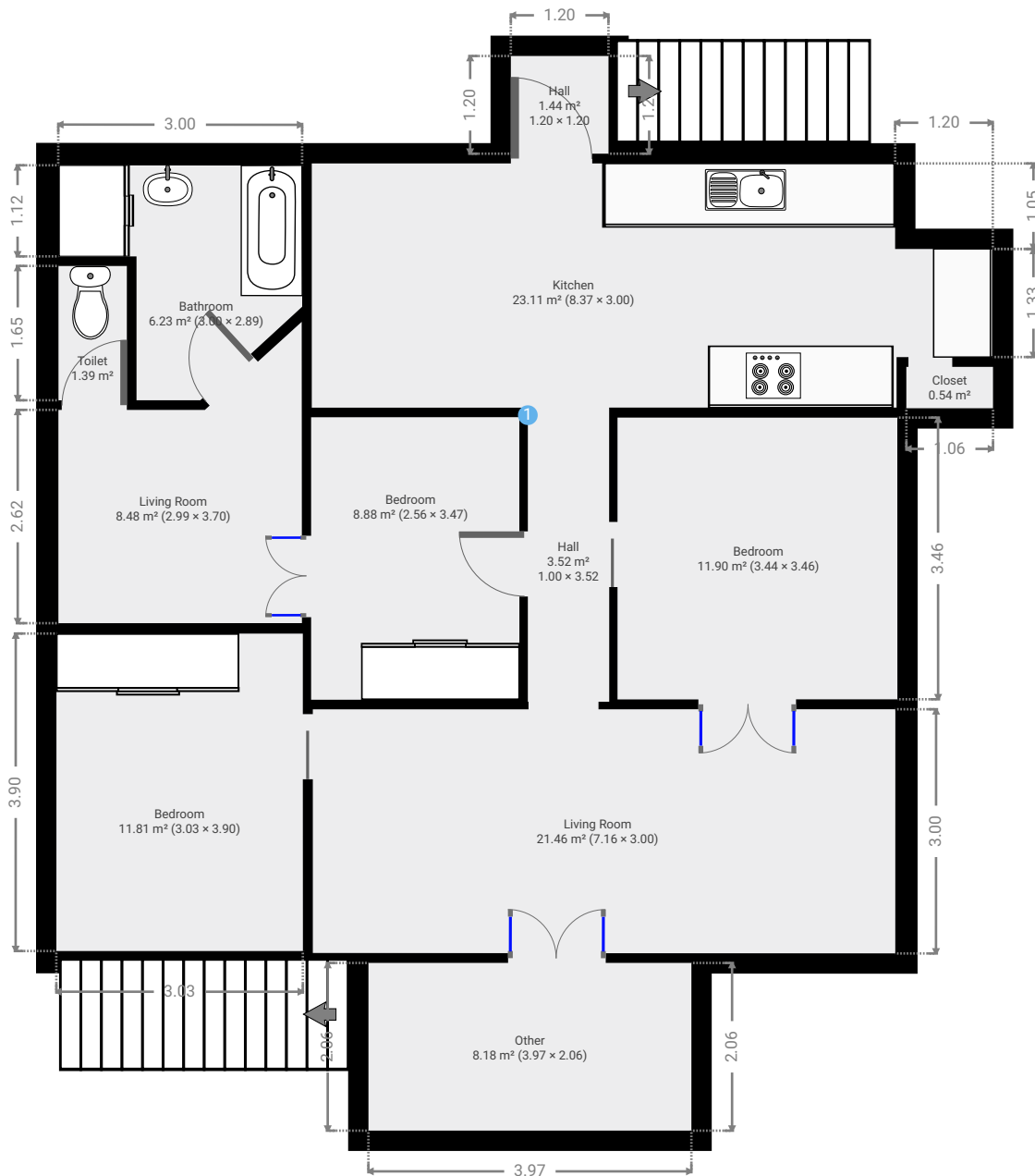

▼ Living Room  
1st Floor

WIDTH: 7.16 m • LENGTH: 3.00 m  
AREA: 21.46 m<sup>2</sup> • PERIMETER: 20.32 m

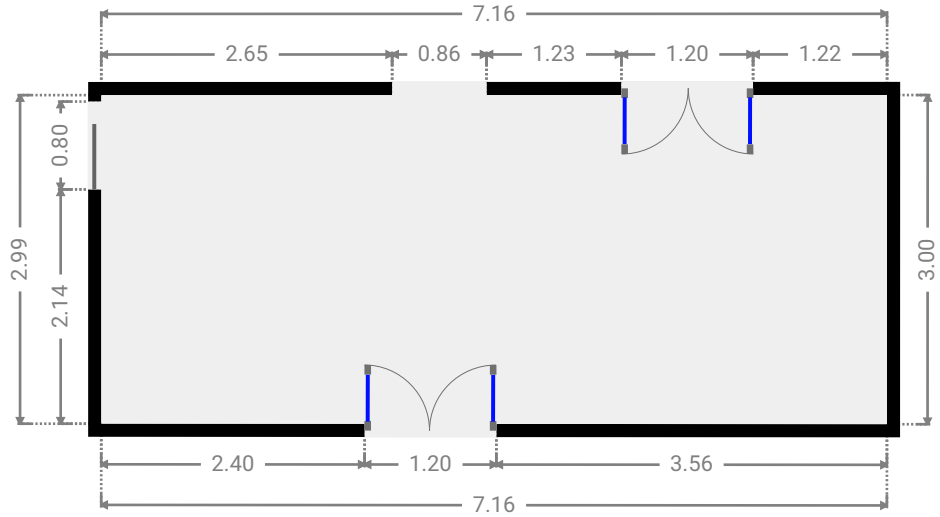
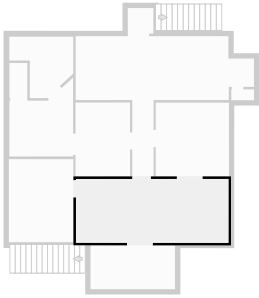

▼ Bedroom  
1st Floor

WIDTH: 3.44 m • LENGTH: 3.46 m  
AREA: 11.90 m<sup>2</sup> • PERIMETER: 13.80 m

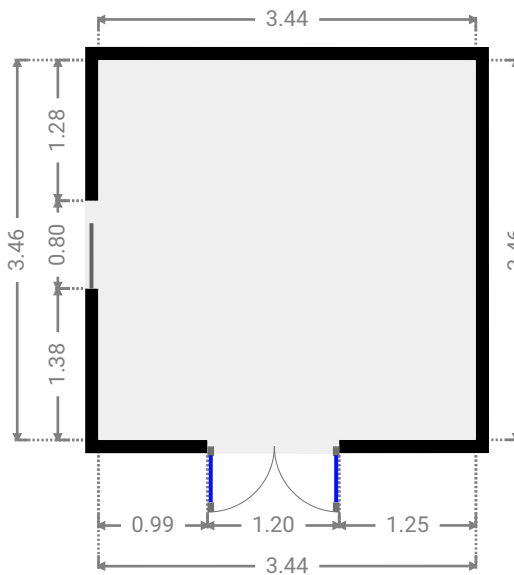
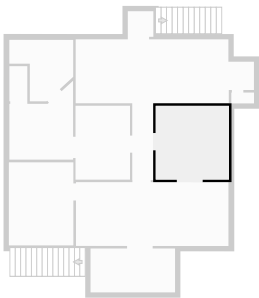

▼ **Hall**  
1st Floor

WIDTH: 1.00 m • LENGTH: 3.52 m  
AREA: 3.52 m<sup>2</sup> • PERIMETER: 9.04 m

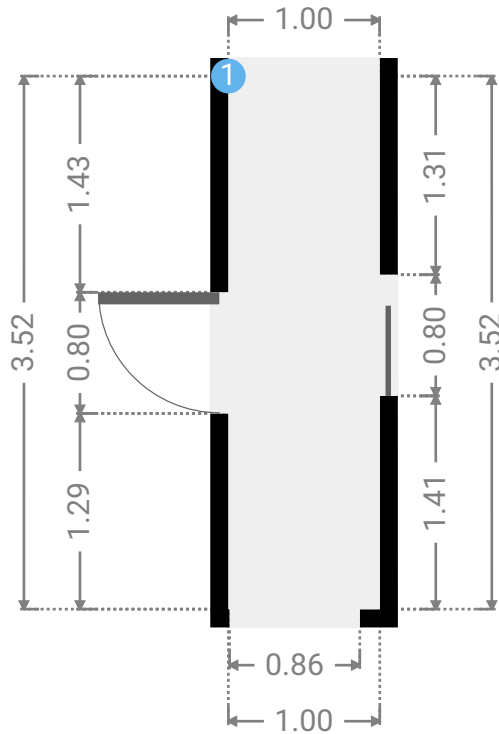
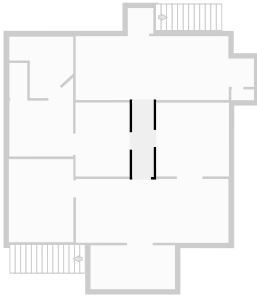

▼ **Hall/1st Floor**

**1** OPENING

Height  
0.00 m



▼ **Bedroom**  
1st Floor

WIDTH: 3.03 m • LENGTH: 3.90 m  
AREA: 11.81 m<sup>2</sup> • PERIMETER: 13.86 m

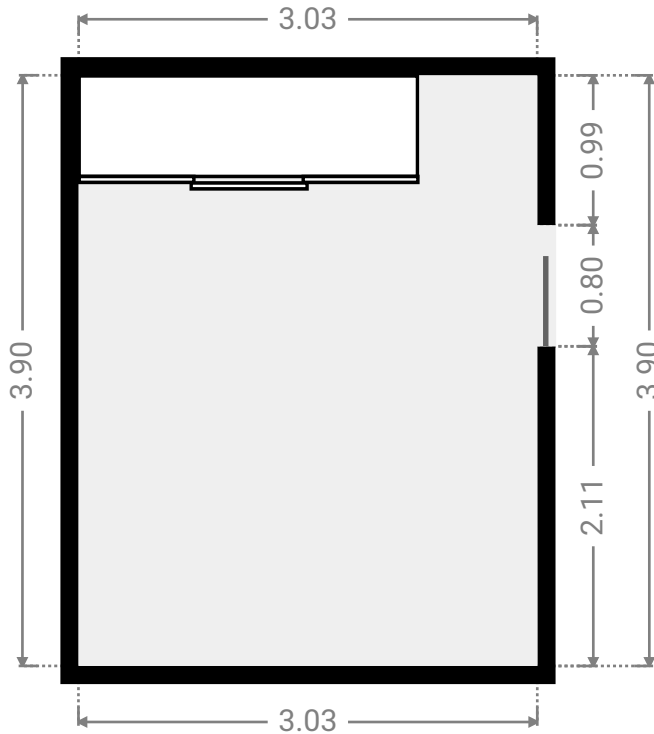
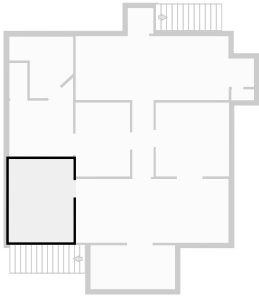

▼ **Bedroom**  
1st Floor

WIDTH: 2.56 m • LENGTH: 3.47 m  
AREA: 8.88 m<sup>2</sup> • PERIMETER: 12.06 m

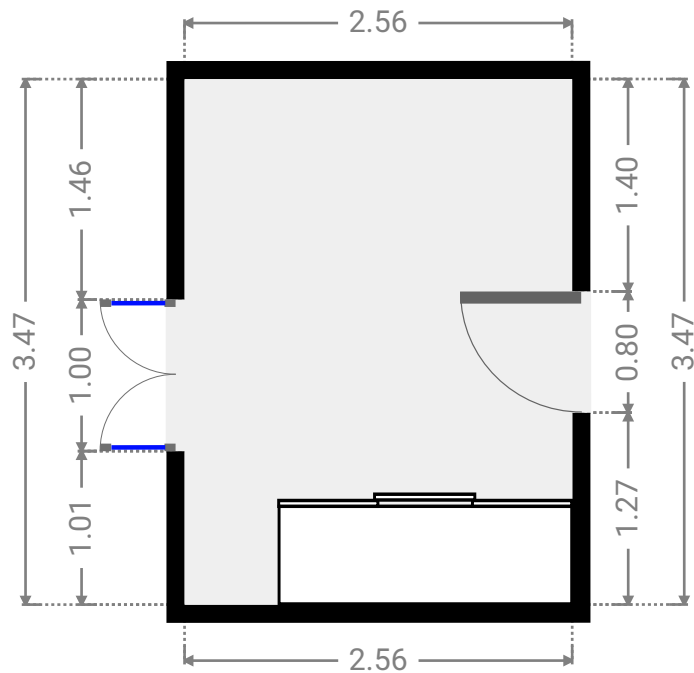
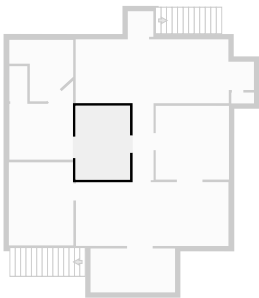

▼ **Living Room**  
1st Floor

WIDTH: 2.99 m • LENGTH: 3.70 m  
AREA: 8.48 m<sup>2</sup> • PERIMETER: 12.72 m

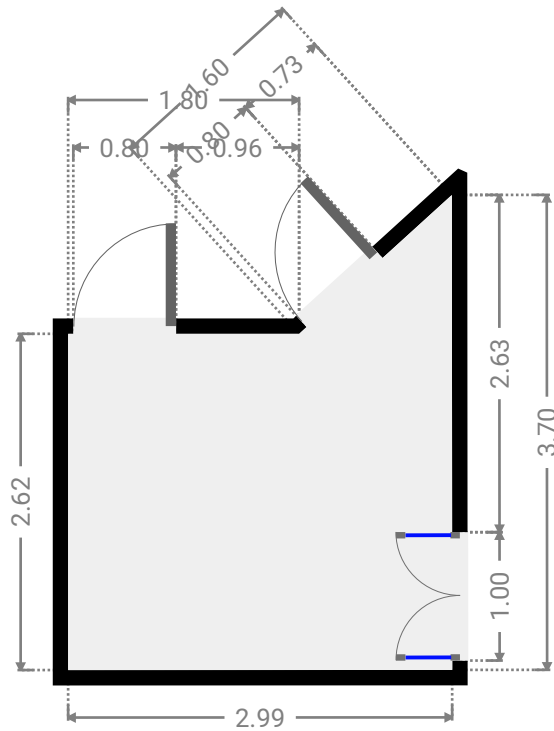
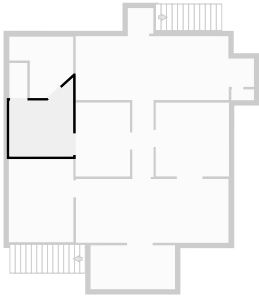

▼ **Toilet**  
1st Floor

WIDTH: 0.84 m • LENGTH: 1.65 m  
AREA: 1.39 m<sup>2</sup> • PERIMETER: 4.98 m

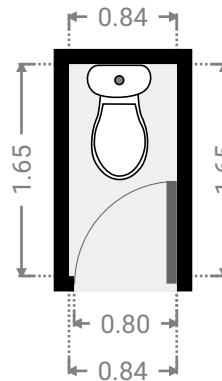
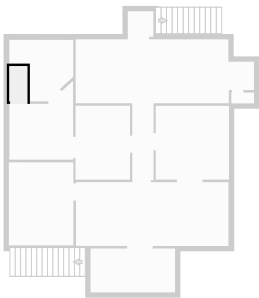



▼ Bathroom  
1st Floor

WIDTH: 3.00 m • LENGTH: 2.89 m  
AREA: 6.23 m<sup>2</sup> • PERIMETER: 11.06 m

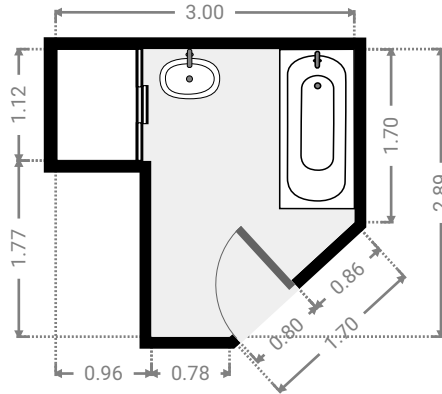
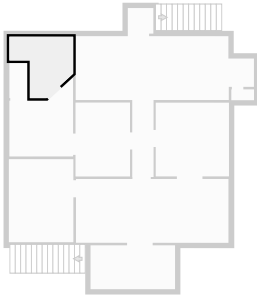

▼ Kitchen  
1st Floor

WIDTH: 8.37 m • LENGTH: 3.00 m  
AREA: 23.11 m<sup>2</sup> • PERIMETER: 22.74 m

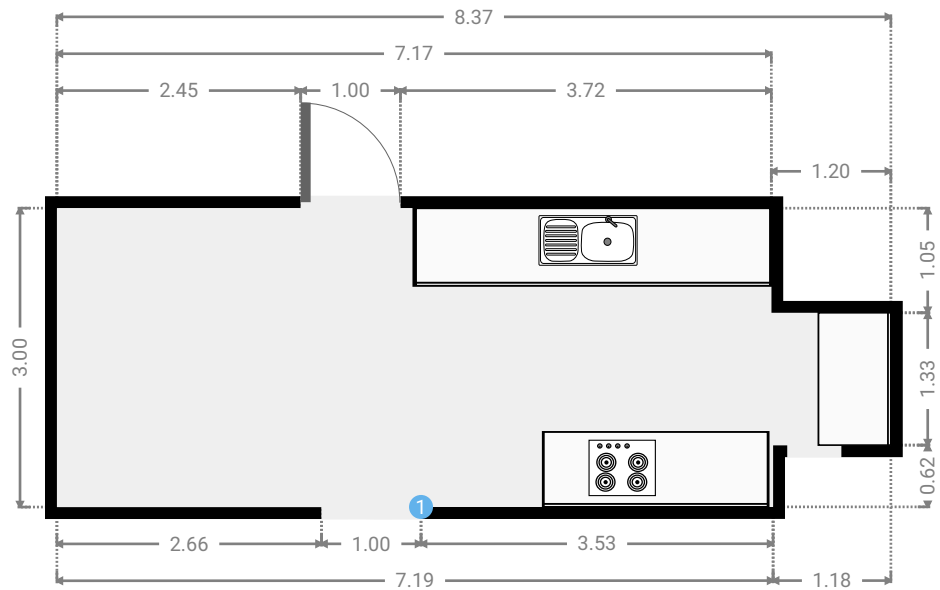
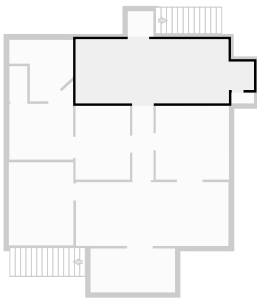

▼ Closet  
1st Floor

WIDTH: 1.06 m • LENGTH: 0.51 m  
AREA: 0.54 m<sup>2</sup> • PERIMETER: 3.15 m

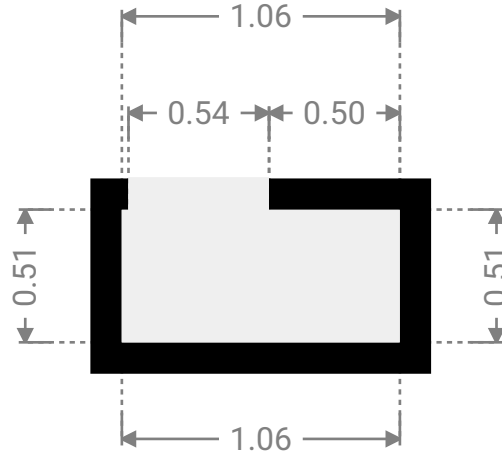
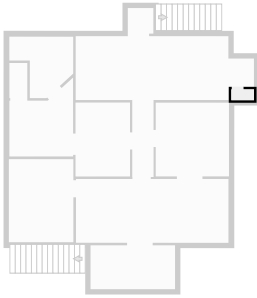

▼ Hall  
1st Floor

WIDTH: 1.20 m • LENGTH: 1.20 m  
AREA: 1.44 m<sup>2</sup> • PERIMETER: 4.80 m

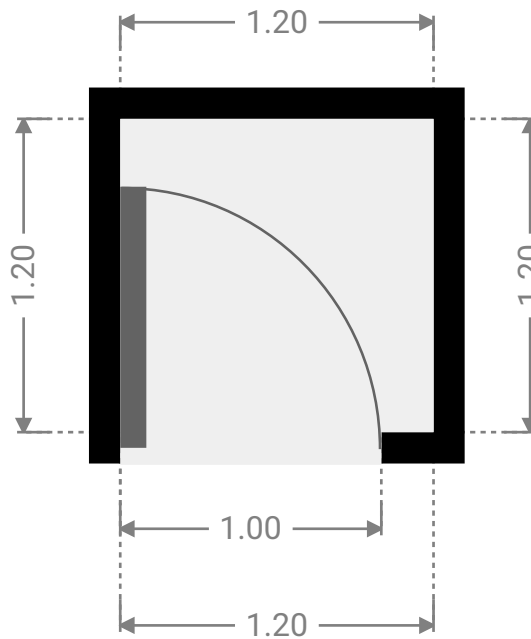
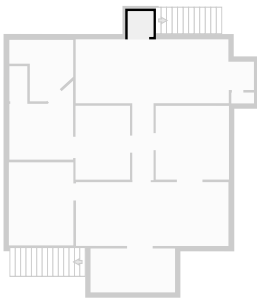

▼ Other  
1st Floor

WIDTH: 3.97 m • LENGTH: 2.06 m  
AREA: 8.18 m<sup>2</sup> • PERIMETER: 12.06 m

