

151 Earl Street

Created on
2020-04-14

Floors
2

▼ Ground Floor

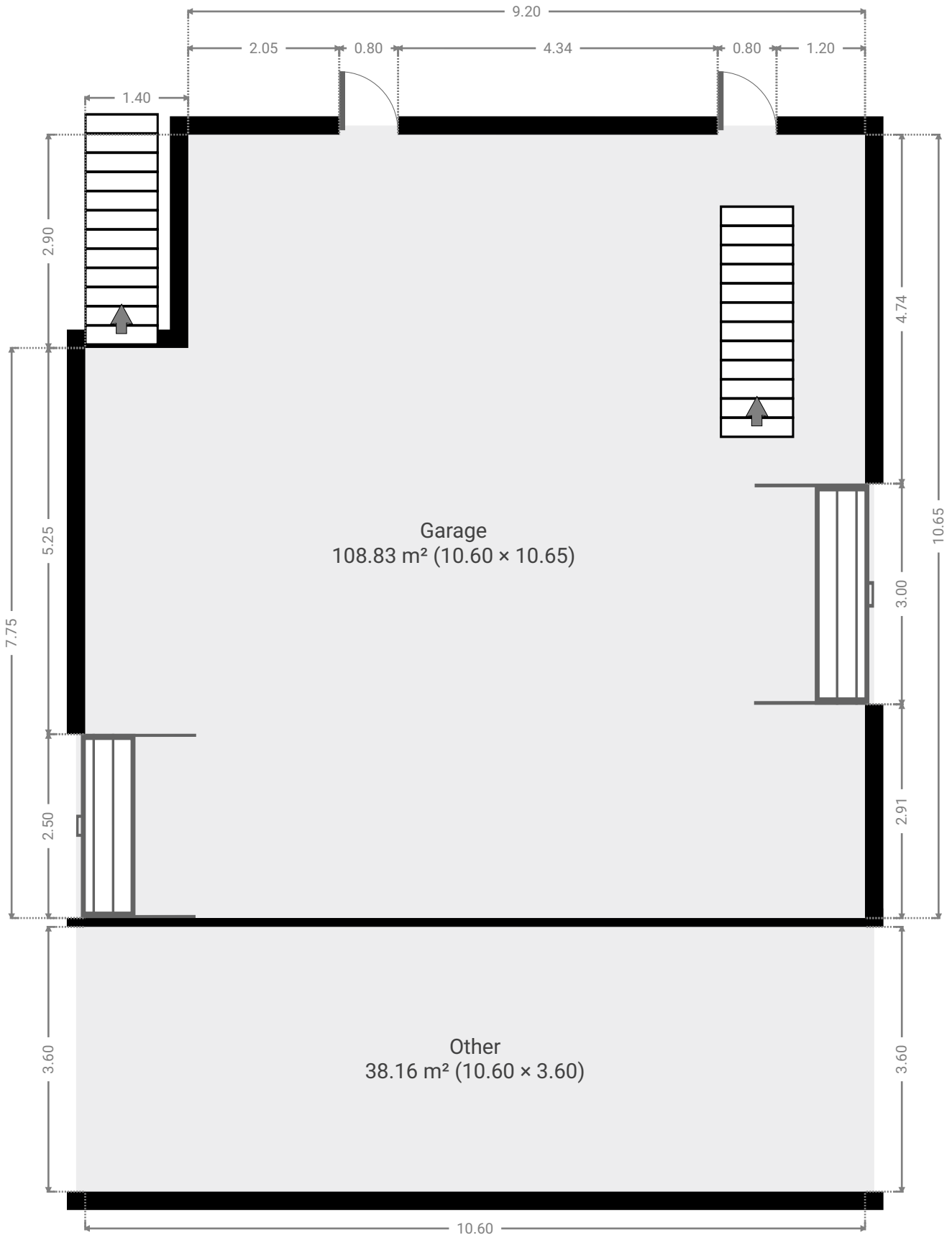

▼ **Garage**
Ground Floor

WIDTH: 10.65 m • LENGTH: 10.60 m
AREA: 108.83 m² • PERIMETER: 42.50 m

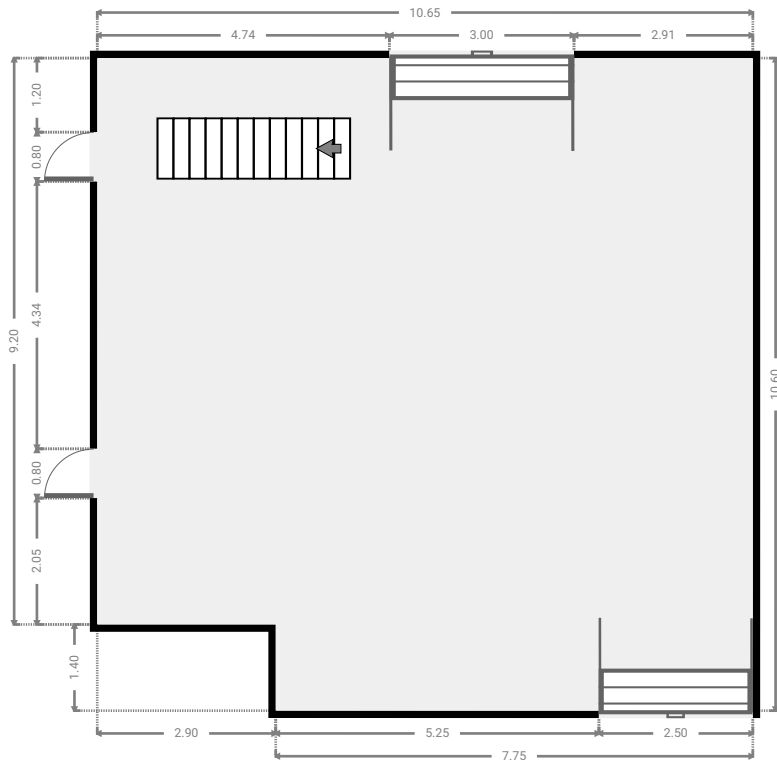
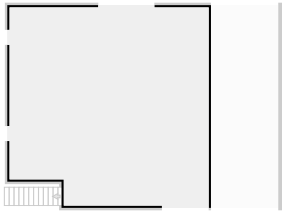

▼ **Other**
Ground Floor

WIDTH: 3.60 m • LENGTH: 10.60 m
AREA: 38.16 m² • PERIMETER: 28.40 m

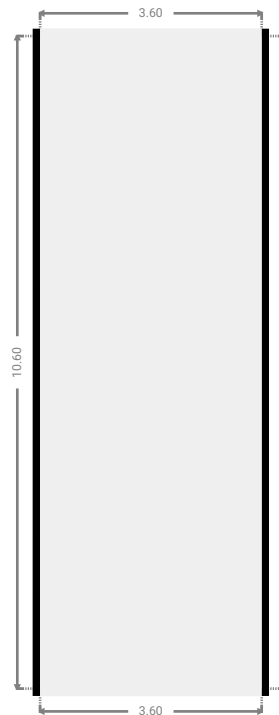

▼ 1st Floor

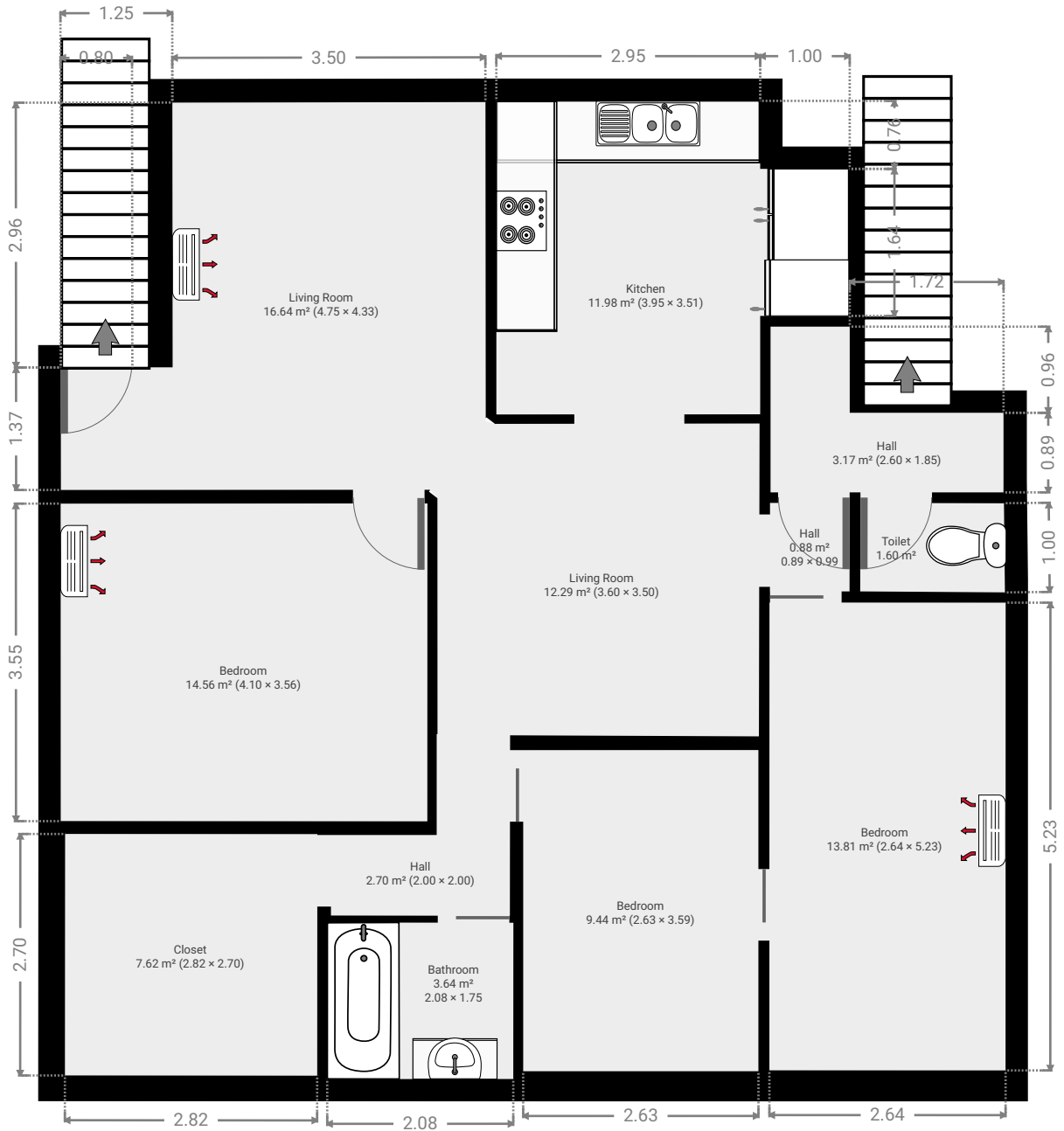

▼ Living Room
1st Floor

WIDTH: 4.33 m • LENGTH: 4.75 m
AREA: 16.64 m² • PERIMETER: 17.76 m

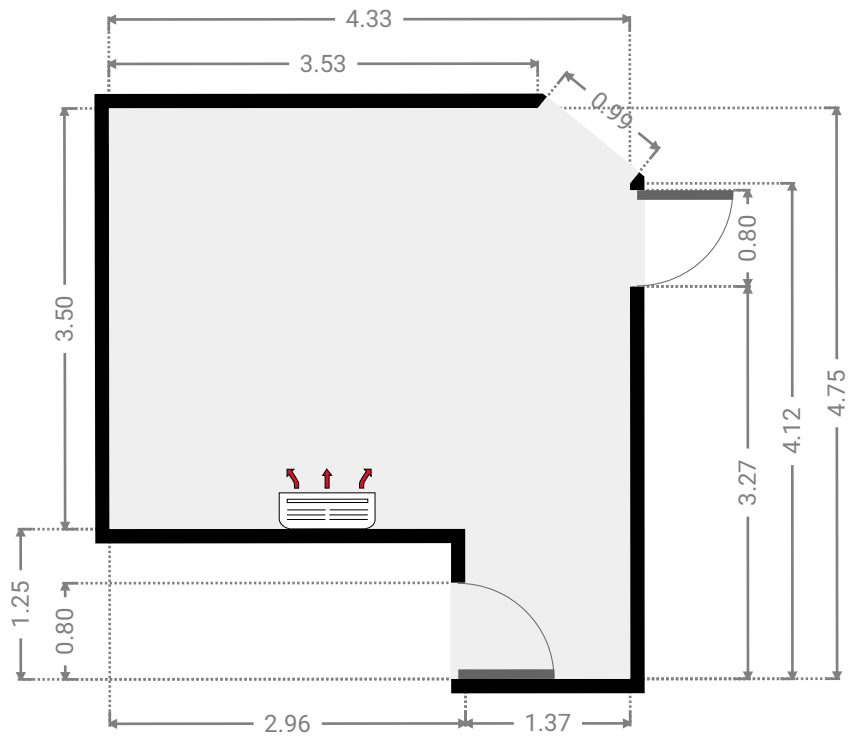
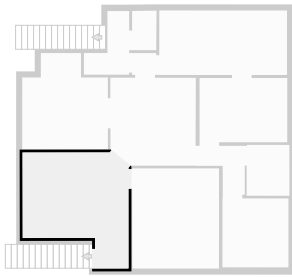

▼ Bedroom
1st Floor

WIDTH: 3.56 m • LENGTH: 4.10 m
AREA: 14.56 m² • PERIMETER: 15.30 m

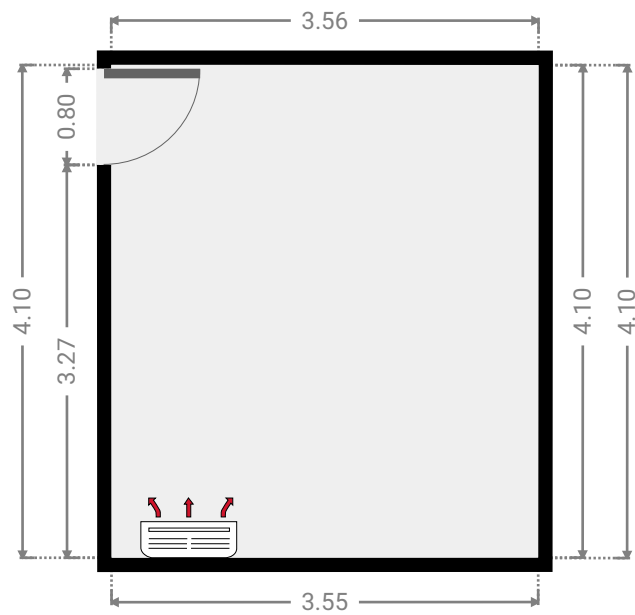
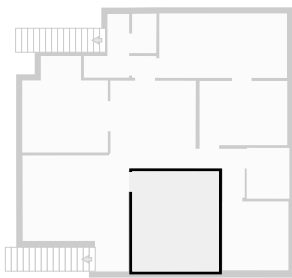

▼ Closet
1st Floor

WIDTH: 2.70 m • LENGTH: 2.82 m
AREA: 7.62 m² • PERIMETER: 11.04 m

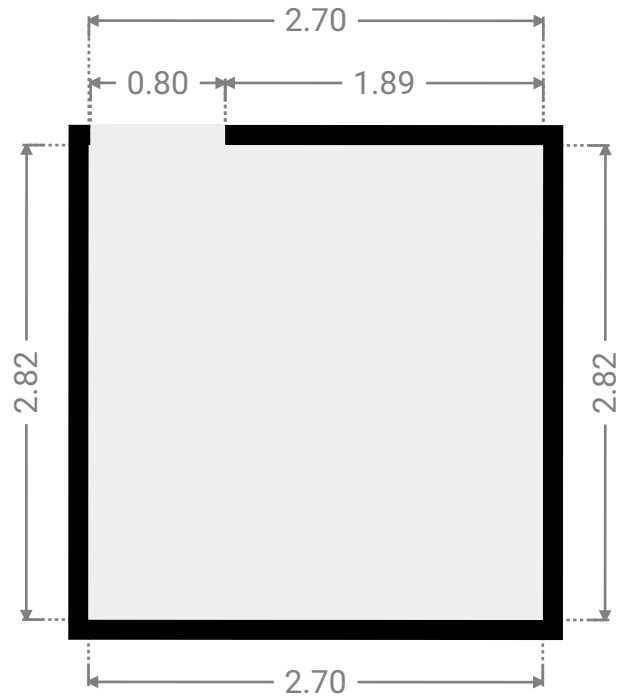
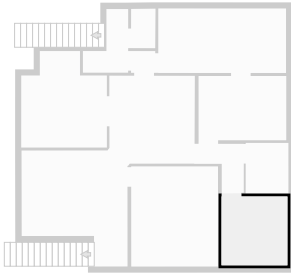

▼ Hall
1st Floor

WIDTH: 2.00 m • LENGTH: 2.00 m
AREA: 2.70 m² • PERIMETER: 8.00 m

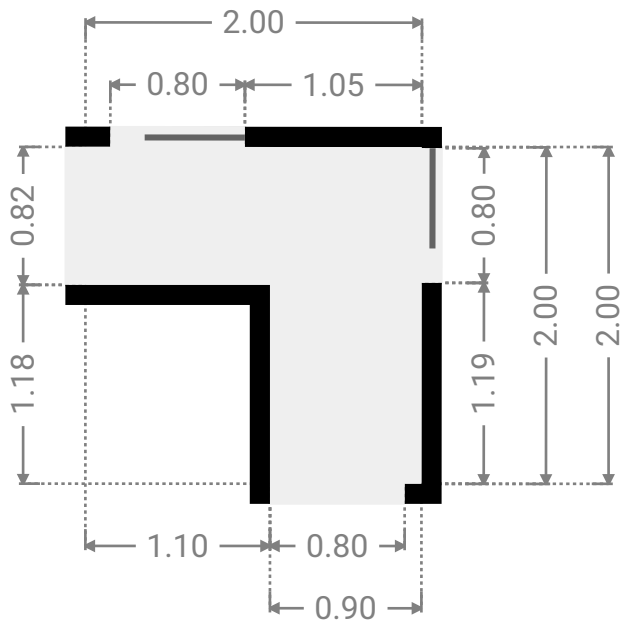

▼ **Bathroom**
1st Floor

WIDTH: 1.75 m • LENGTH: 2.08 m
AREA: 3.64 m² • PERIMETER: 7.66 m

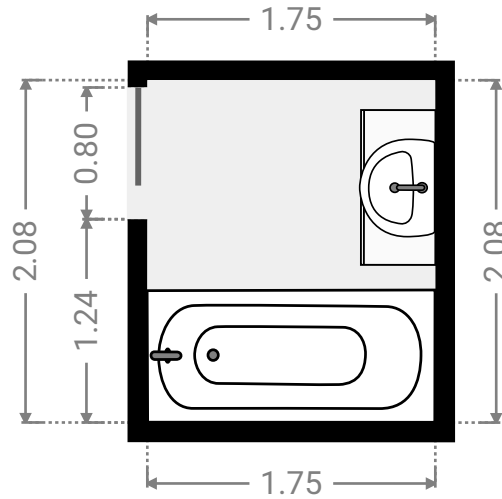
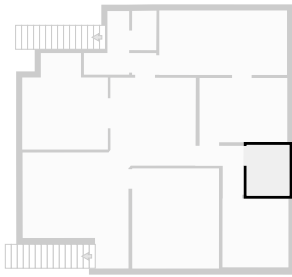

▼ **Bedroom**
1st Floor

WIDTH: 3.59 m • LENGTH: 2.63 m
AREA: 9.44 m² • PERIMETER: 12.44 m

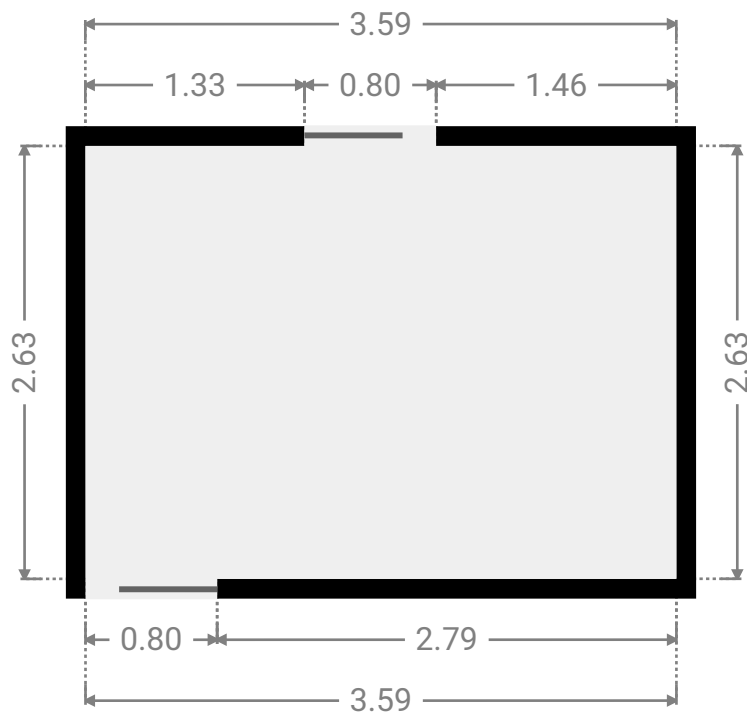
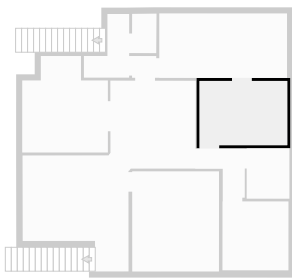

▼ **Living Room**
1st Floor

WIDTH: 3.50 m • LENGTH: 3.60 m
AREA: 12.29 m² • PERIMETER: 13.75 m

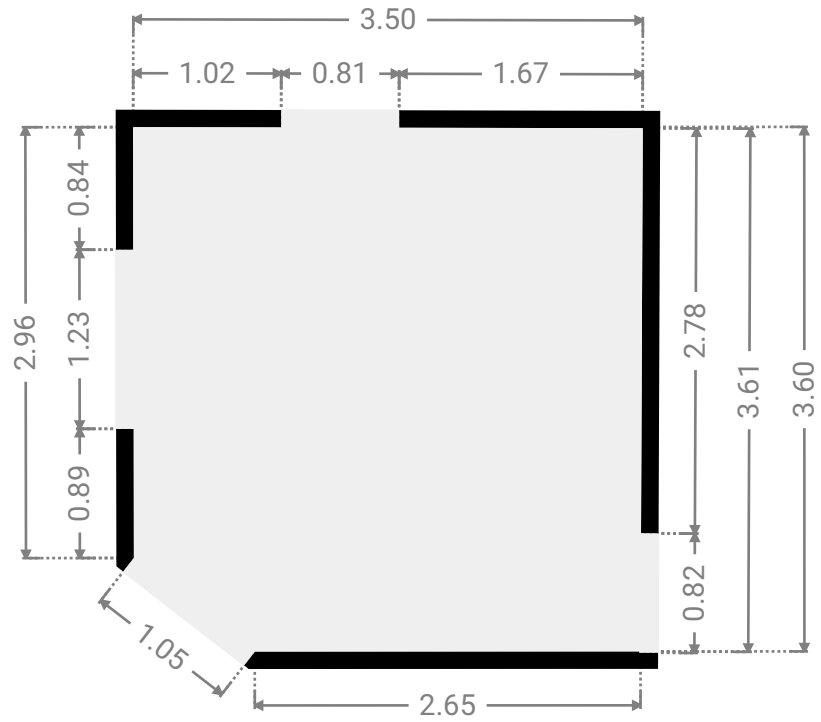
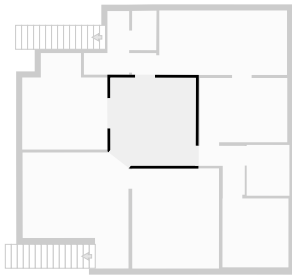

▼ **Kitchen**
1st Floor

WIDTH: 3.51 m • LENGTH: 3.95 m
AREA: 11.98 m² • PERIMETER: 14.91 m

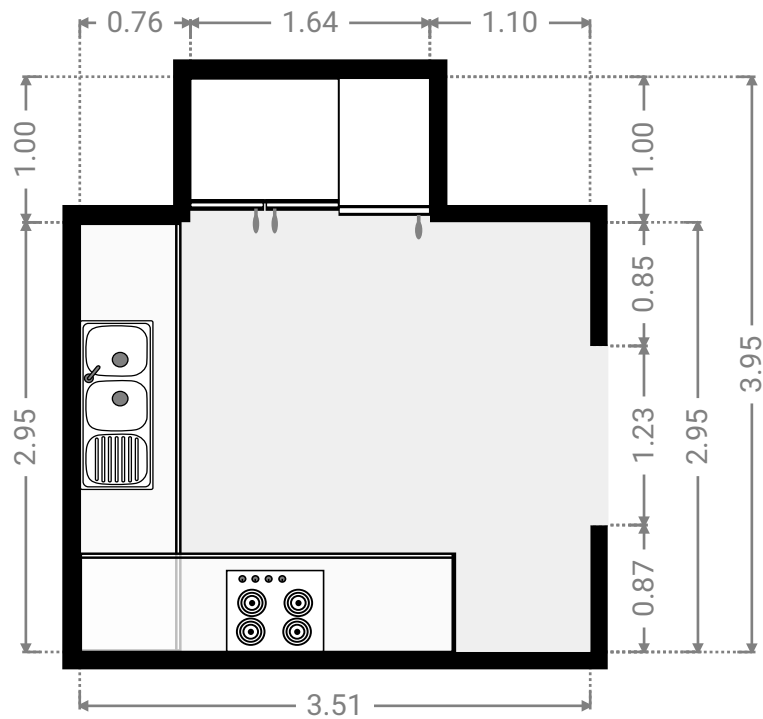
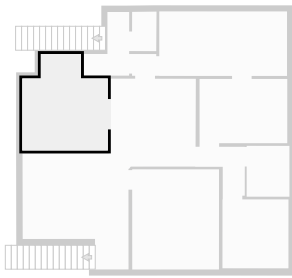

▼ **Hall**
1st Floor

WIDTH: 0.99 m • LENGTH: 0.89 m
AREA: 0.88 m² • PERIMETER: 3.76 m

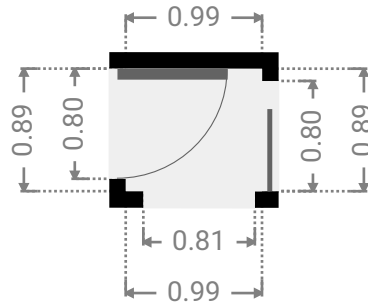
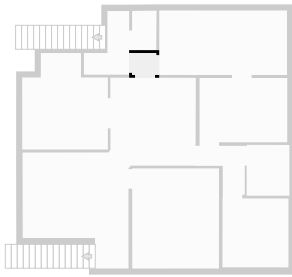

▼ **Bedroom**
1st Floor

WIDTH: 5.23 m • LENGTH: 2.64 m
AREA: 13.81 m² • PERIMETER: 15.74 m

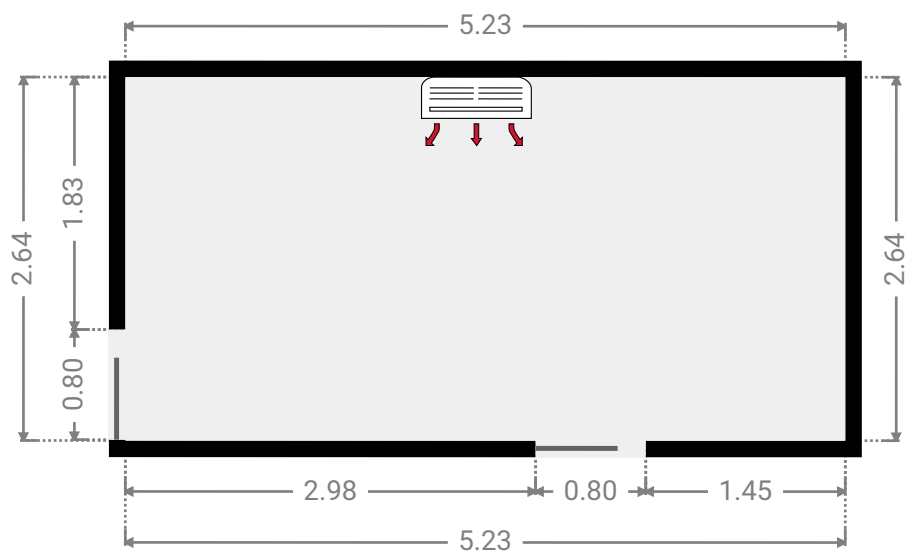
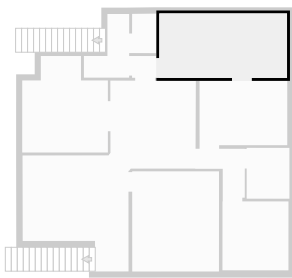

▼ **Hall**
1st Floor

WIDTH: 1.85 m • LENGTH: 2.60 m
AREA: 3.17 m² • PERIMETER: 8.91 m

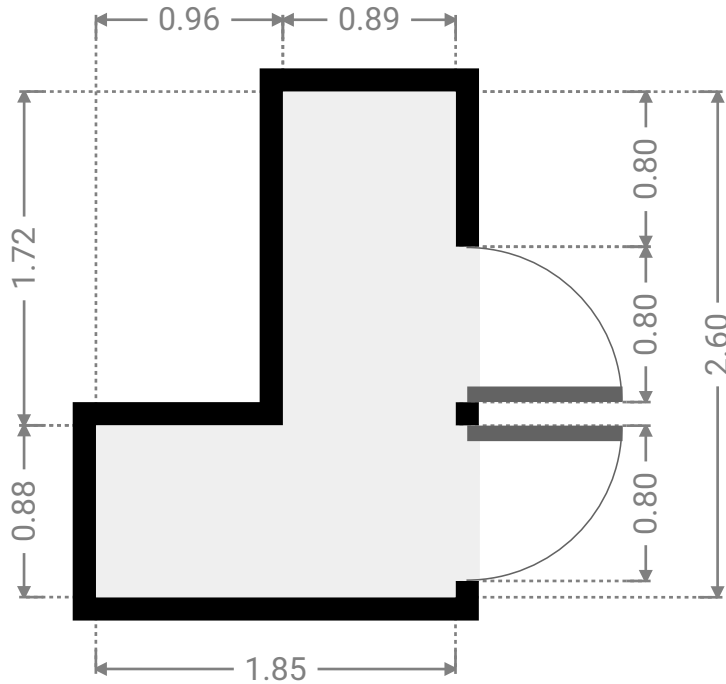
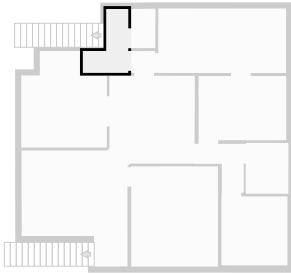

▼ **Toilet**
1st Floor

WIDTH: 1.00 m • LENGTH: 1.62 m
AREA: 1.60 m² • PERIMETER: 5.21 m

