

15 Mossvale Drive

SUBMITTED BY

Ray White Rockhampton Casey
stockers@cqoz.com

CREATED ON

2022-12-07

Floors

1

▼ Ground Floor



▼ Bathroom
Ground Floor

WIDTH: 3.35 m • LENGTH: 2.35 m
AREA: 7.85 m² • PERIMETER: 11.39 m

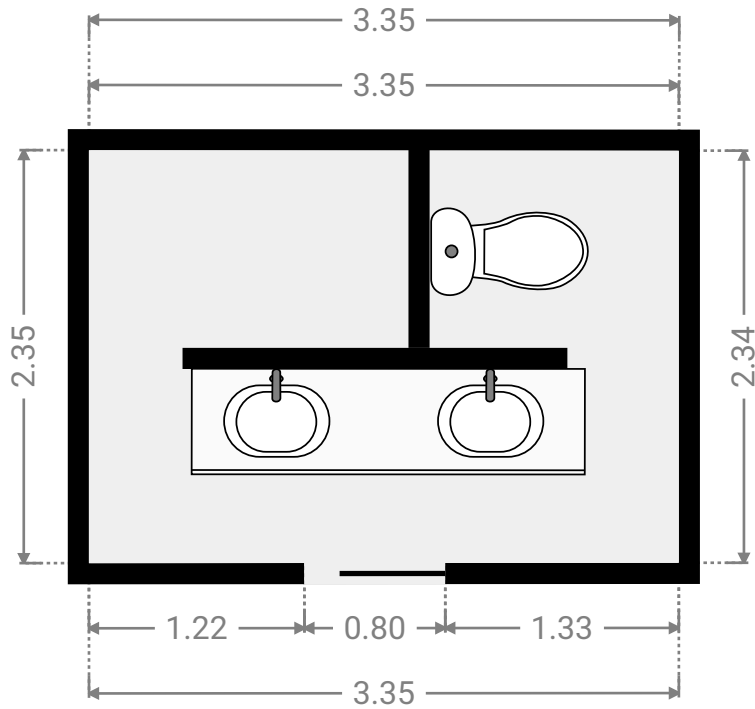
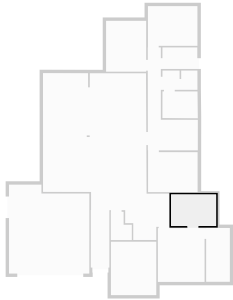

▼ Bathroom
Ground Floor

WIDTH: 2.64 m • LENGTH: 1.99 m
AREA: 5.20 m² • PERIMETER: 9.21 m

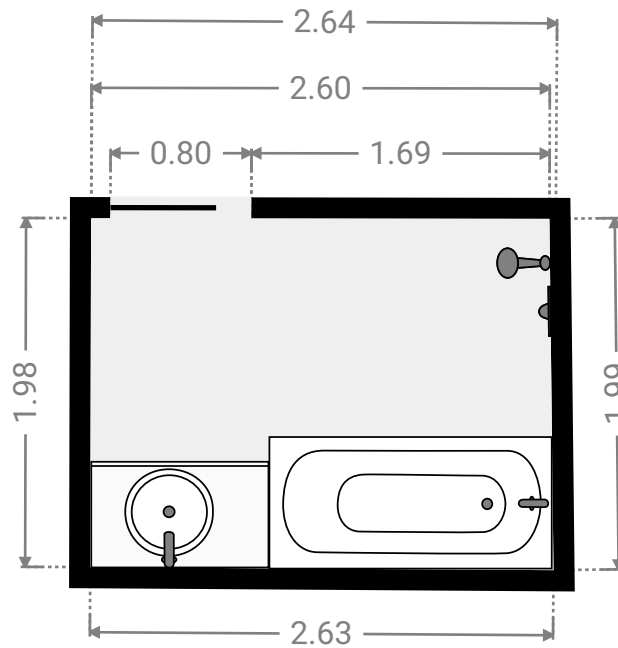
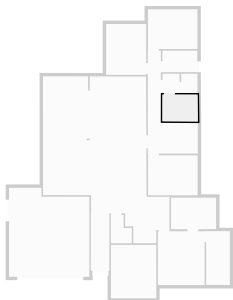

FLOORS: 1

▼ **Bedroom**
Ground Floor

WIDTH: 3.47 m • LENGTH: 4.00 m
AREA: 13.88 m² • PERIMETER: 14.94 m

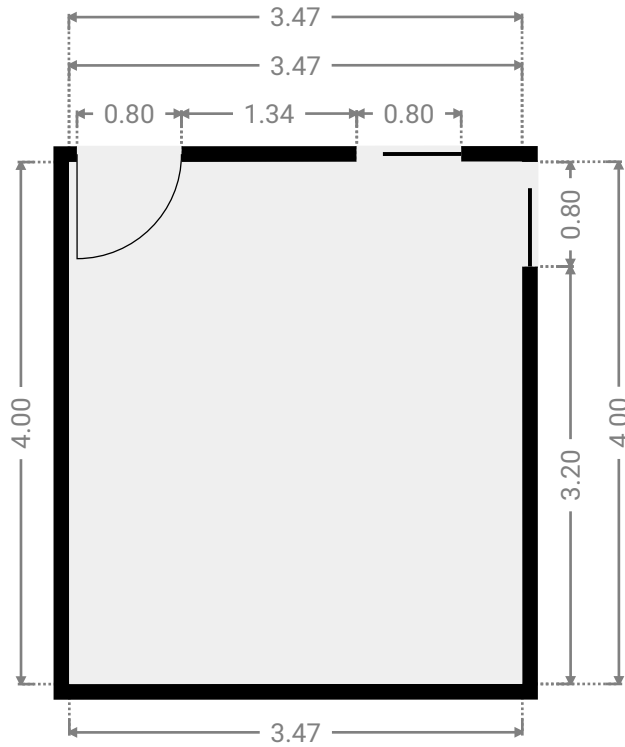
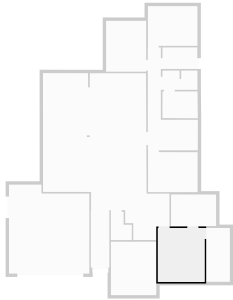

▼ **Closet**
Ground Floor

WIDTH: 1.76 m • LENGTH: 4.00 m
AREA: 7.04 m² • PERIMETER: 11.52 m

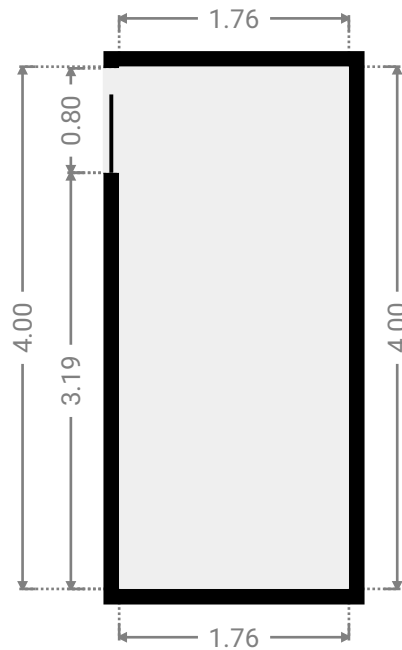
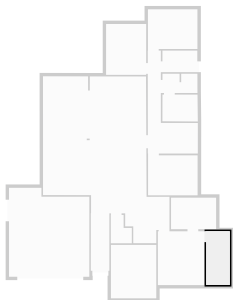

FLOORS: 1

▼ **Bedroom**
Ground Floor

WIDTH: 2.98 m • LENGTH: 3.78 m
AREA: 11.26 m² • PERIMETER: 13.52 m

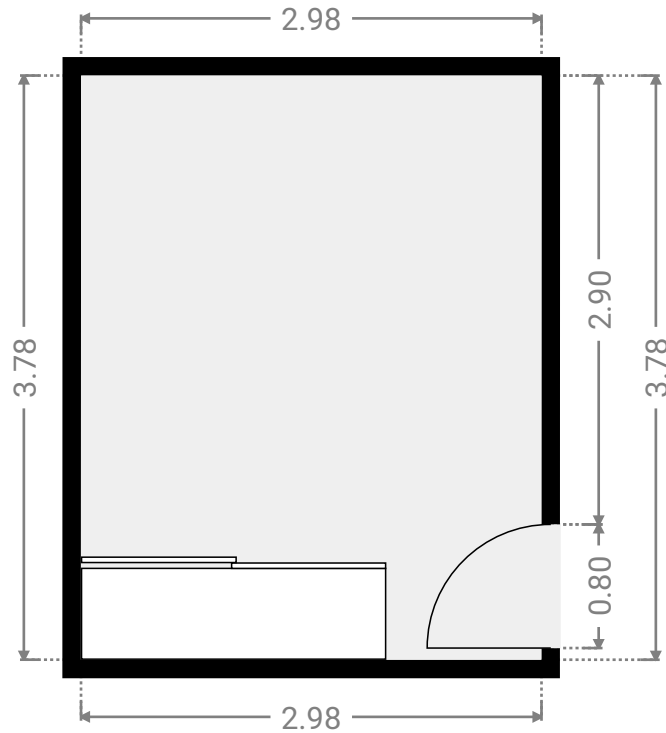
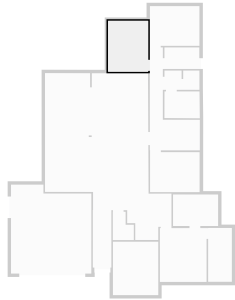

▼ **Bedroom**
Ground Floor

WIDTH: 3.68 m • LENGTH: 2.95 m
AREA: 10.86 m² • PERIMETER: 13.26 m

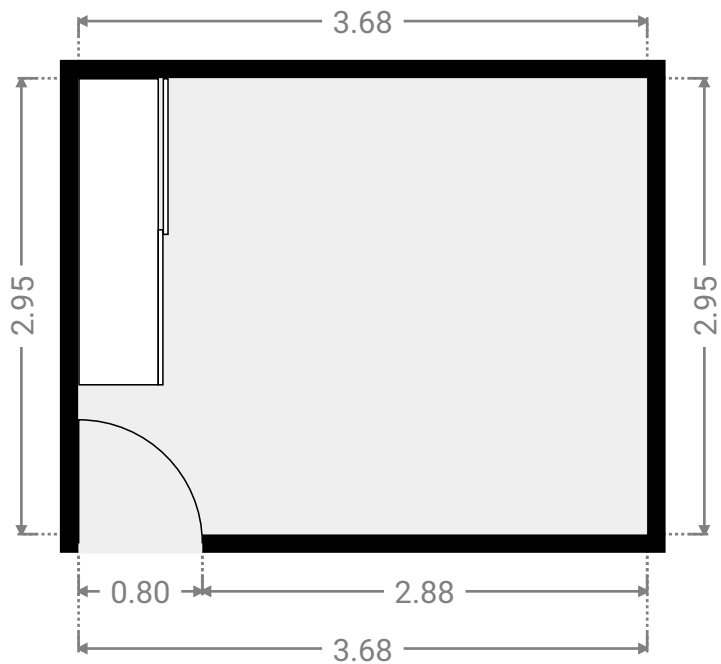
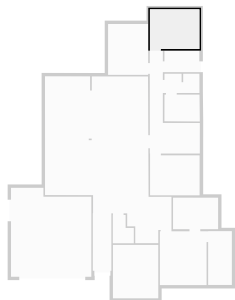

FLOORS: 1

▼ **Bedroom**
Ground Floor

WIDTH: 3.68 m • LENGTH: 2.97 m
AREA: 10.93 m² • PERIMETER: 13.30 m

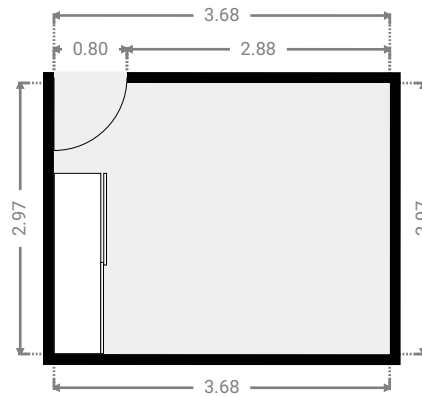
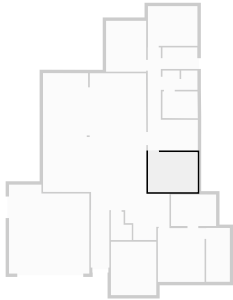

▼ **Garage**
Ground Floor

WIDTH: 5.97 m • LENGTH: 6.61 m
AREA: 37.12 m² • PERIMETER: 25.16 m

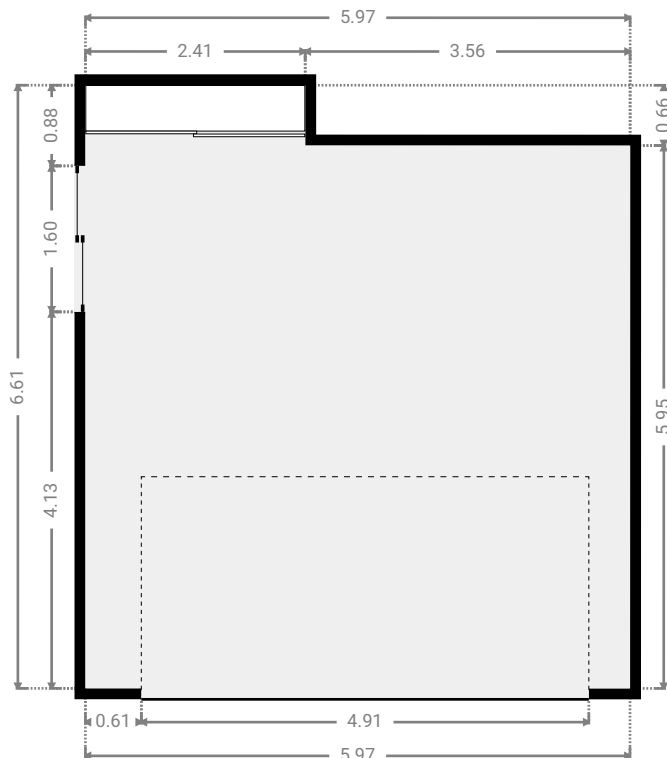
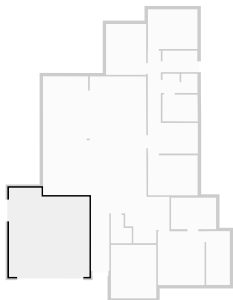

▼ Hall Ground Floor

WIDTH: 1.38 m • LENGTH: 4.15 m
AREA: 5.72 m² • PERIMETER: 11.06 m

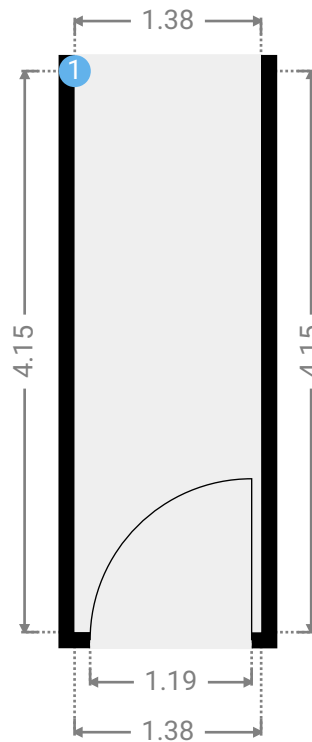
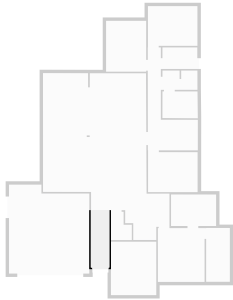

▼ Hall/Ground Floor

1 OPENING

Height
0.00 m



▼ Hall
Ground Floor

WIDTH: 3.72 m • LENGTH: 7.65 m
AREA: 13.65 m² • PERIMETER: 22.73 m

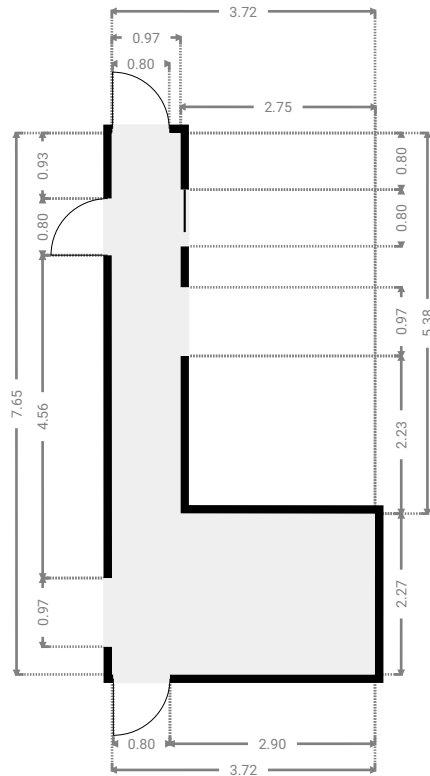
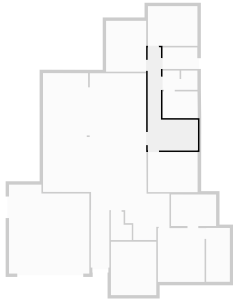

▼ Hall
Ground Floor

WIDTH: 1.27 m • LENGTH: 1.43 m
AREA: 1.82 m² • PERIMETER: 5.40 m

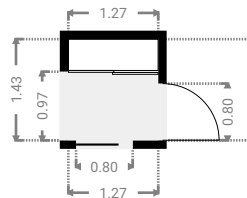
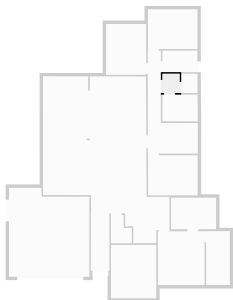

▼ Kitchen
Ground Floor

WIDTH: 9.40 m • LENGTH: 12.41 m
AREA: 64.54 m² • PERIMETER: 43.54 m

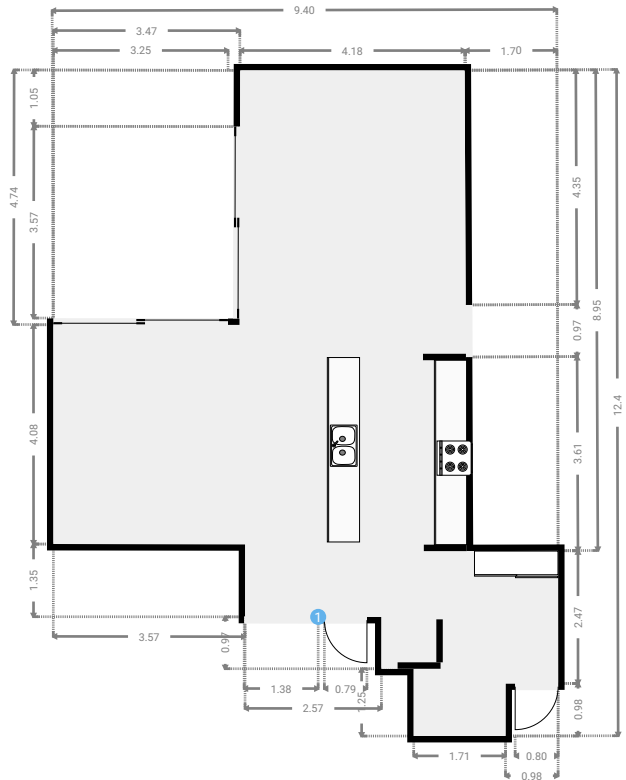
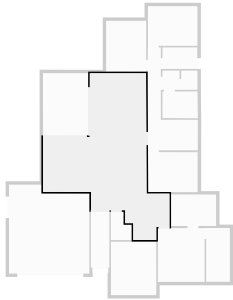

▼ Closet
Ground Floor

WIDTH: 1.56 m • LENGTH: 2.11 m
AREA: 2.70 m² • PERIMETER: 7.33 m

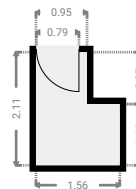
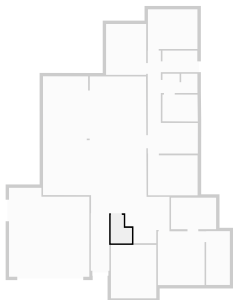

FLOORS: 1

▼ Laundry Room
Ground Floor

WIDTH: 2.59 m • LENGTH: 1.60 m
AREA: 4.14 m² • PERIMETER: 8.38 m

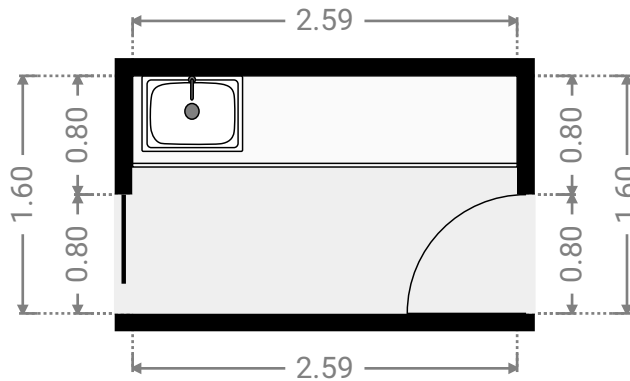
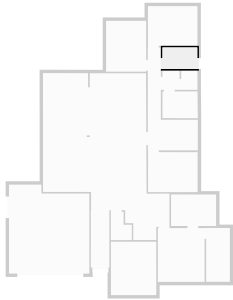

▼ Living Room
Ground Floor

WIDTH: 3.37 m • LENGTH: 3.97 m
AREA: 13.38 m² • PERIMETER: 14.68 m

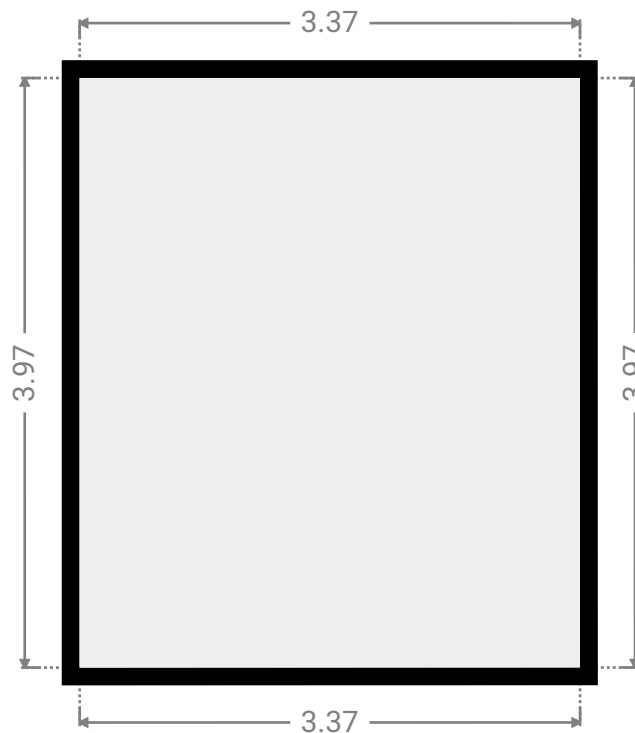
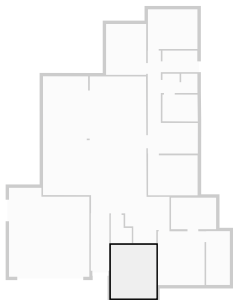

FLOORS: 1

▼ Other Ground Floor

WIDTH: 3.36 m • LENGTH: 4.64 m
AREA: 15.54 m² • PERIMETER: 15.97 m

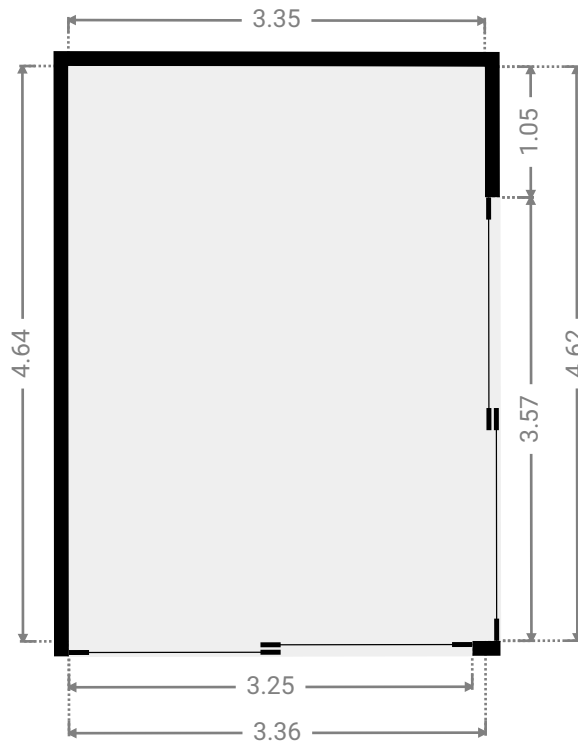
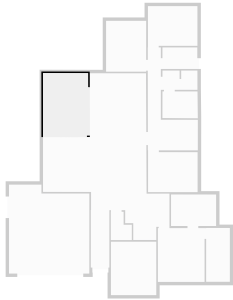

▼ Toilet Ground Floor

WIDTH: 1.21 m • LENGTH: 1.43 m
AREA: 1.73 m² • PERIMETER: 5.27 m

