

15 Davidson Street

SUBMITTED BY

Ray White Rockhampton Casey
stockers@cqoz.com

CREATED ON

2022-05-11

Floors

1

▼ Ground Floor

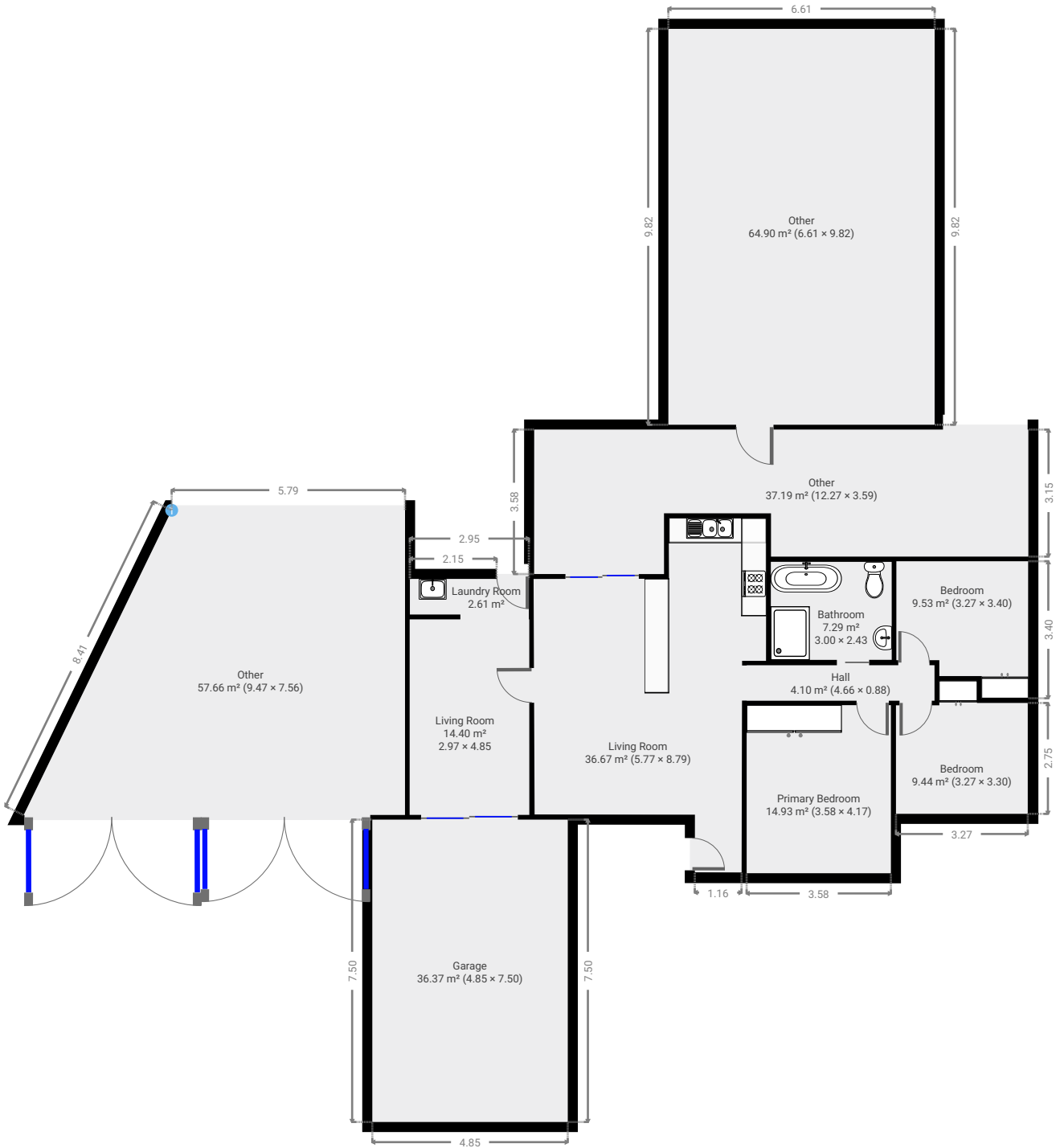

▼ **Bathroom**
Ground Floor

WIDTH: 3.00 m • LENGTH: 2.43 m
AREA: 7.29 m² • PERIMETER: 10.86 m

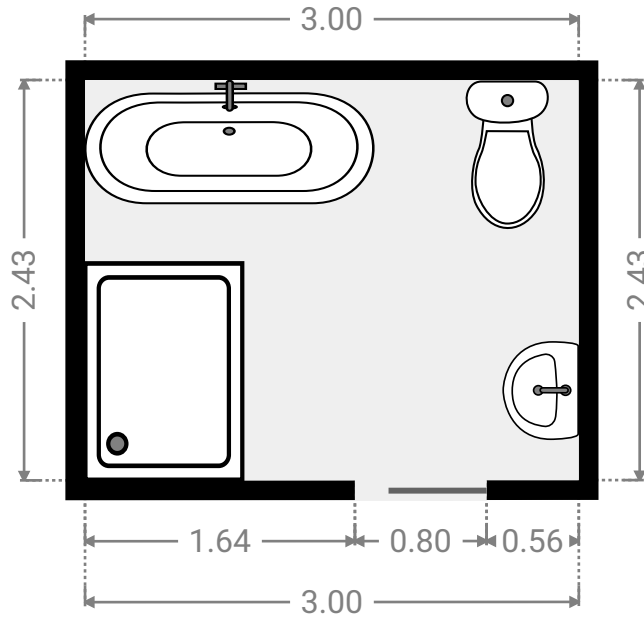
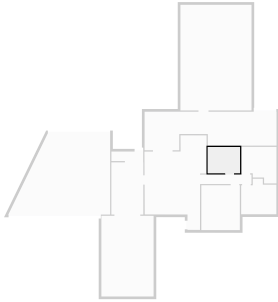

▼ **Bedroom**
Ground Floor

WIDTH: 3.27 m • LENGTH: 3.40 m
AREA: 9.53 m² • PERIMETER: 13.34 m

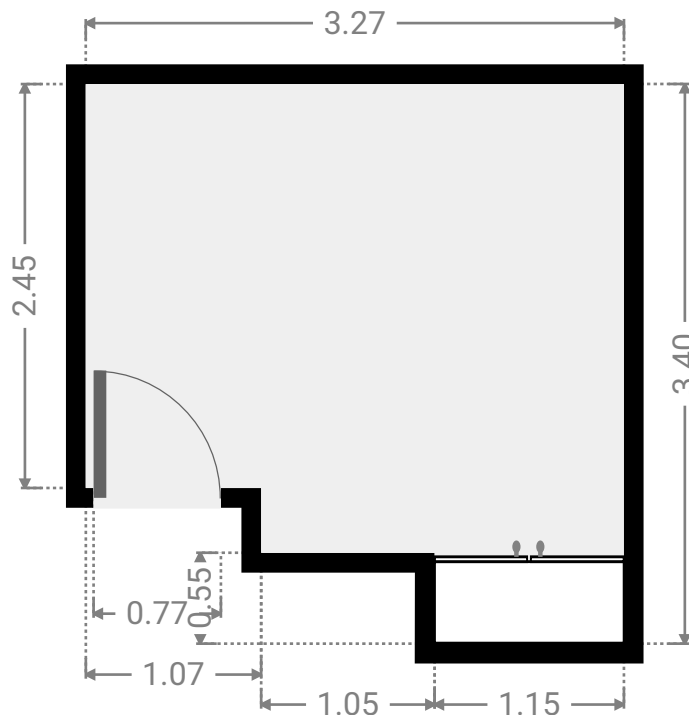
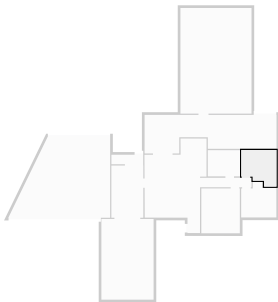

FLOORS: 1

▼ **Bedroom**
Ground Floor

WIDTH: 3.27 m • LENGTH: 3.30 m
AREA: 9.44 m² • PERIMETER: 13.14 m

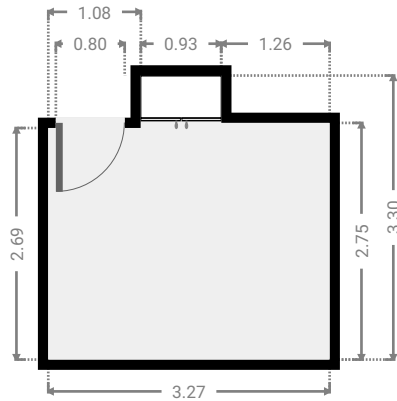
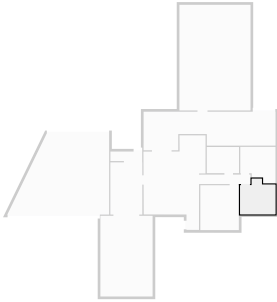

▼ **Garage**
Ground Floor

WIDTH: 4.85 m • LENGTH: 7.50 m
AREA: 36.37 m² • PERIMETER: 24.70 m

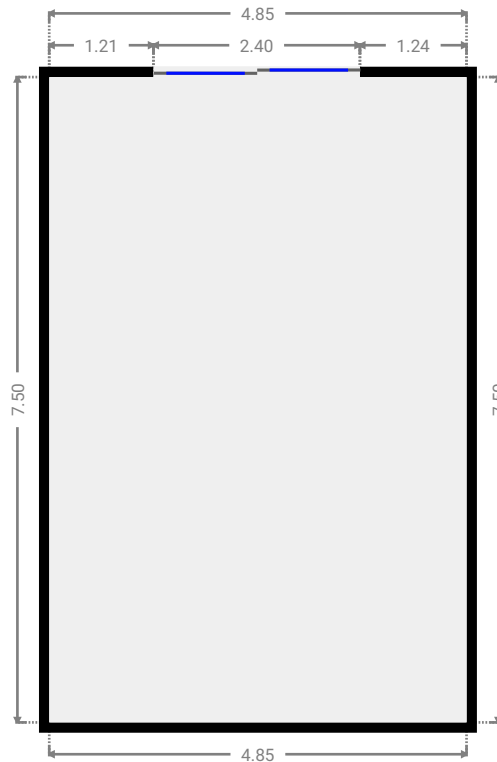
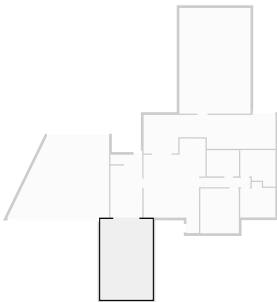

▼ Hall
Ground Floor

WIDTH: 4.66 m • LENGTH: 0.88 m
AREA: 4.10 m² • PERIMETER: 11.08 m

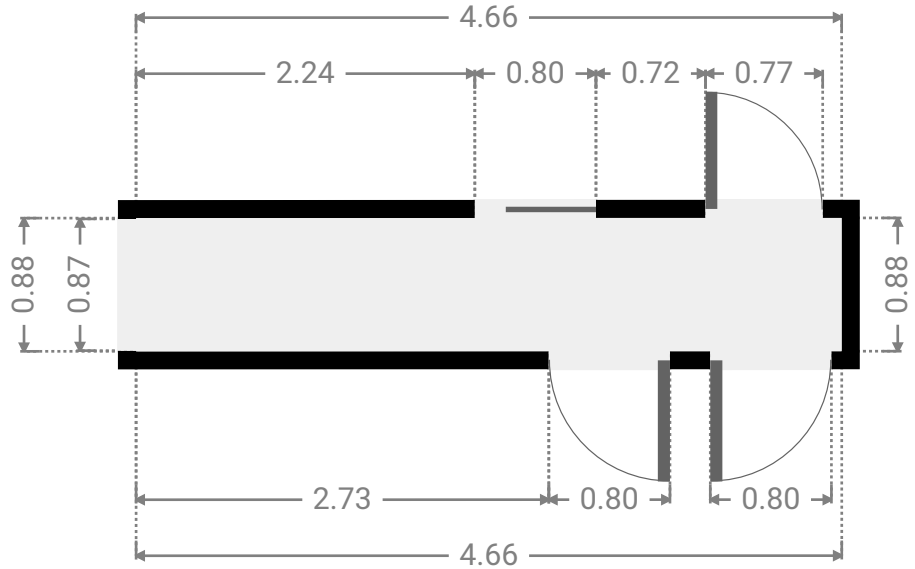
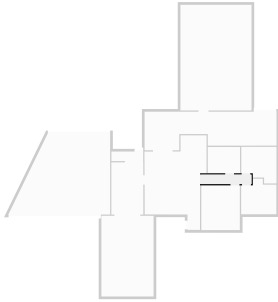

▼ Laundry Room
Ground Floor

WIDTH: 2.95 m • LENGTH: 0.88 m
AREA: 2.61 m² • PERIMETER: 7.67 m

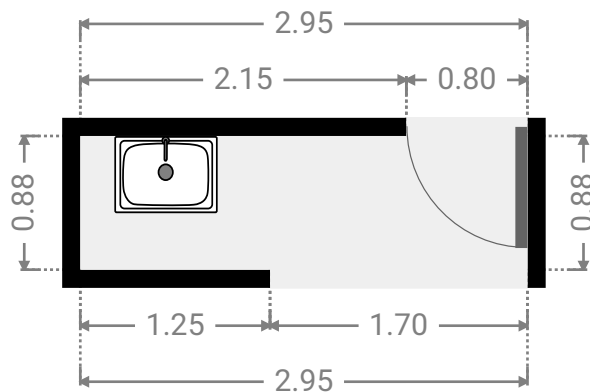

FLOORS: 1

▼ Living Room
Ground Floor

WIDTH: 5.77 m • LENGTH: 8.79 m
AREA: 36.67 m² • PERIMETER: 29.08 m

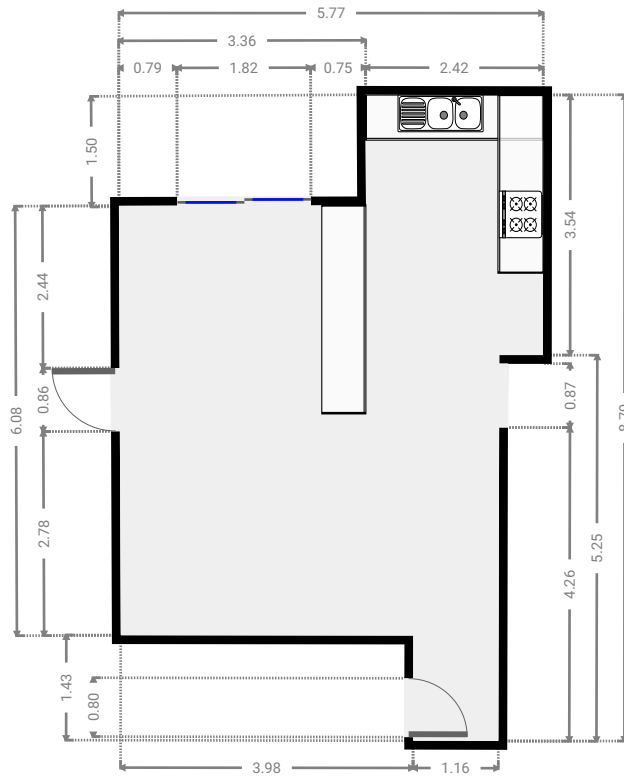
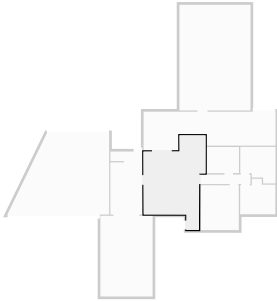

▼ Living Room
Ground Floor

WIDTH: 2.97 m • LENGTH: 4.85 m
AREA: 14.40 m² • PERIMETER: 15.64 m

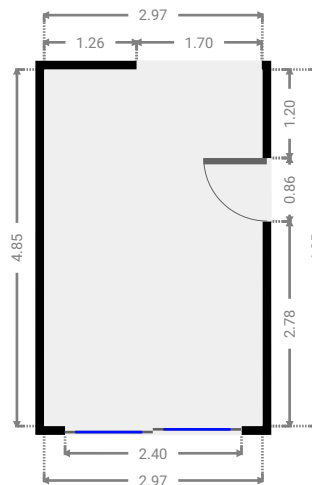
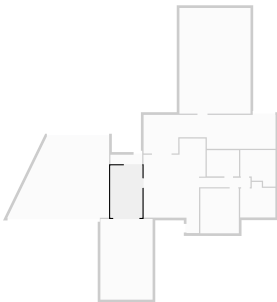

FLOORS: 1

▼ Other
Ground Floor

WIDTH: 9.47 m • LENGTH: 7.56 m
AREA: 57.66 m² • PERIMETER: 31.22 m

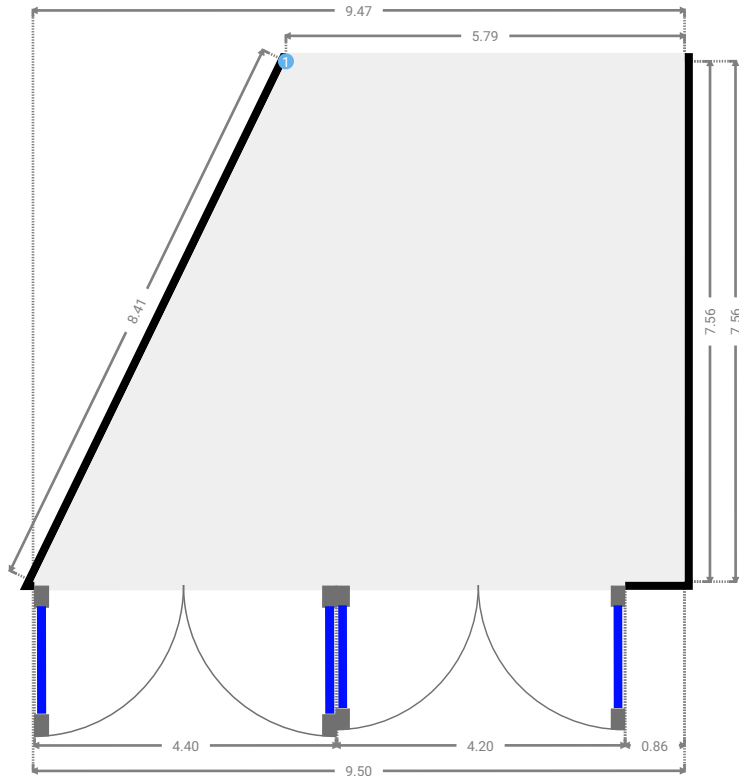
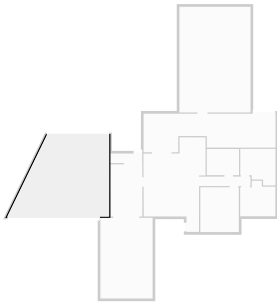

▼ Other/Ground Floor

1 OPENING

Height
0.00 m



FLOORS: 1

▼ **Other**
Ground Floor

WIDTH: 12.27 m • LENGTH: 3.59 m
AREA: 37.19 m² • PERIMETER: 33.85 m

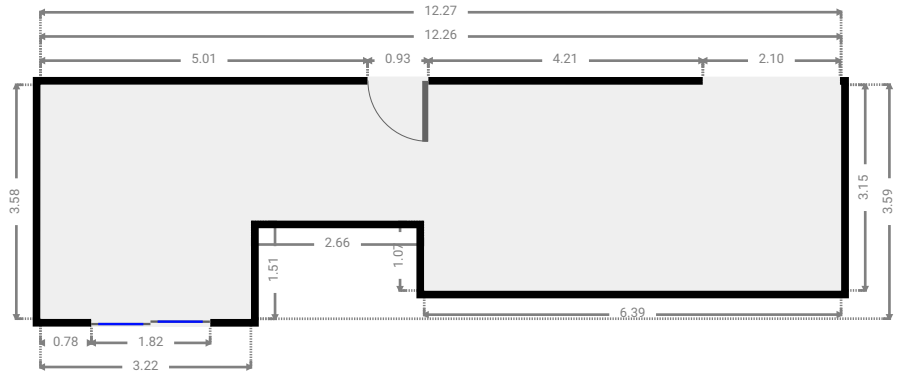
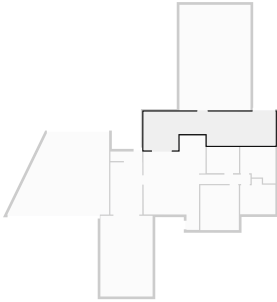

▼ **Other**
Ground Floor

WIDTH: 6.61 m • LENGTH: 9.82 m
AREA: 64.90 m² • PERIMETER: 32.86 m

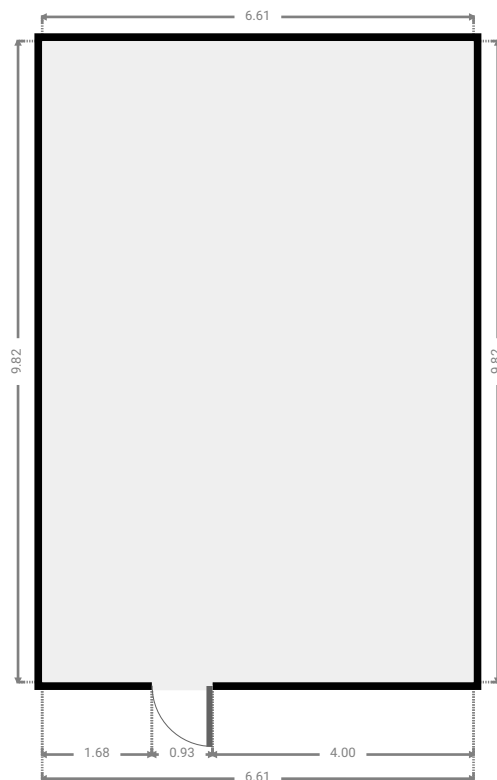
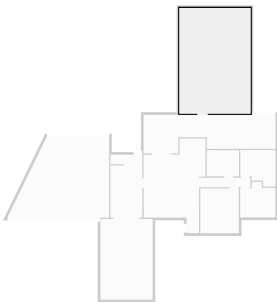

▼ **Primary Bedroom**
Ground Floor

WIDTH: 3.58 m • LENGTH: 4.17 m
AREA: 14.93 m² • PERIMETER: 15.50 m

