

15 Brosnan Crescent , Parkhurst

SUBMITTED BY
Janelle Casey

CREATED ON
2016-10-27

Floors 1

FLOORS: 1

▼ Ground Floor

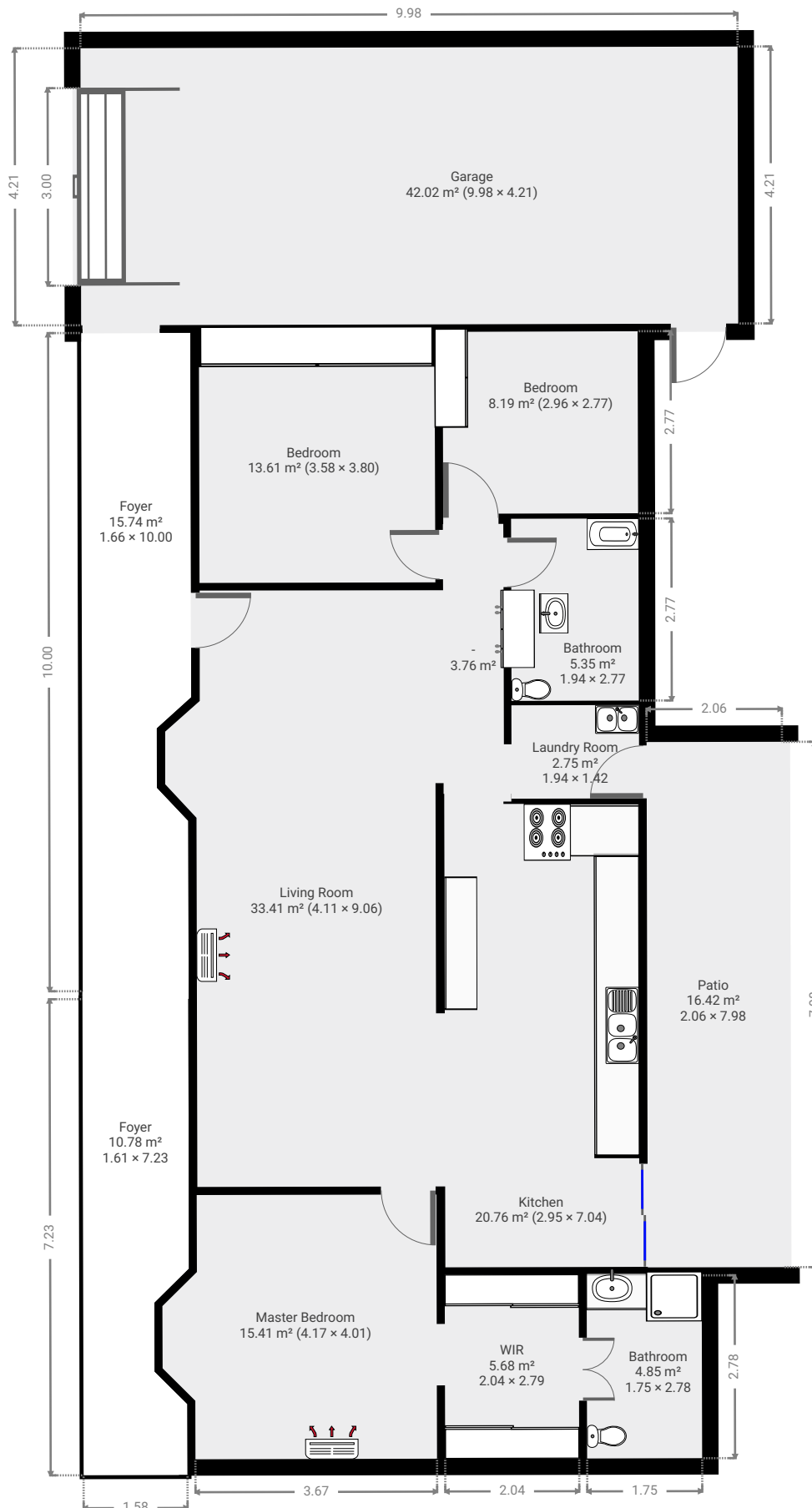

THIS FLOORPLAN IS PROVIDED WITHOUT WARRANTY OF ANY KIND. SENSOPIA DISCLAIMS ANY WARRANTY INCLUDING, WITHOUT LIMITATION, SATISFACTORY QUALITY OR ACCURACY OF DIMENSIONS.

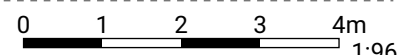

FLOORS: 1

▼ **Kitchen**
Ground Floor

WIDTH: 7.04 m • LENGTH: 2.95 m
AREA: 20.76 m² • PERIMETER: 19.97 m

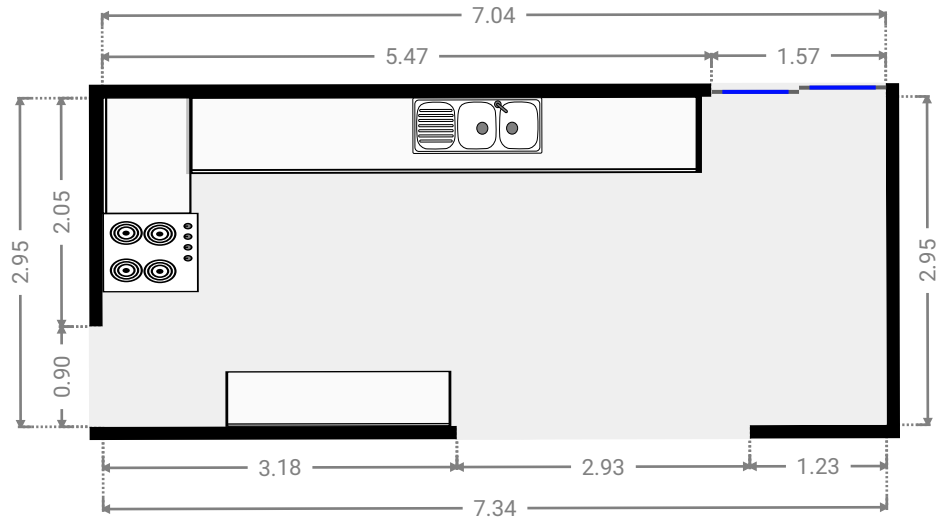
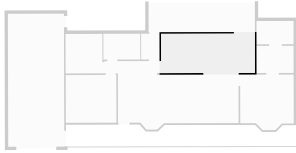

▼ **WIR**
Ground Floor

WIDTH: 2.79 m • LENGTH: 2.04 m
AREA: 5.68 m² • PERIMETER: 9.65 m

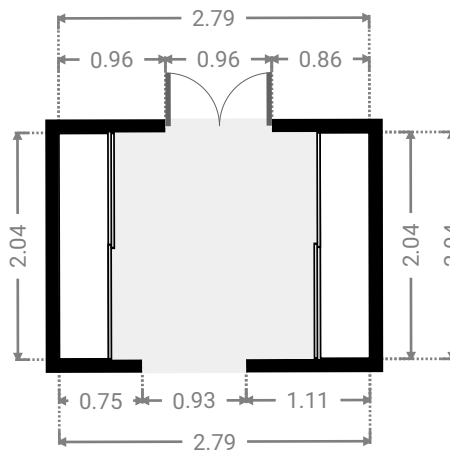
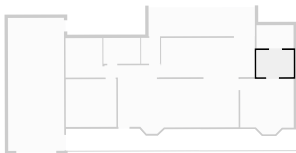

FLOORS: 1

▼ **Bathroom**
Ground Floor

WIDTH: 2.78 m • LENGTH: 1.75 m
AREA: 4.85 m² • PERIMETER: 9.05 m

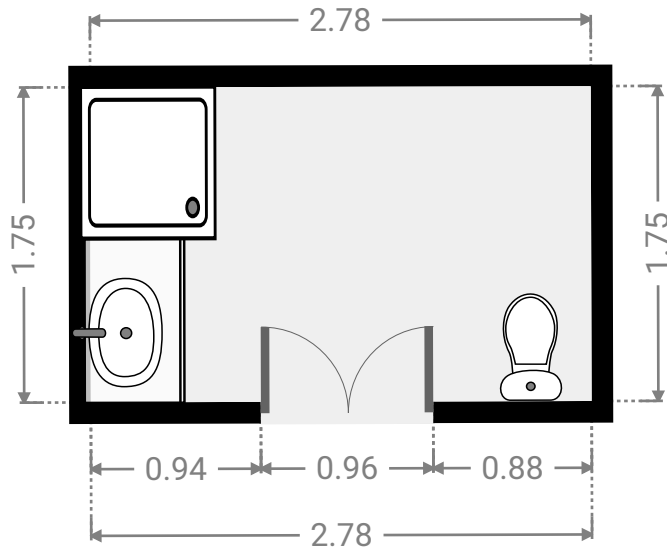
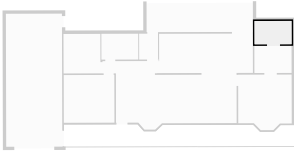

▼ **Laundry Room**
Ground Floor

WIDTH: 1.42 m • LENGTH: 1.94 m
AREA: 2.75 m² • PERIMETER: 6.71 m

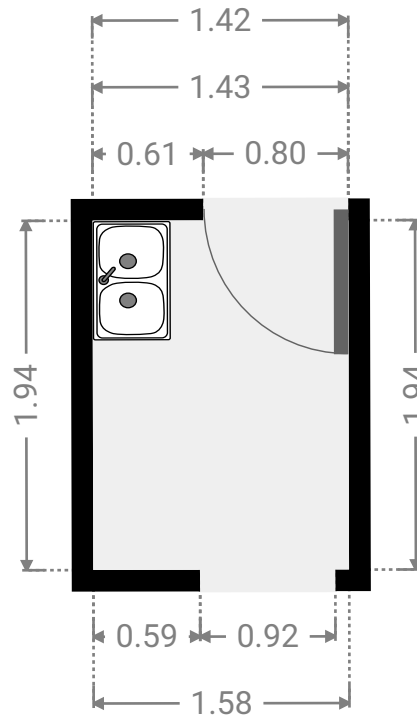
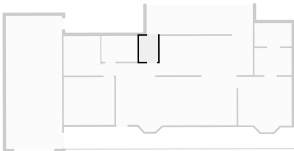

FLOORS: 1

▼ **Bathroom**
Ground Floor

WIDTH: 2.77 m • LENGTH: 1.94 m
AREA: 5.35 m² • PERIMETER: 9.40 m

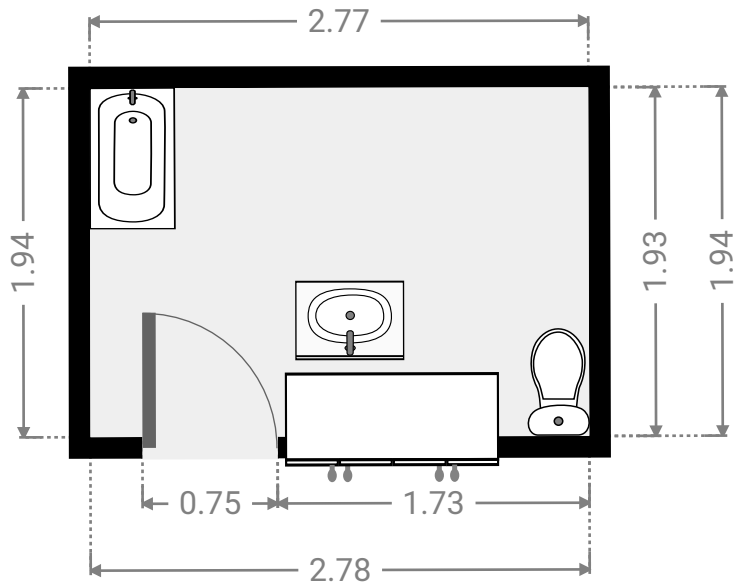
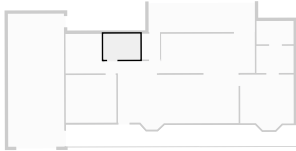

▼ **Bedroom**
Ground Floor

WIDTH: 2.77 m • LENGTH: 2.96 m
AREA: 8.19 m² • PERIMETER: 11.45 m

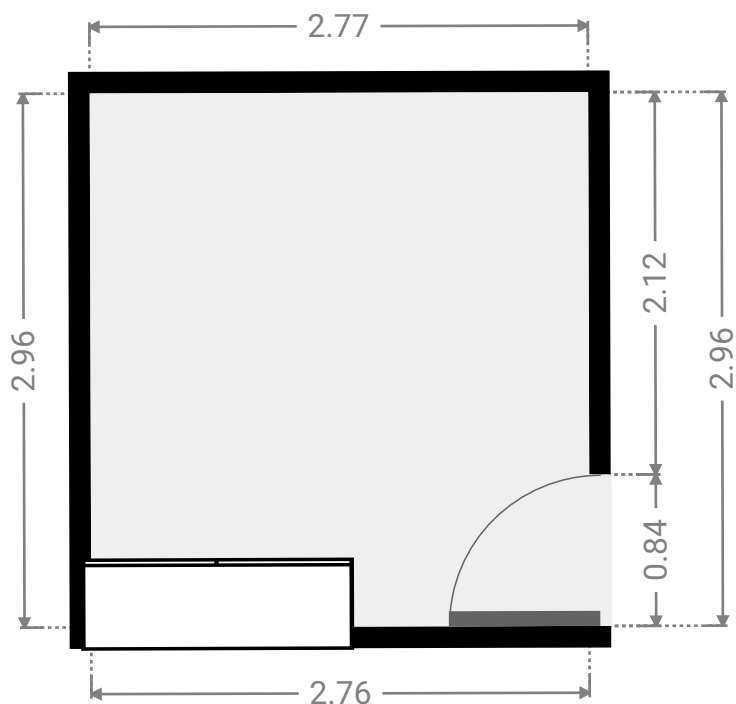
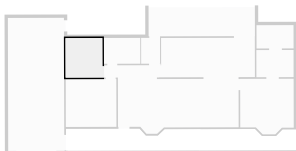

FLOORS: 1

▼ **Bedroom**
Ground Floor

WIDTH: 3.80 m • LENGTH: 3.58 m • CEILING HEIGHT: 2.17 m
AREA: 13.61 m² • PERIMETER: 14.76 m

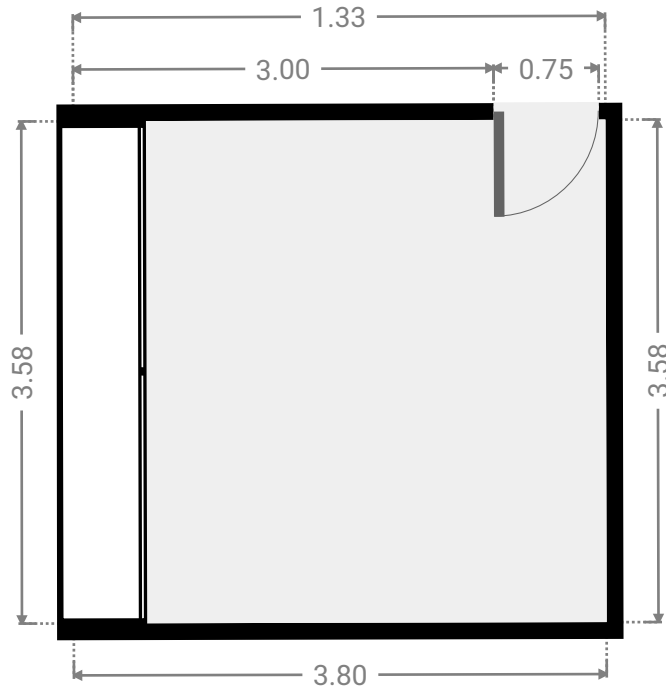
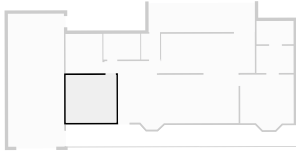

▼ -
Ground Floor

WIDTH: 4.09 m • LENGTH: 0.92 m
AREA: 3.76 m² • PERIMETER: 10.03 m

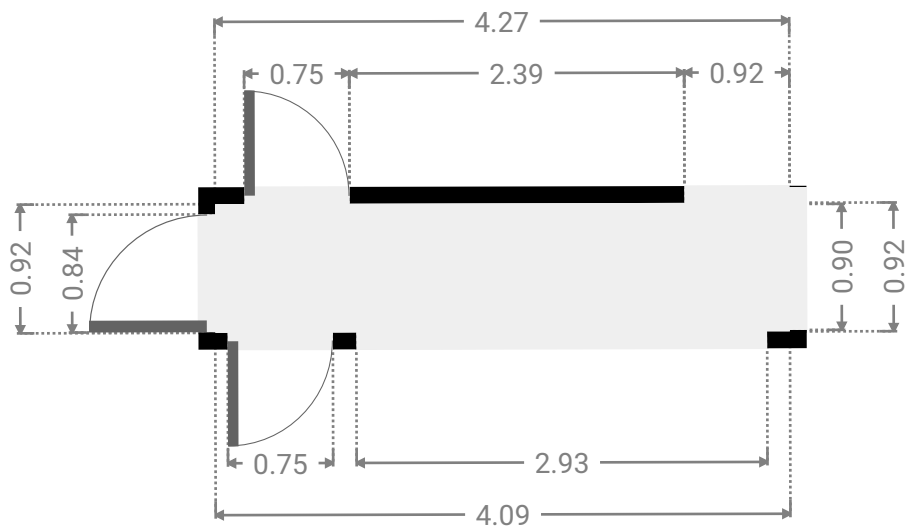
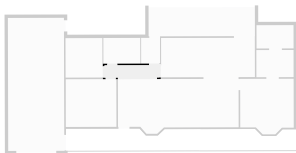

FLOORS: 1

▼ **Master Bedroom**
Ground Floor

WIDTH: 4.01 m • LENGTH: 4.17 m • CEILING HEIGHT: 2.17 m
AREA: 15.41 m² • PERIMETER: 15.77 m

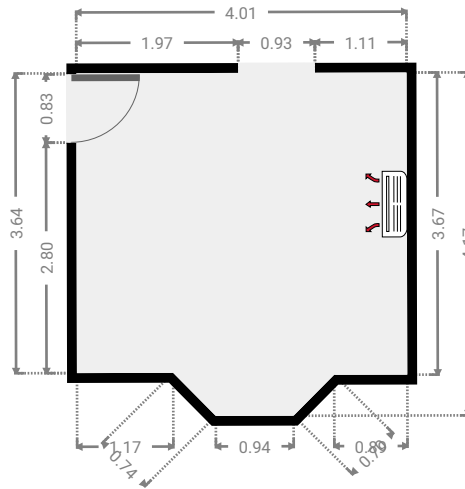

▼ **Living Room**
Ground Floor

WIDTH: 9.06 m • LENGTH: 4.11 m • CEILING HEIGHT: 2.17 m
AREA: 33.41 m² • PERIMETER: 25.75 m

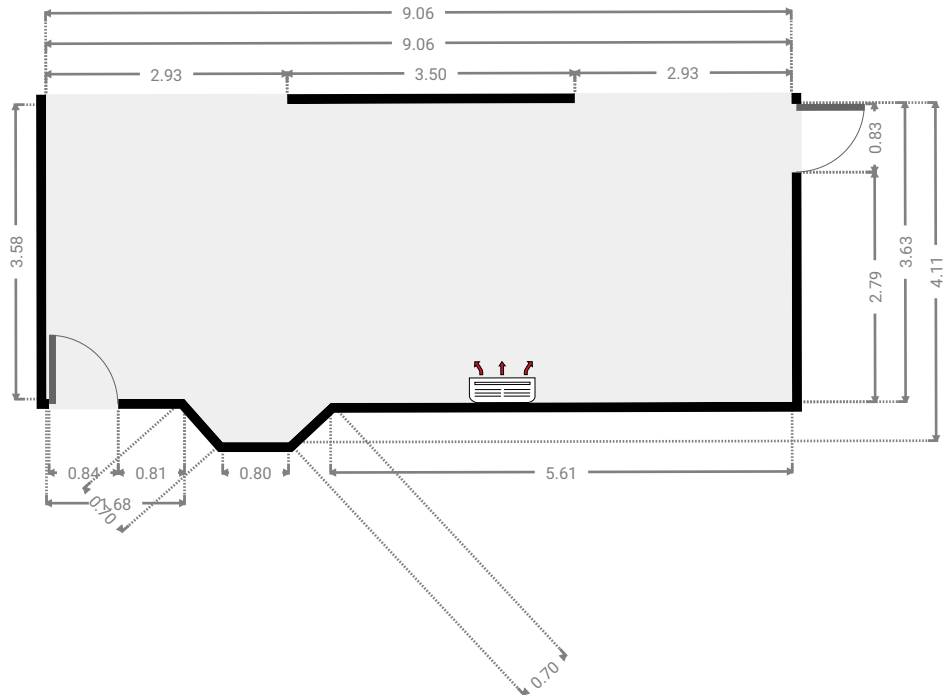
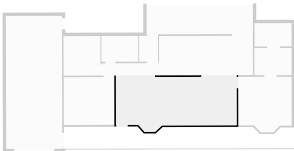

FLOORS: 1

▼ **Foyer**
Ground Floor

WIDTH: 10.00 m • LENGTH: 1.66 m • CEILING HEIGHT: 2.17 m
AREA: 15.74 m² • PERIMETER: 23.69 m

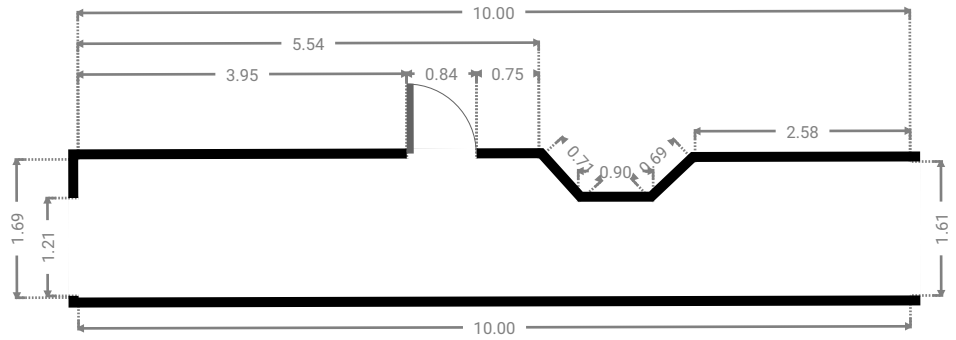
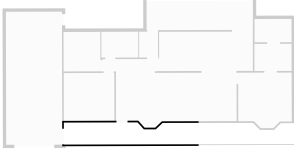

▼ **Foyer**
Ground Floor

WIDTH: 7.23 m • LENGTH: 1.61 m • CEILING HEIGHT: 2.17 m
AREA: 10.78 m² • PERIMETER: 18.08 m

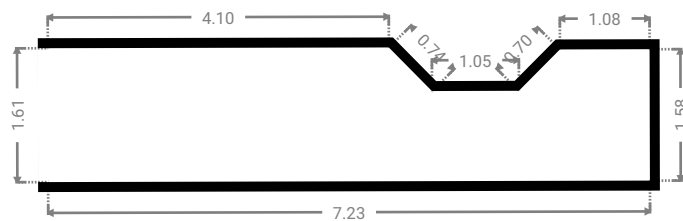
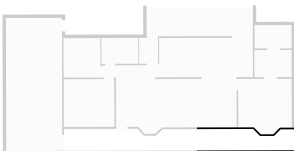

FLOORS: 1

▼ Garage
Ground Floor

WIDTH: 4.21 m • LENGTH: 9.99 m
AREA: 42.02 m² • PERIMETER: 28.39 m

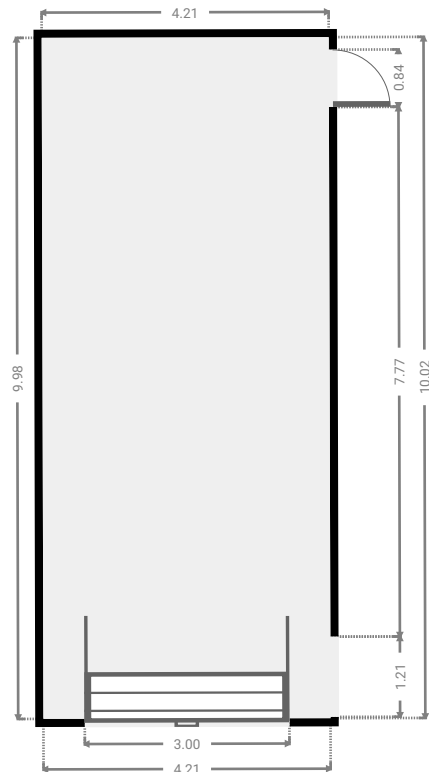

▼ Patio
Ground Floor

WIDTH: 7.98 m • LENGTH: 2.06 m
AREA: 16.42 m² • PERIMETER: 20.08 m

