

15 Bertram Street

SUBMITTED BY

Ray White Rockhampton Casey
stockers@cqoz.com

CREATED ON

2019-08-08

Floors

2

▼ Ground Floor

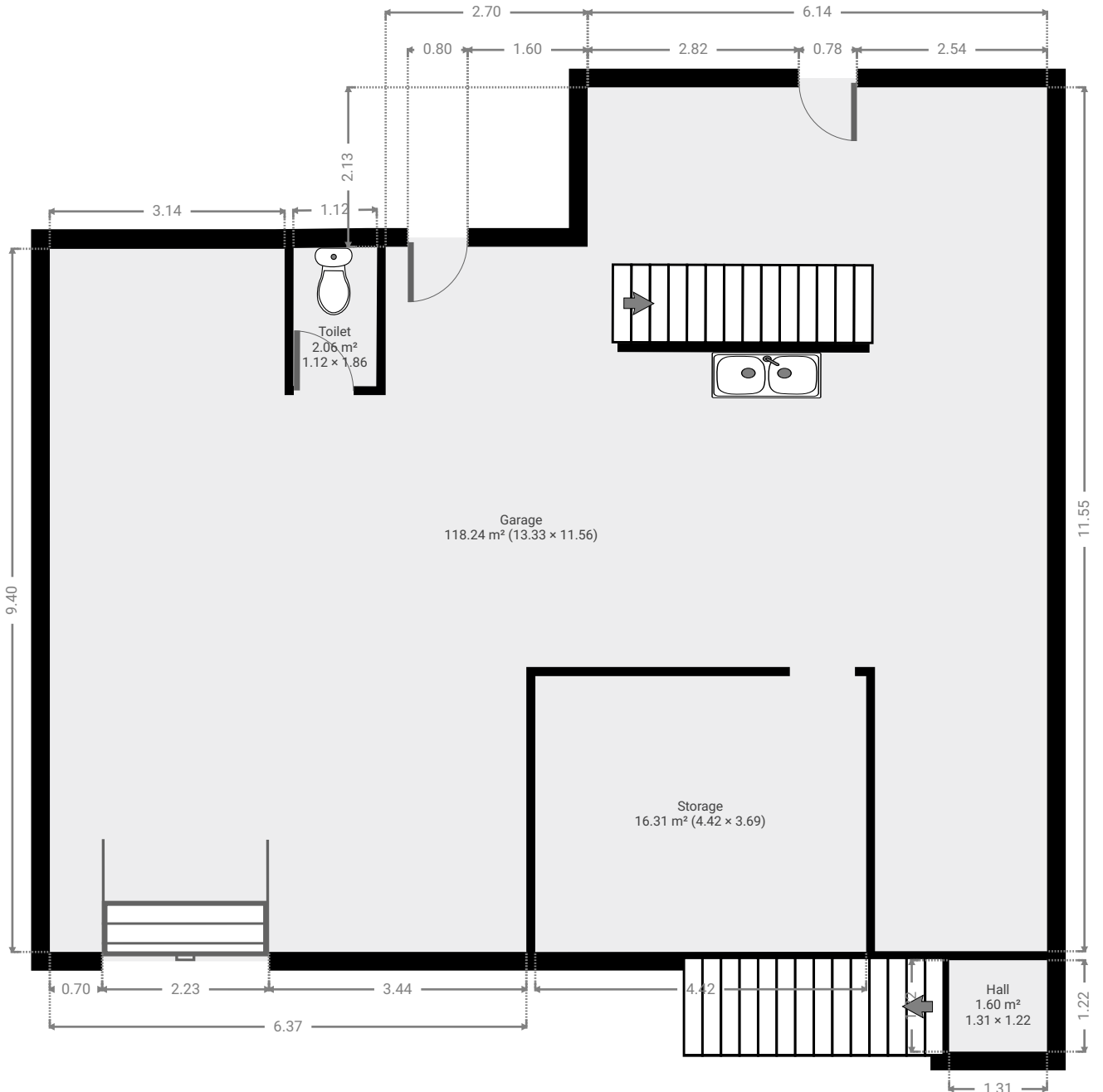

▼ **Garage**
Ground Floor

WIDTH: 13.33 m • LENGTH: 11.56 m
AREA: 118.24 m² • PERIMETER: 61.29 m

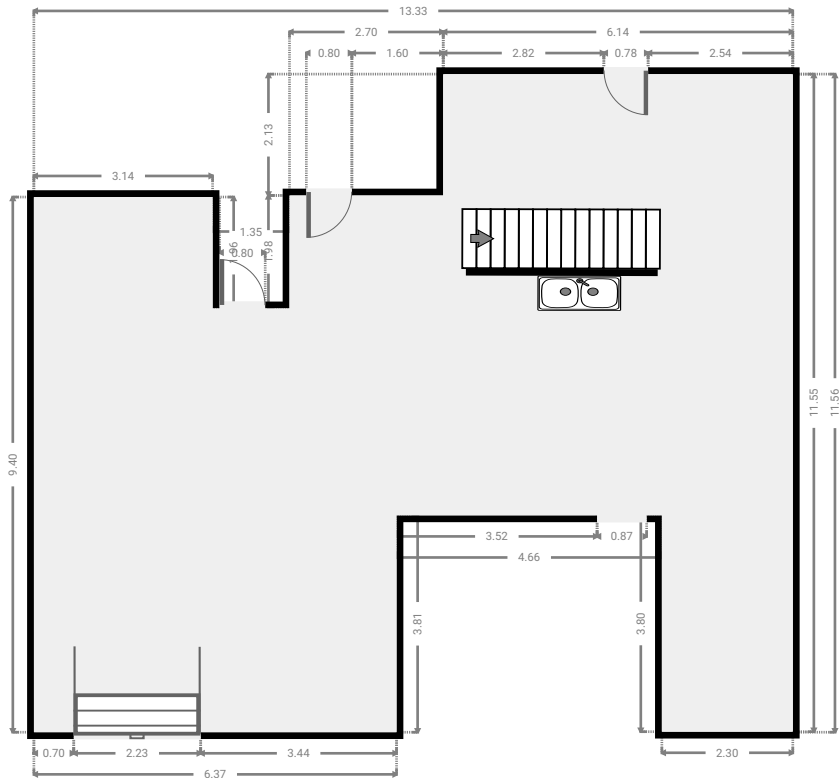
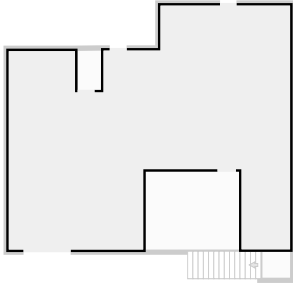

▼ **Storage**
Ground Floor

WIDTH: 4.42 m • LENGTH: 3.69 m
AREA: 16.31 m² • PERIMETER: 16.22 m

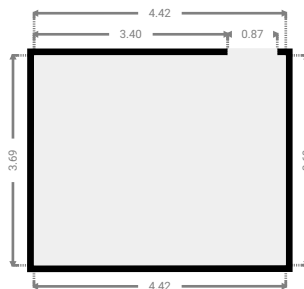
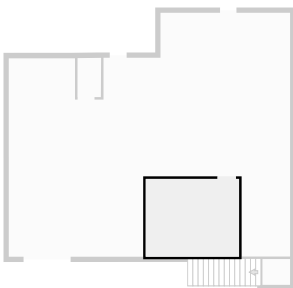

▼ **Toilet**
Ground Floor

WIDTH: 1.12 m • LENGTH: 1.86 m
AREA: 2.06 m² • PERIMETER: 5.93 m

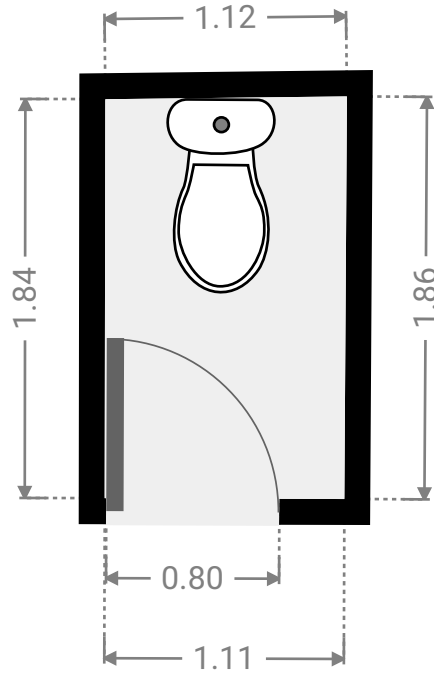
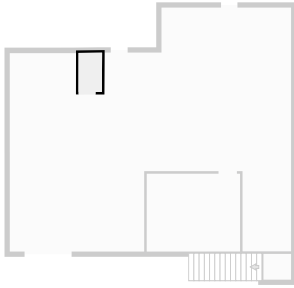

▼ **Hall**
Ground Floor

WIDTH: 1.31 m • LENGTH: 1.22 m
AREA: 1.60 m² • PERIMETER: 5.06 m

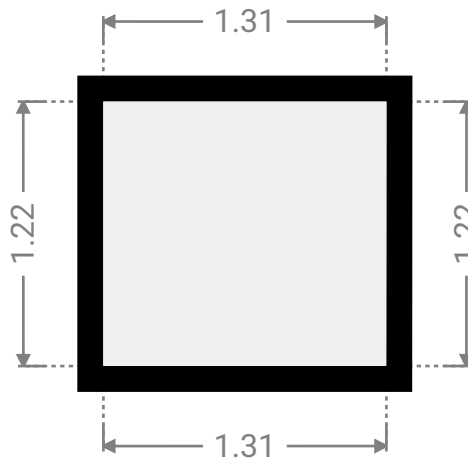
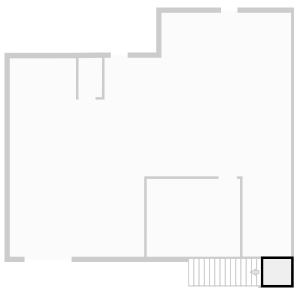

▼ 1st Floor



▼ Sunroom
1st Floor

WIDTH: 6.70 m • LENGTH: 1.66 m
AREA: 11.12 m² • PERIMETER: 16.72 m

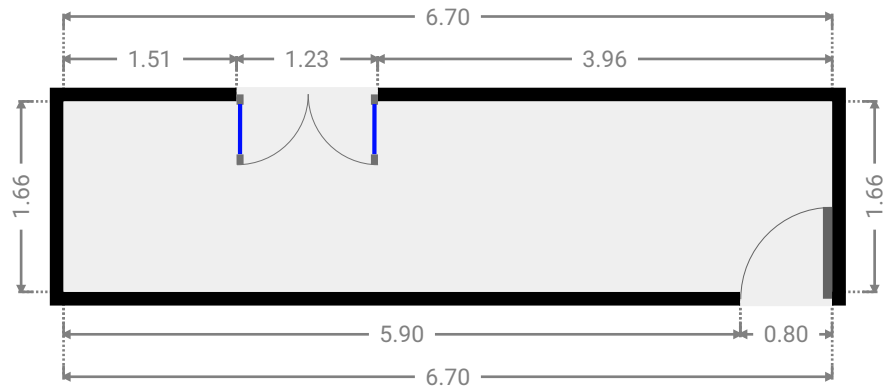
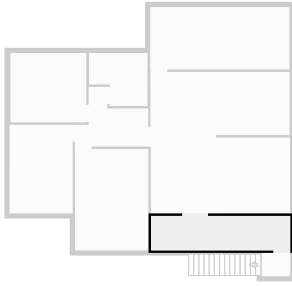

▼ Living Room
1st Floor

WIDTH: 6.70 m • LENGTH: 3.65 m
AREA: 24.46 m² • PERIMETER: 20.70 m

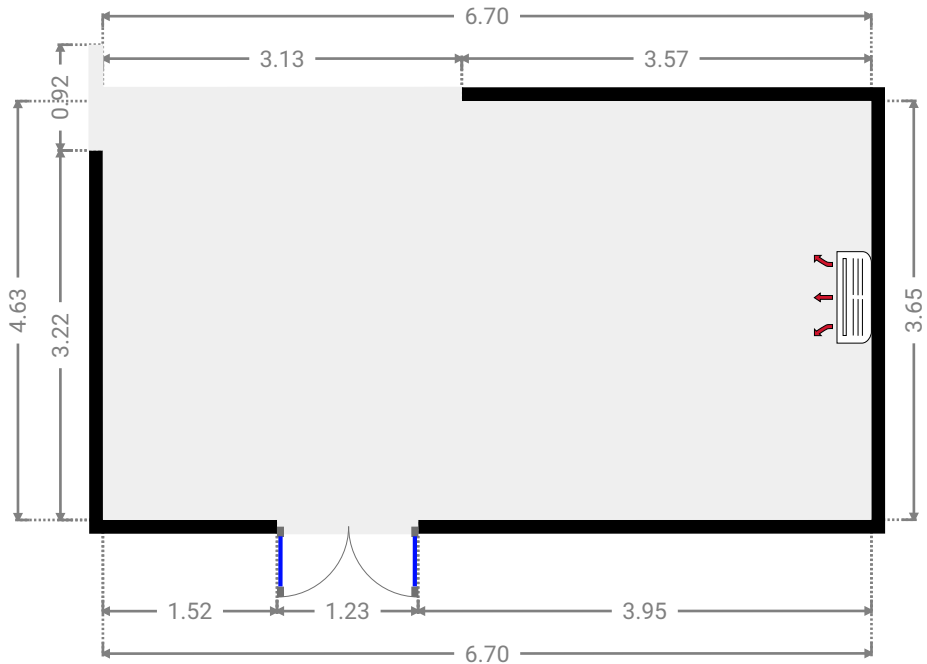
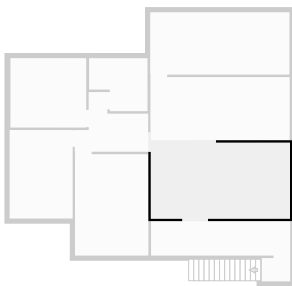

▼ **Kitchen**
1st Floor

WIDTH: 6.70 m • LENGTH: 3.04 m
AREA: 20.38 m² • PERIMETER: 19.48 m

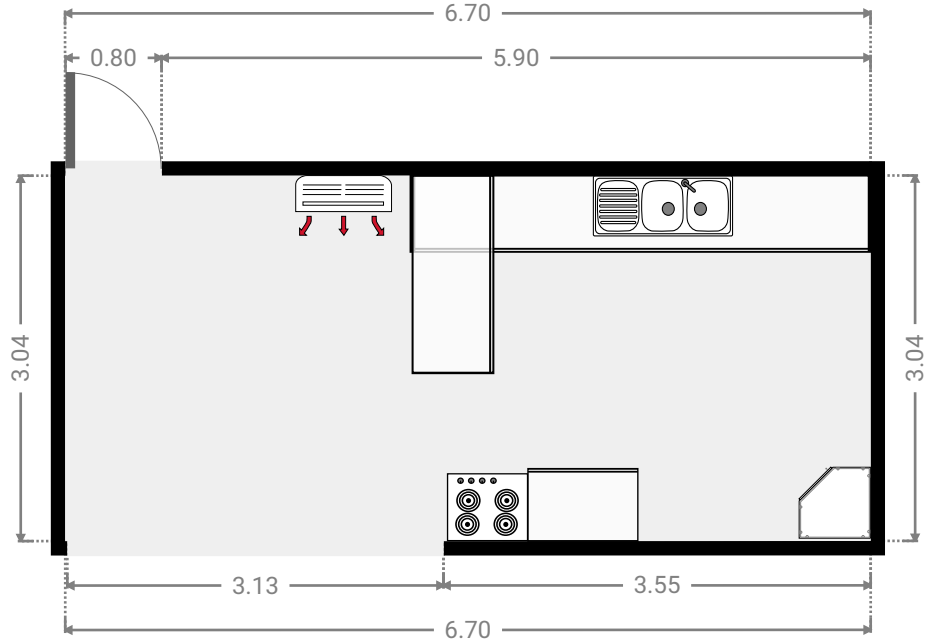

▼ **Stairway**
1st Floor

WIDTH: 6.70 m • LENGTH: 3.00 m
AREA: 20.11 m² • PERIMETER: 19.41 m

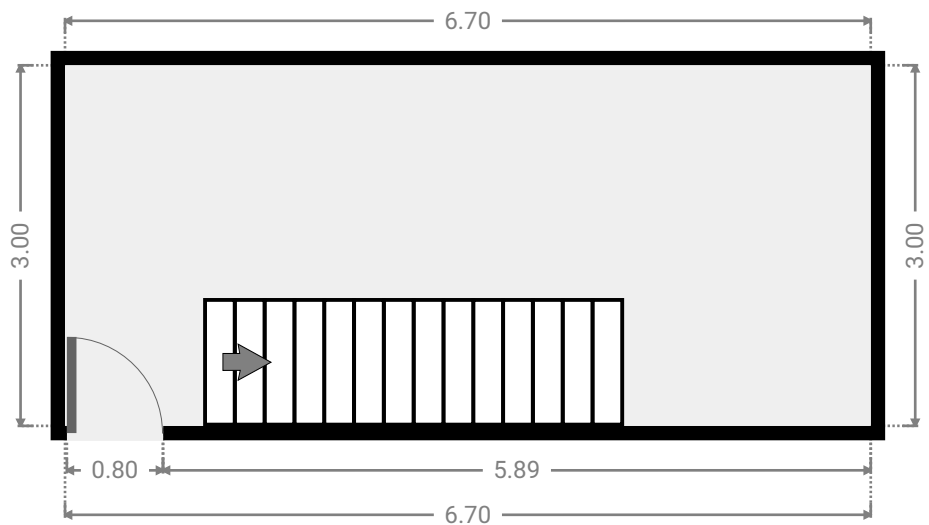
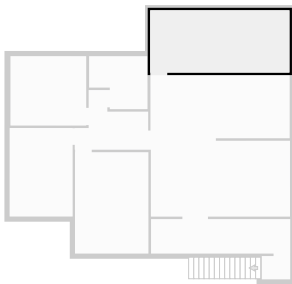

▼ **Hall**
1st Floor

WIDTH: 3.53 m • LENGTH: 2.87 m
AREA: 6.88 m² • PERIMETER: 12.81 m

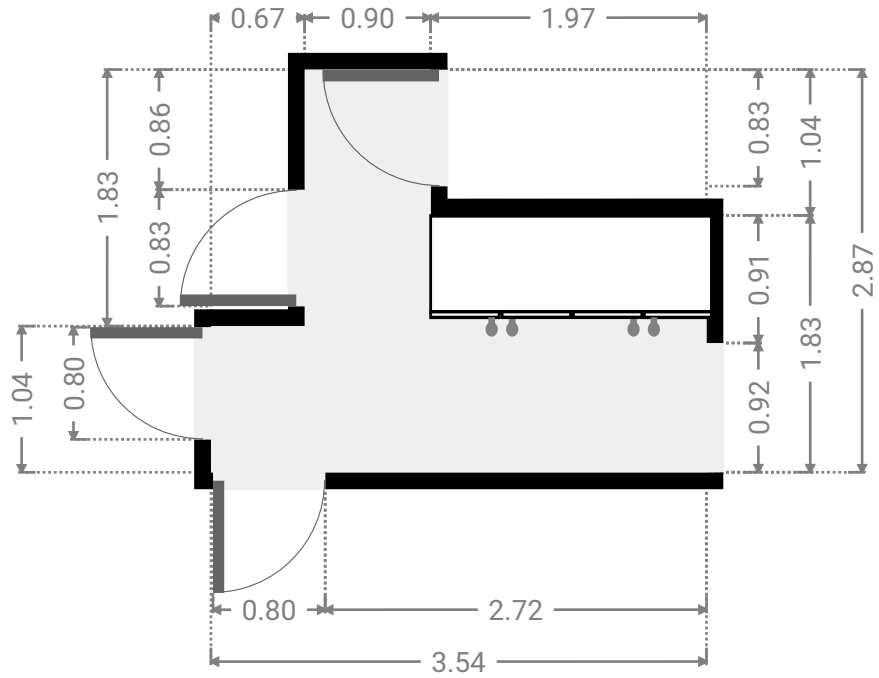
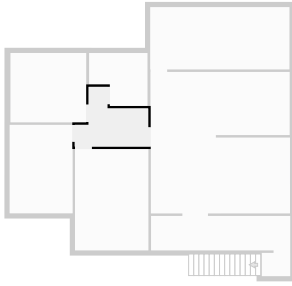

▼ **Bedroom**
1st Floor

WIDTH: 3.03 m • LENGTH: 4.26 m
AREA: 12.92 m² • PERIMETER: 14.58 m

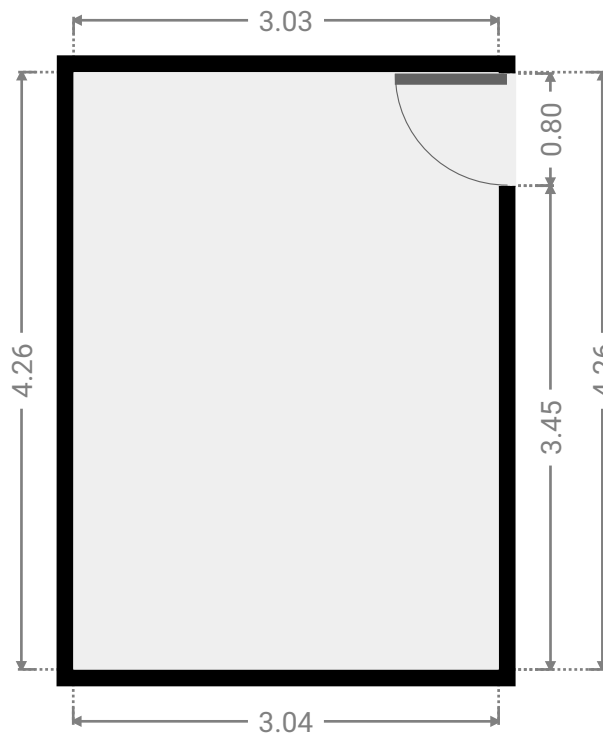
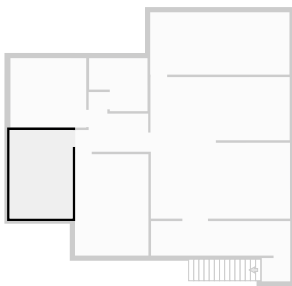

▼ **Bedroom**
1st Floor

WIDTH: 3.53 m • LENGTH: 4.88 m
AREA: 17.25 m² • PERIMETER: 16.83 m

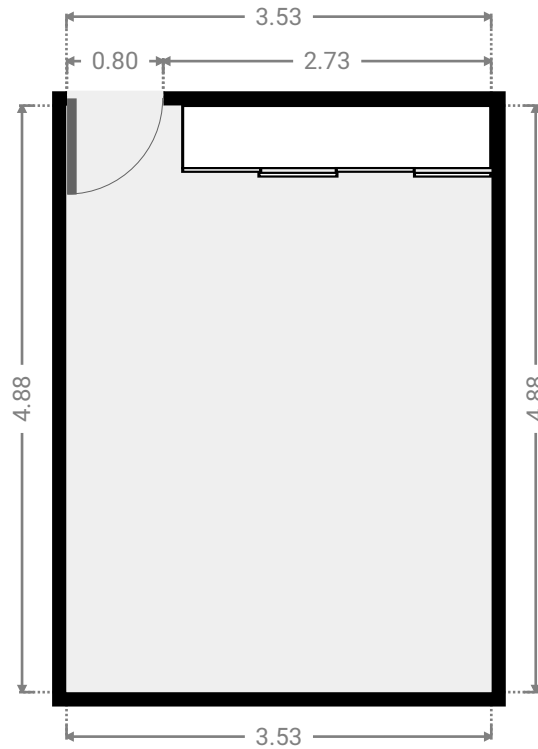
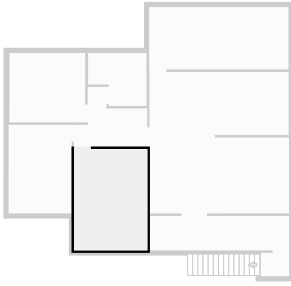

▼ **Bedroom**
1st Floor

WIDTH: 3.65 m • LENGTH: 3.34 m
AREA: 12.18 m² • PERIMETER: 13.97 m

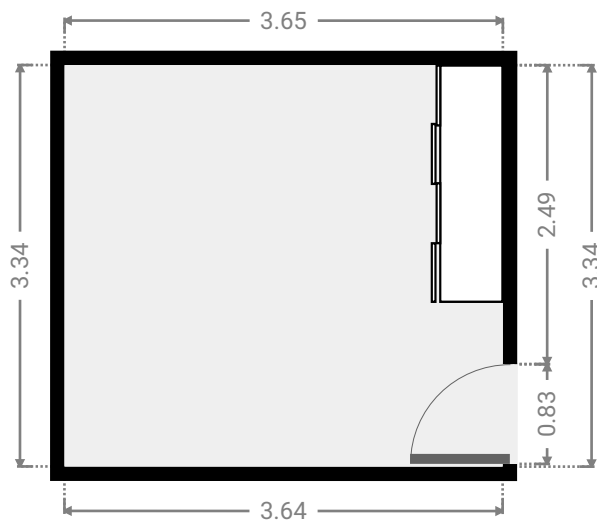
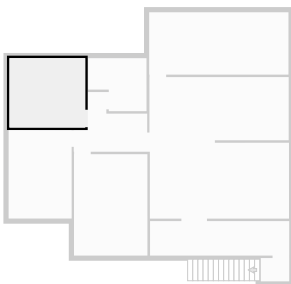

▼ **Bathroom**
1st Floor

WIDTH: 2.81 m • LENGTH: 2.55 m
AREA: 6.13 m² • PERIMETER: 10.72 m

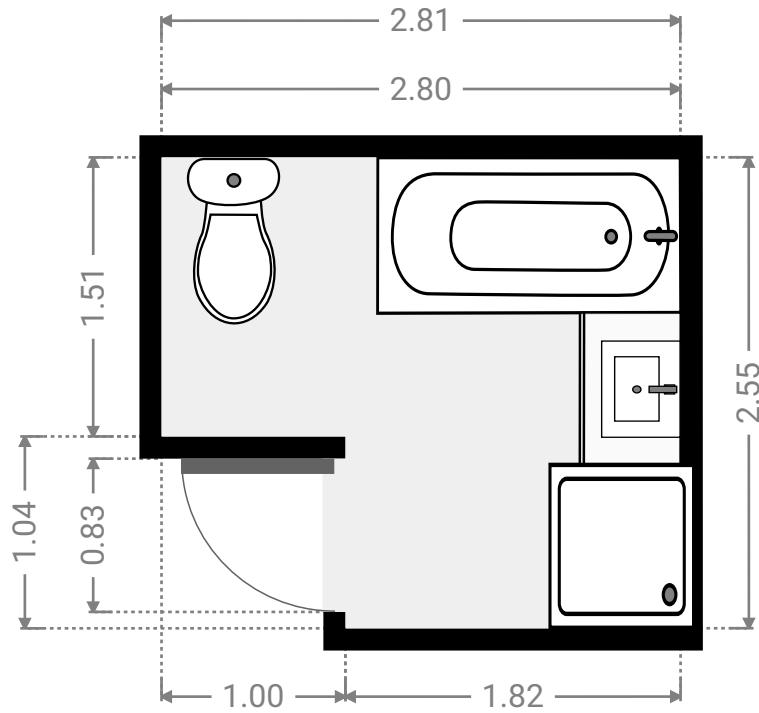
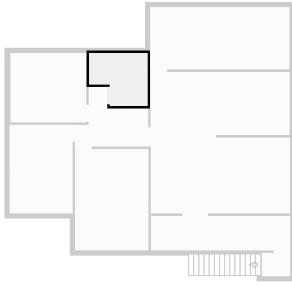

▼ **Hall**
1st Floor

WIDTH: 1.37 m • LENGTH: 1.12 m
AREA: 1.54 m² • PERIMETER: 4.98 m

