

148 Murray Street

SUBMITTED BY

Ray White Rockhampton Casey
stockers@cqoz.com

CREATED ON

2021-11-30

Floors

2

▼ Ground Floor

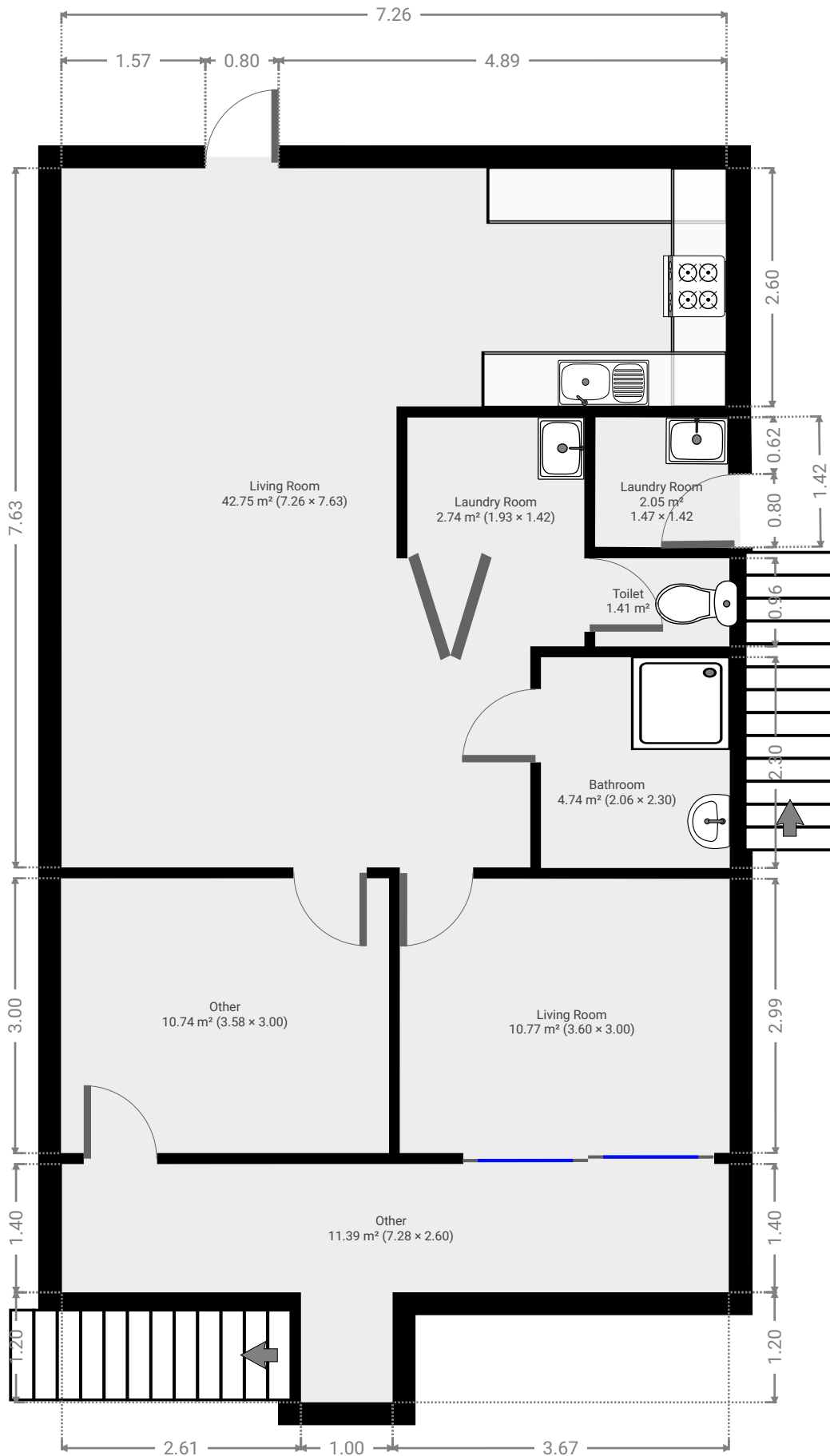

▼ **Other**
Ground Floor

WIDTH: 3.58 m • LENGTH: 3.00 m
AREA: 10.74 m² • PERIMETER: 13.16 m

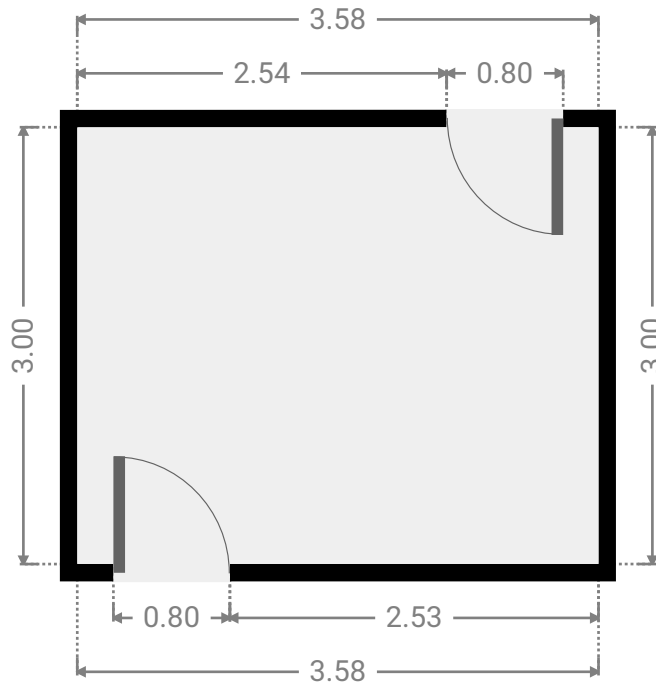
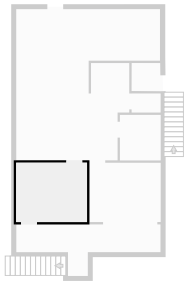

▼ **Living Room**
Ground Floor

WIDTH: 3.60 m • LENGTH: 2.99 m
AREA: 10.77 m² • PERIMETER: 13.19 m

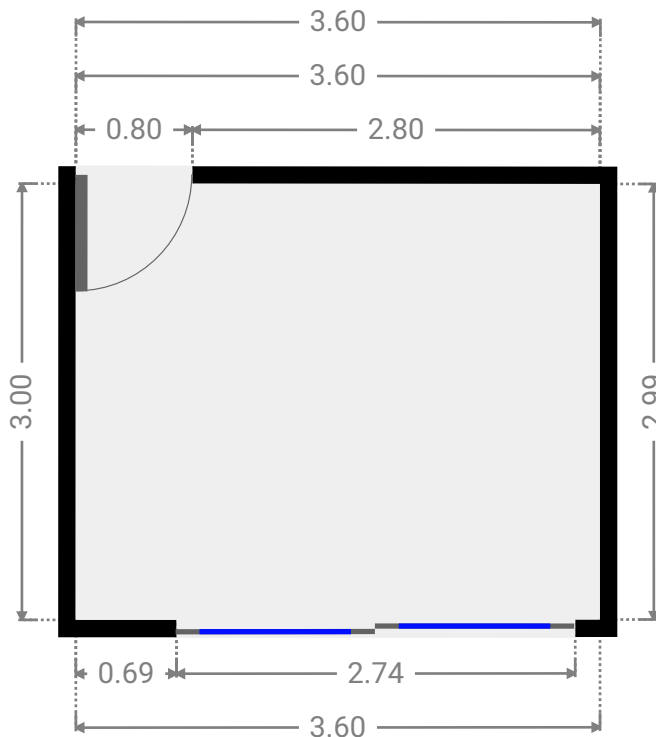
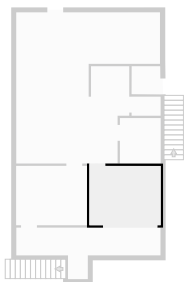

▼ Bathroom
Ground Floor

WIDTH: 2.06 m • LENGTH: 2.30 m
AREA: 4.74 m² • PERIMETER: 8.72 m

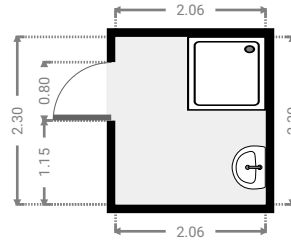
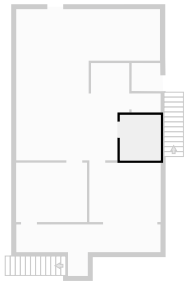

▼ Living Room
Ground Floor

WIDTH: 7.28 m • LENGTH: 7.63 m
AREA: 42.75 m² • PERIMETER: 33.87 m

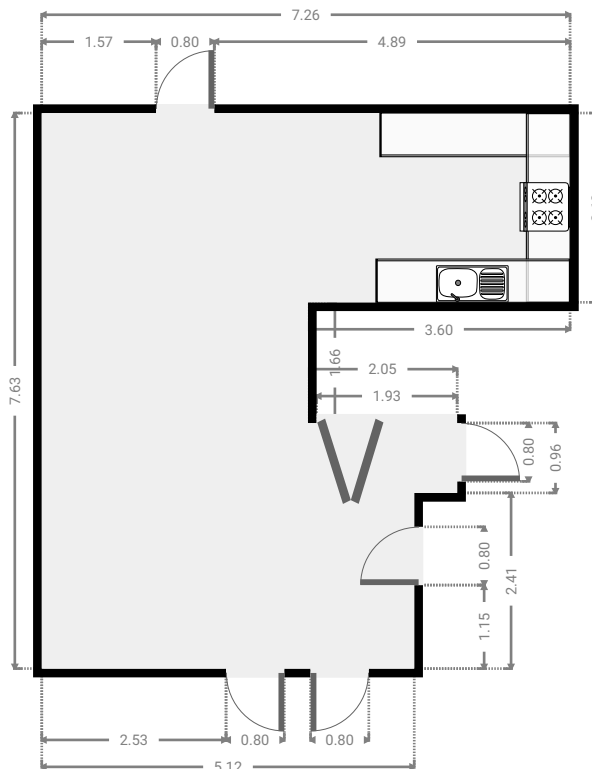
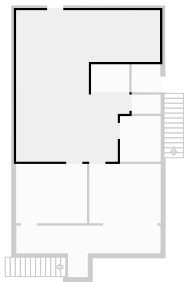

▼ **Laundry Room**
Ground Floor

WIDTH: 1.93 m • LENGTH: 1.42 m
AREA: 2.74 m² • PERIMETER: 6.70 m

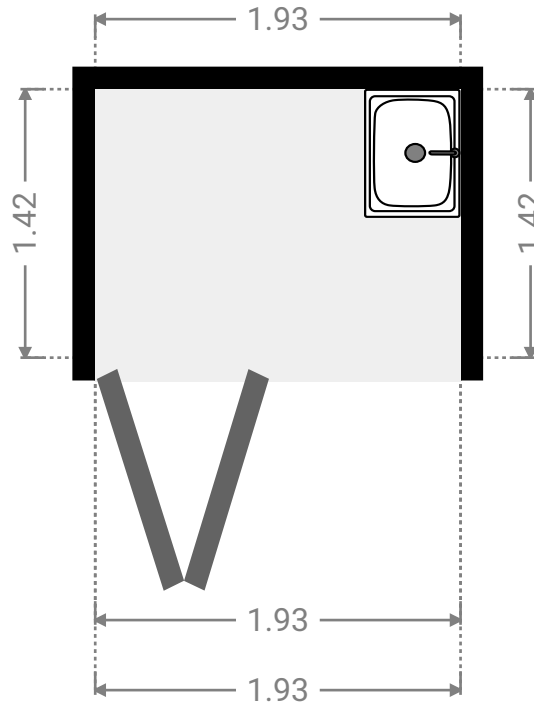

▼ **Toilet**
Ground Floor

WIDTH: 1.47 m • LENGTH: 0.96 m
AREA: 1.41 m² • PERIMETER: 4.85 m

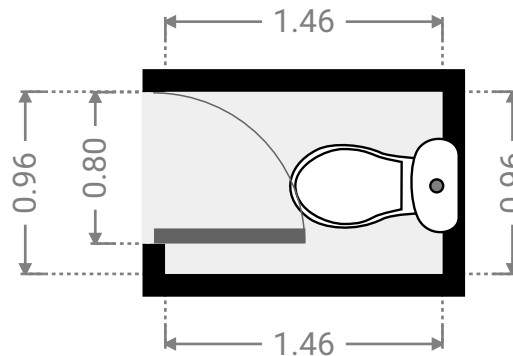

▼ Laundry Room
Ground Floor

WIDTH: 1.47 m • LENGTH: 1.42 m
AREA: 2.05 m² • PERIMETER: 5.73 m

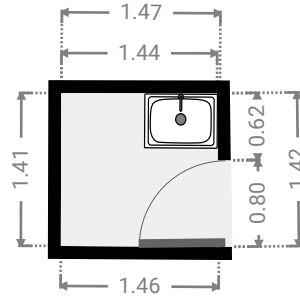

▼ Other
Ground Floor

WIDTH: 7.28 m • LENGTH: 2.60 m
AREA: 11.39 m² • PERIMETER: 19.76 m

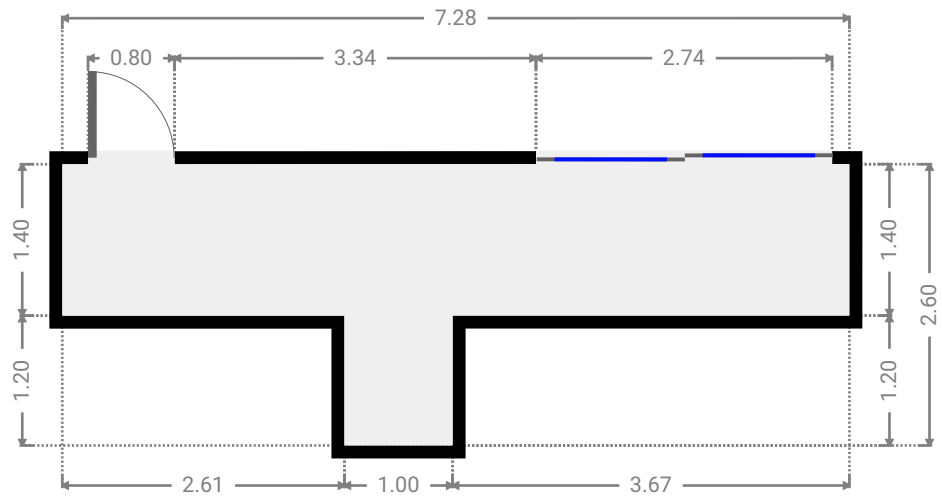
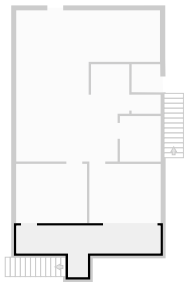

▼ 1st Floor

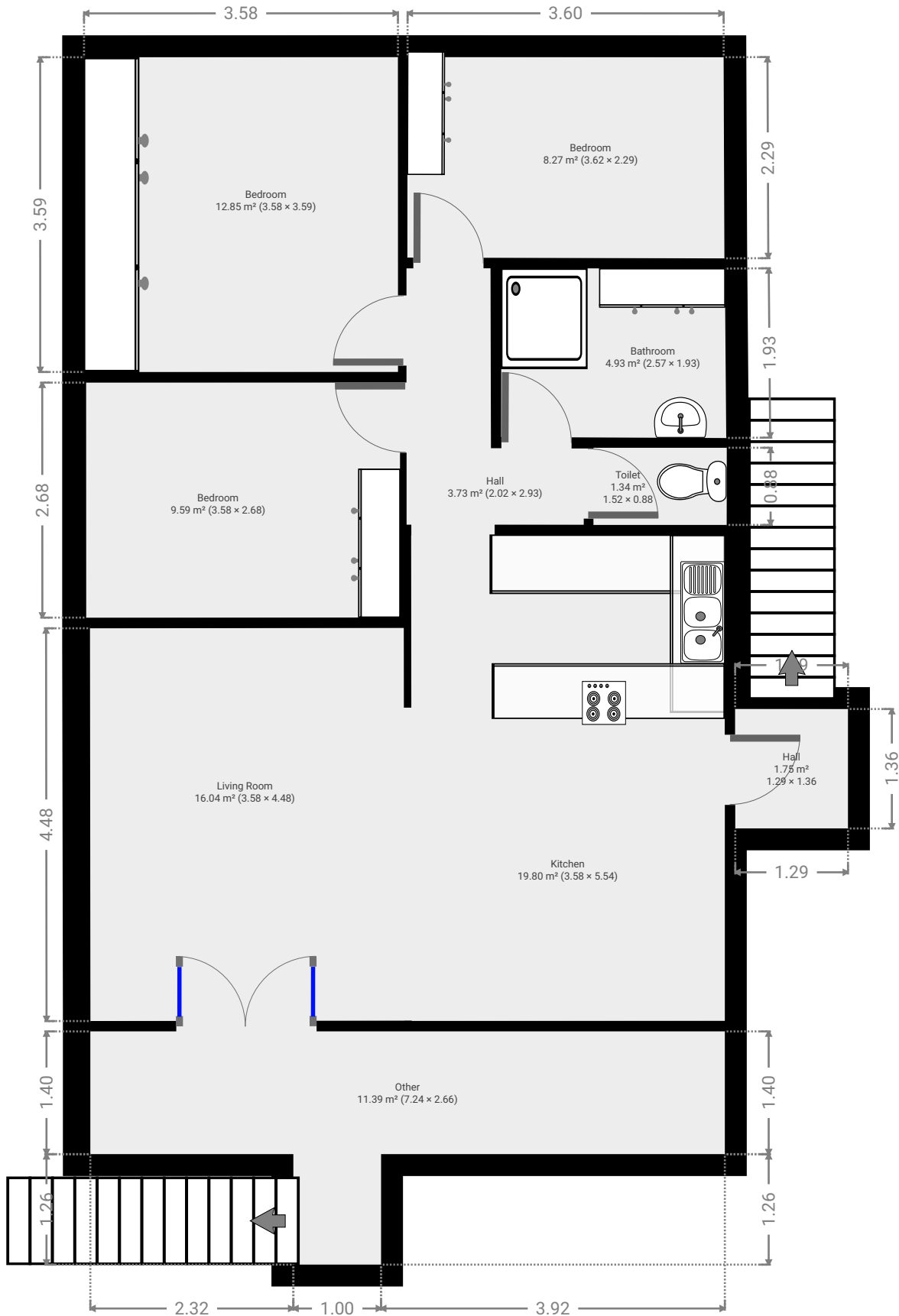

▼ Living Room
1st Floor

WIDTH: 3.58 m • LENGTH: 4.48 m
AREA: 16.04 m² • PERIMETER: 16.12 m

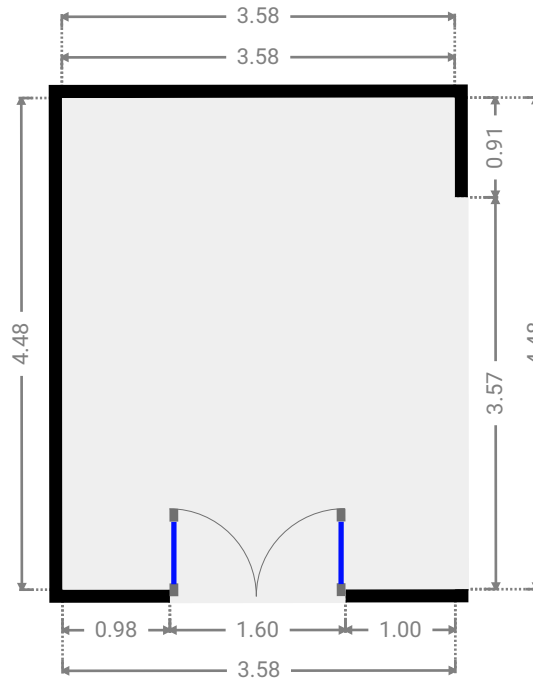

▼ Kitchen
1st Floor

WIDTH: 3.58 m • LENGTH: 5.54 m
AREA: 19.80 m² • PERIMETER: 18.23 m

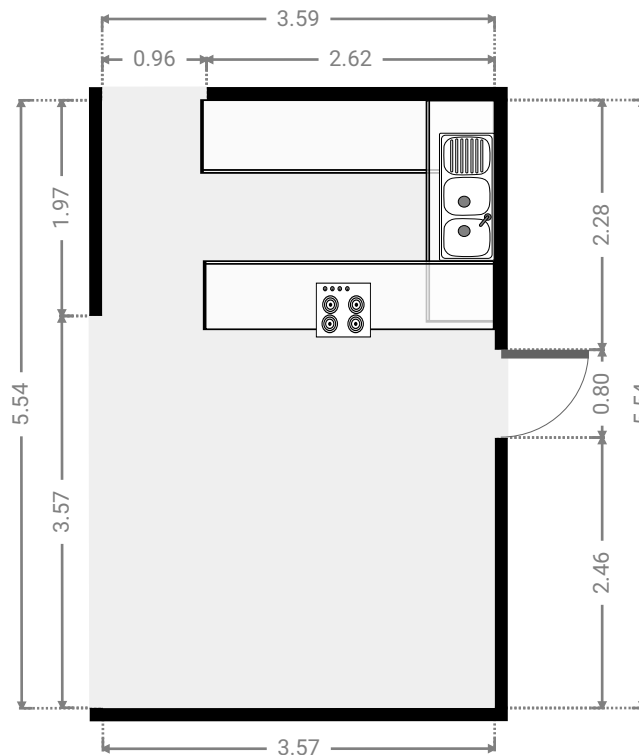
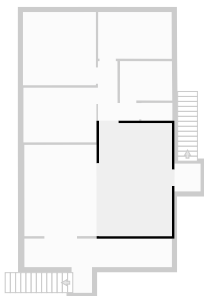

▼ **Hall**
1st Floor

WIDTH: 2.02 m • LENGTH: 2.93 m
AREA: 3.73 m² • PERIMETER: 9.88 m

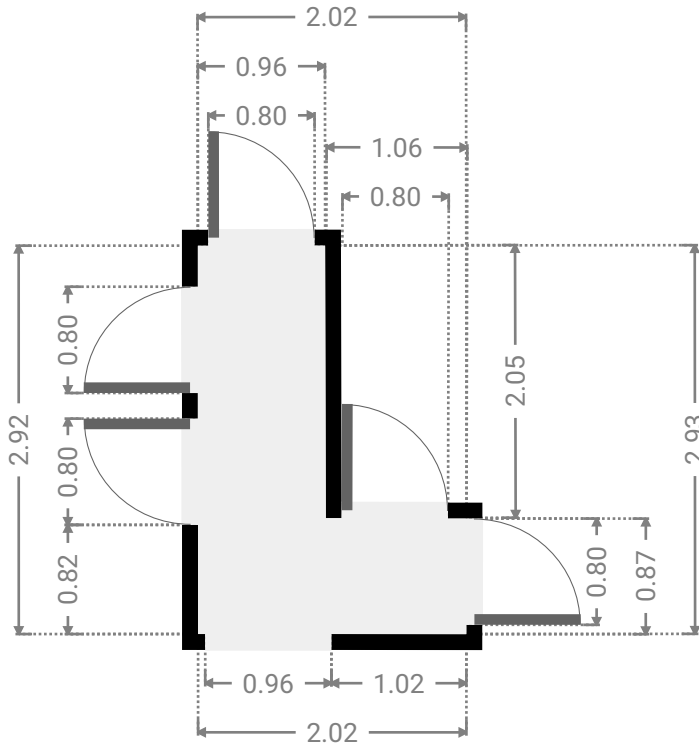

▼ **Toilet**
1st Floor

WIDTH: 1.52 m • LENGTH: 0.88 m
AREA: 1.34 m² • PERIMETER: 4.80 m

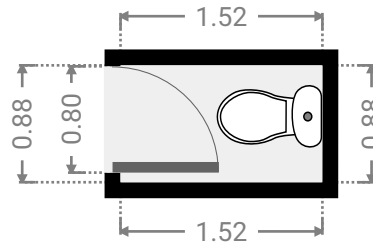

▼ Bathroom
1st Floor

WIDTH: 2.57 m • LENGTH: 1.93 m
AREA: 4.93 m² • PERIMETER: 8.97 m

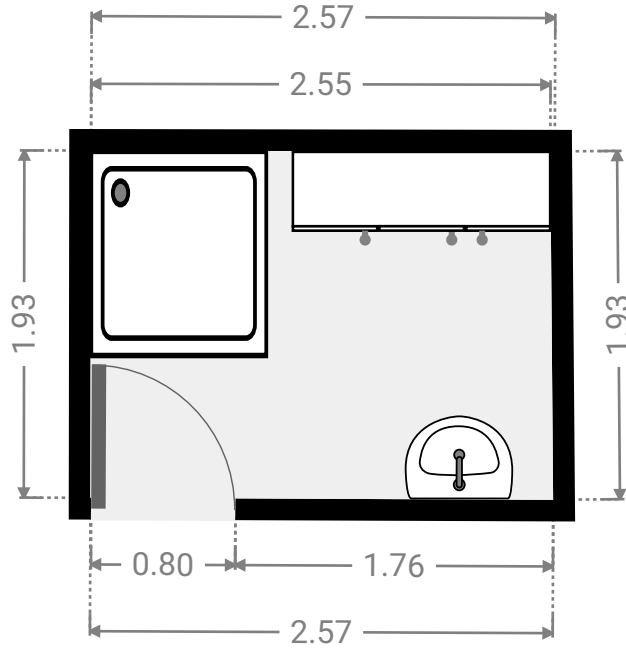

▼ Bedroom
1st Floor

WIDTH: 3.58 m • LENGTH: 2.68 m
AREA: 9.59 m² • PERIMETER: 12.52 m

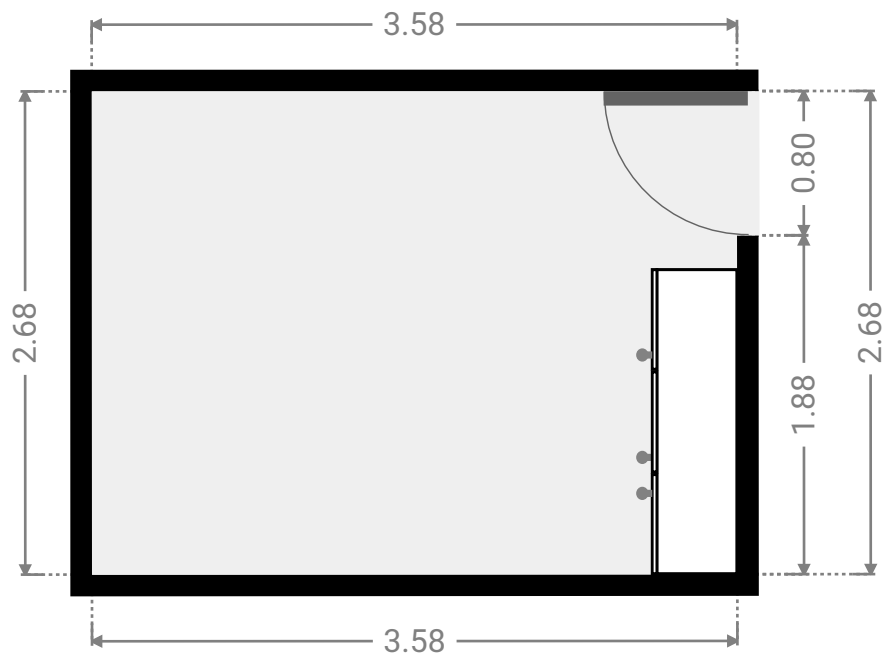
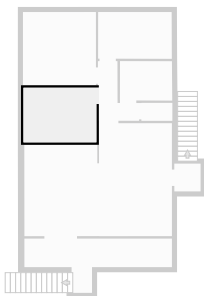

▼ **Bedroom**
1st Floor

WIDTH: 3.58 m • LENGTH: 3.59 m
AREA: 12.85 m² • PERIMETER: 14.34 m

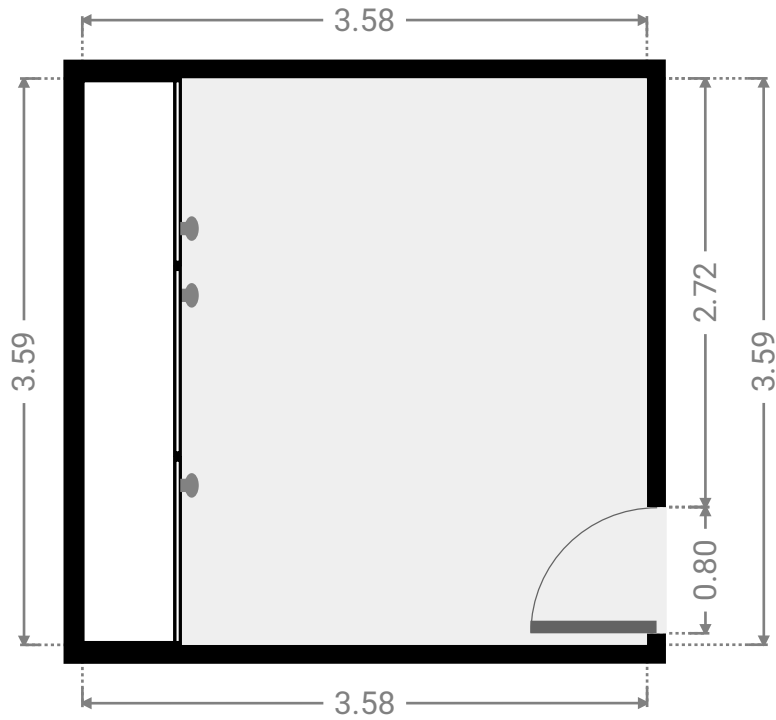

▼ **Bedroom**
1st Floor

WIDTH: 3.62 m • LENGTH: 2.29 m
AREA: 8.27 m² • PERIMETER: 11.80 m

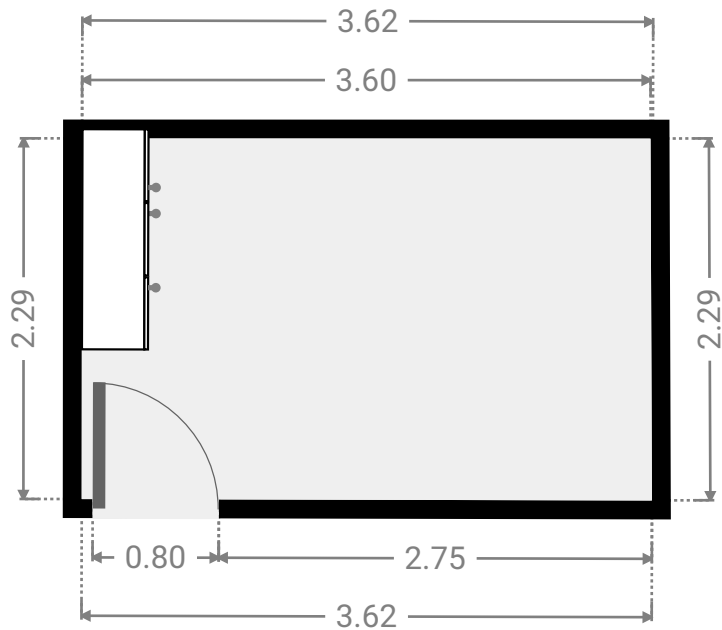

▼ **Hall**
1st Floor

WIDTH: 1.29 m • LENGTH: 1.36 m
AREA: 1.75 m² • PERIMETER: 5.30 m

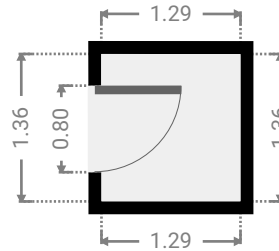
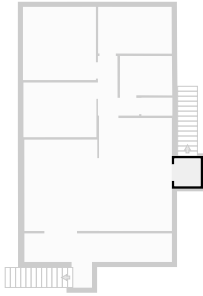

▼ **Other**
1st Floor

WIDTH: 7.24 m • LENGTH: 2.66 m
AREA: 11.39 m² • PERIMETER: 19.79 m

