

148 Donnalén Street

SUBMITTED BY

Ray White Rockhampton Casey
stockers@cqoz.com

CREATED ON

2022-12-01

Floors

2

▼ Ground Floor

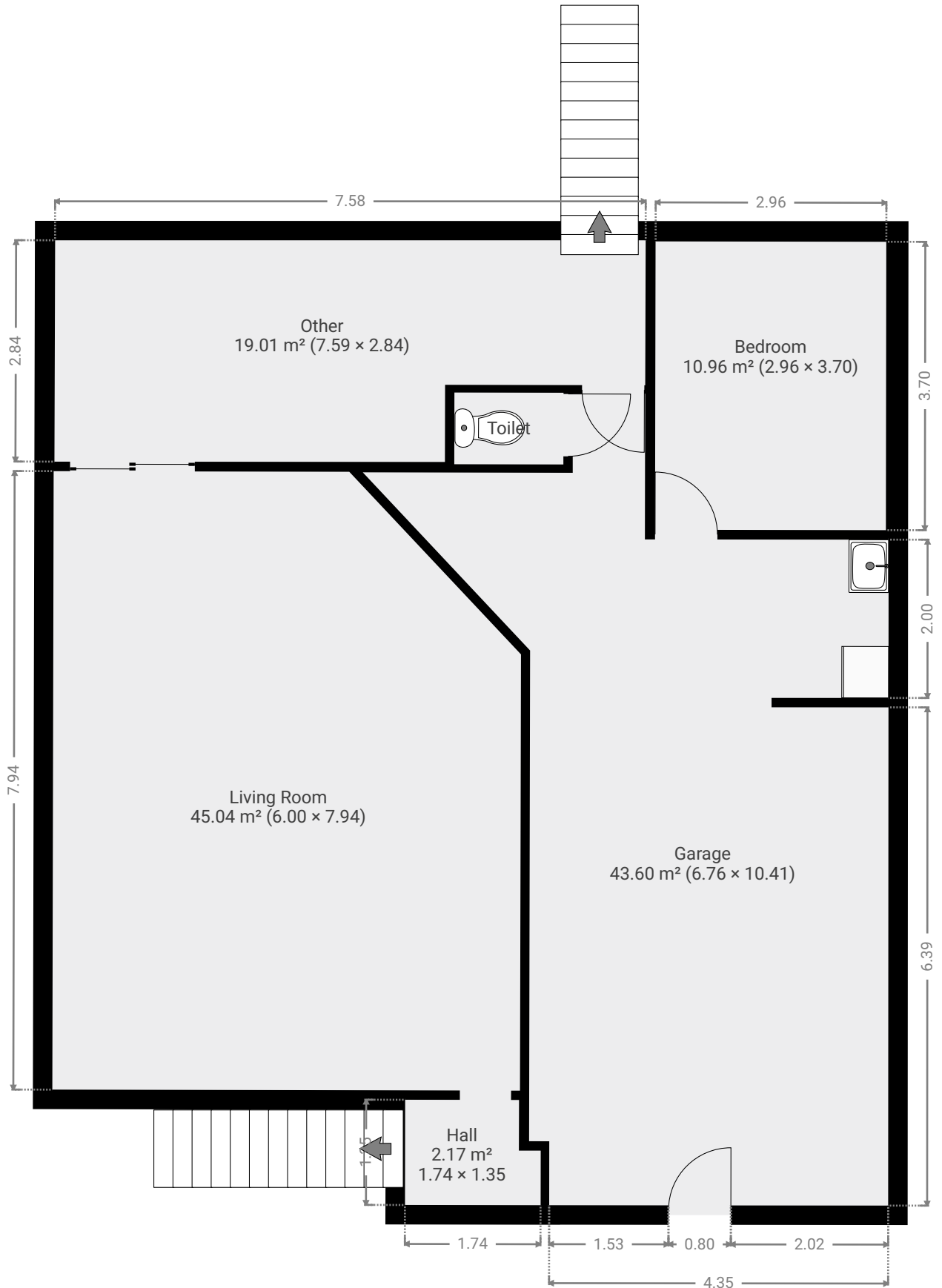

FLOORS: 2

▼ **Bedroom**
Ground Floor

WIDTH: 2.96 m • LENGTH: 3.70 m
AREA: 10.96 m² • PERIMETER: 13.32 m

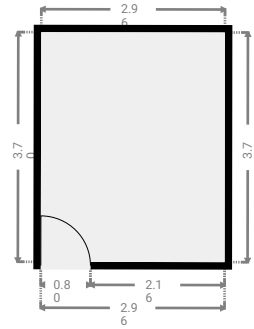
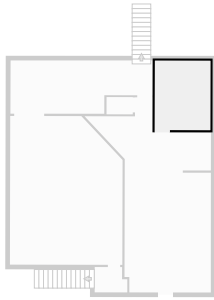

▼ **Garage**
Ground Floor

WIDTH: 6.76 m • LENGTH: 10.41 m
AREA: 43.60 m² • PERIMETER: 36.04 m

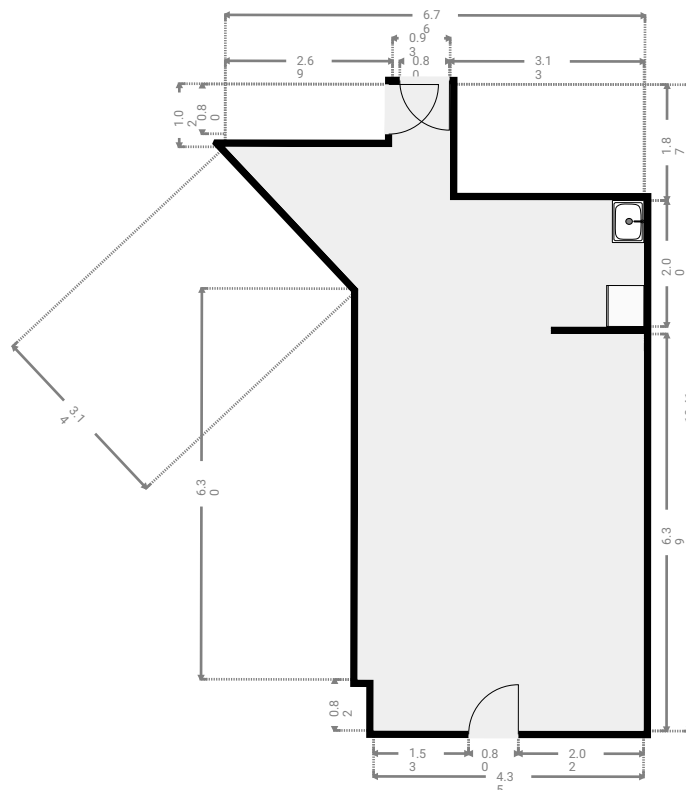
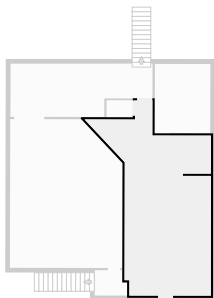

FLOORS: 2

▼ **Hall**
Ground Floor

WIDTH: 1.74 m • LENGTH: 1.35 m
AREA: 2.17 m² • PERIMETER: 6.18 m

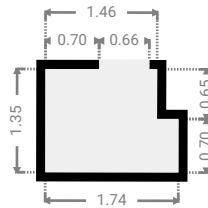
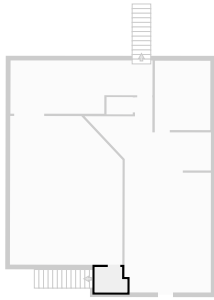

▼ **Living Room**
Ground Floor

WIDTH: 6.00 m • LENGTH: 7.94 m
AREA: 45.04 m² • PERIMETER: 26.54 m

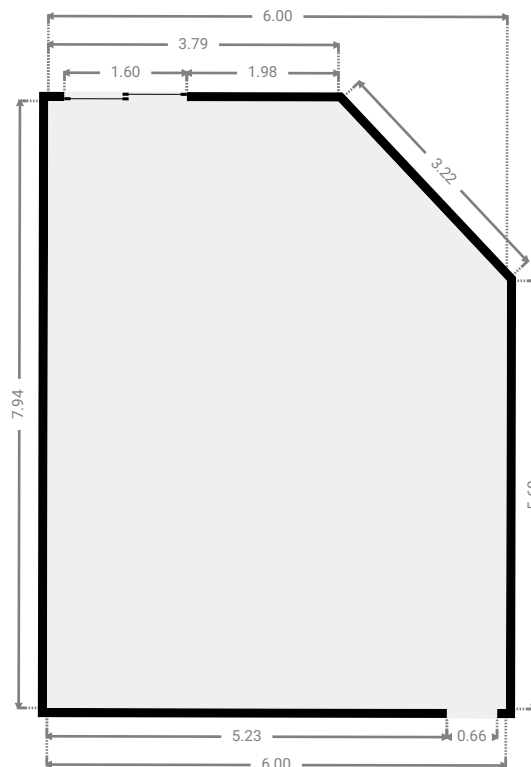
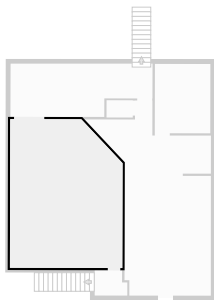

▼ **Other**
Ground Floor

WIDTH: 7.59 m • LENGTH: 2.84 m
AREA: 19.01 m² • PERIMETER: 20.85 m

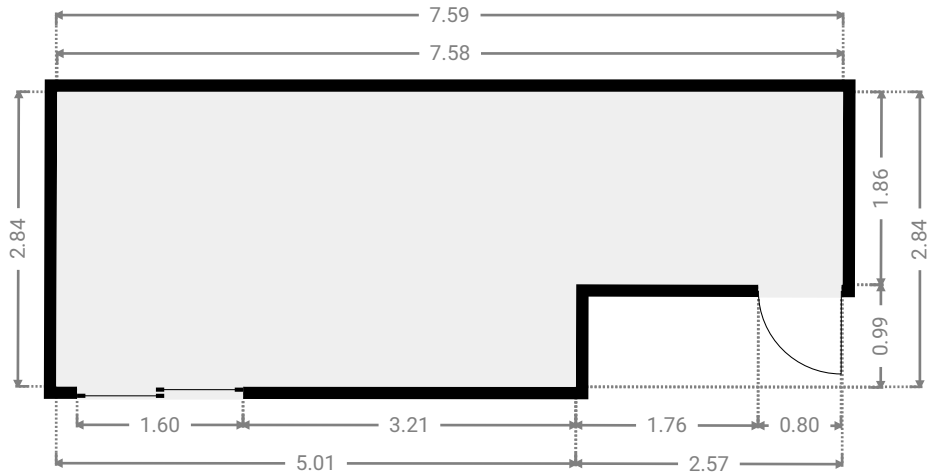
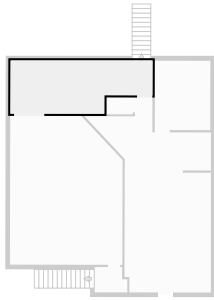

▼ **Toilet**
Ground Floor

WIDTH: 1.40 m • LENGTH: 0.92 m
AREA: 1.29 m² • PERIMETER: 4.64 m

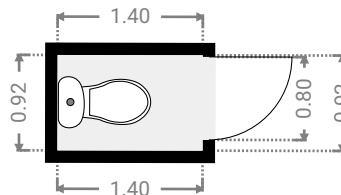
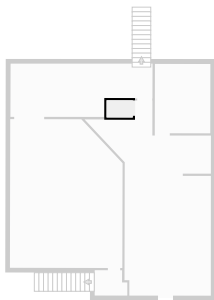

▼ 1st Floor

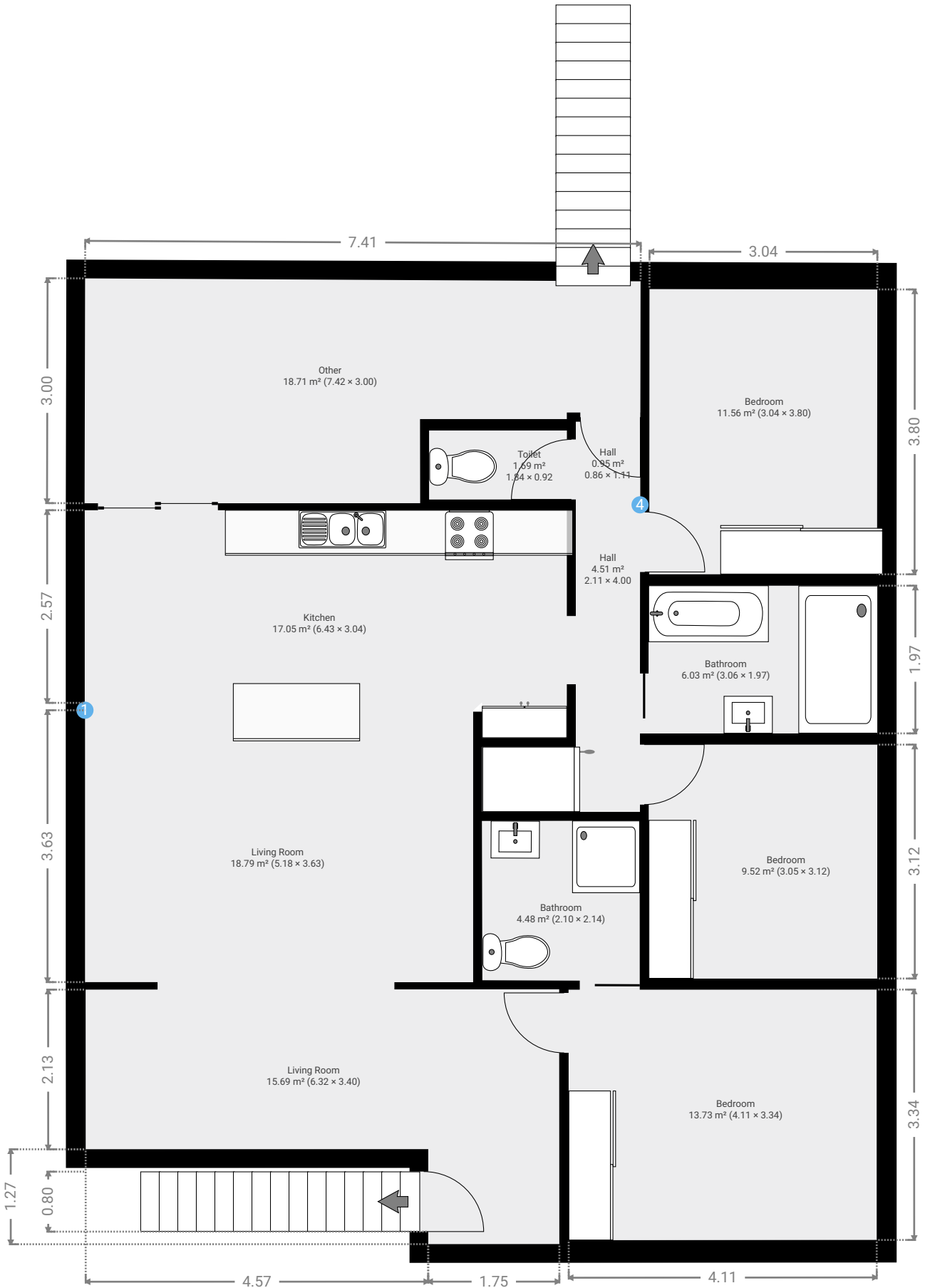

THIS FLOORPLAN IS PROVIDED WITHOUT WARRANTY OF ANY KIND. SENSOPIA DISCLAIMS ANY WARRANTY INCLUDING, WITHOUT LIMITATION, SATISFACTORY QUALITY OR ACCURACY OF DIMENSIONS.

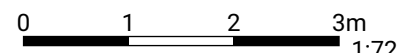

▼ **Bathroom**
1st Floor

WIDTH: 3.06 m • LENGTH: 1.97 m
AREA: 6.03 m² • PERIMETER: 10.06 m

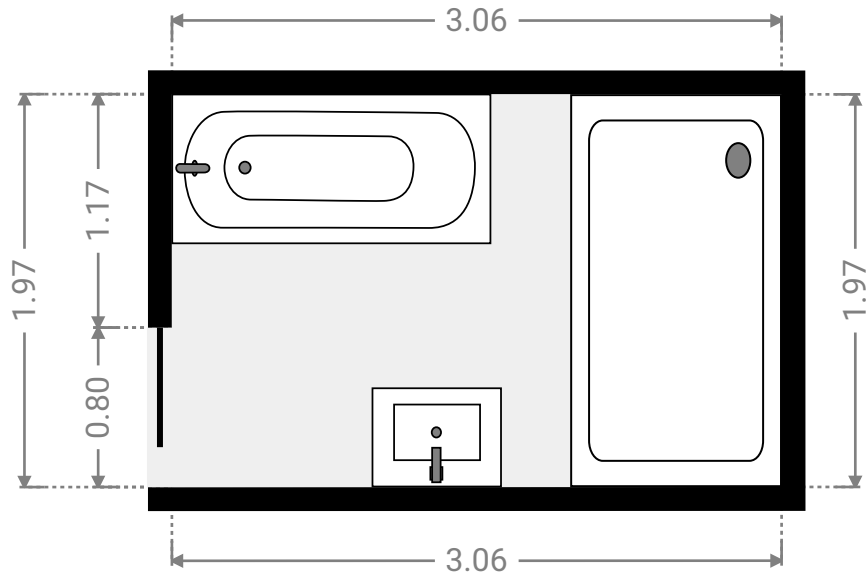
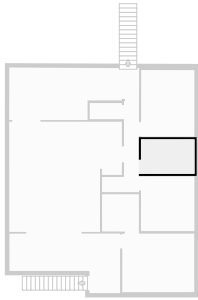

▼ **Bathroom**
1st Floor

WIDTH: 2.10 m • LENGTH: 2.14 m
AREA: 4.48 m² • PERIMETER: 8.46 m

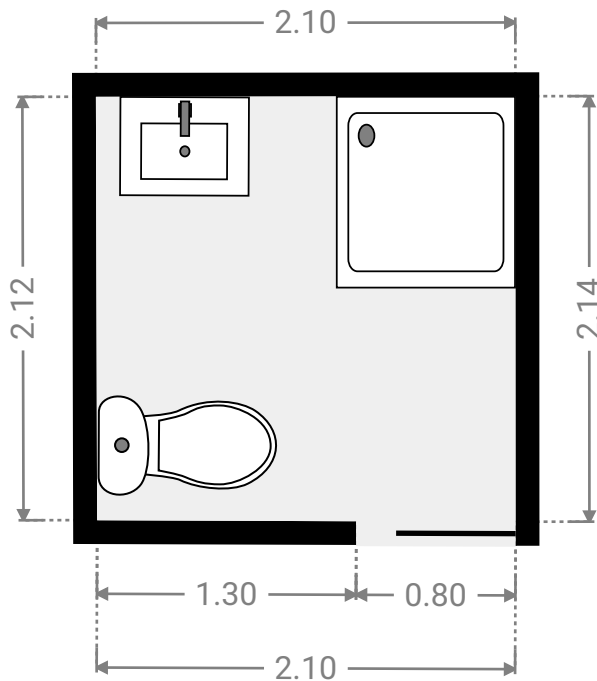
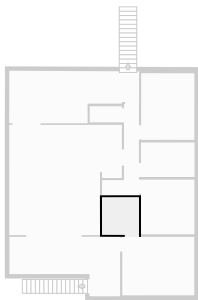

▼ **Bedroom**
1st Floor

WIDTH: 3.05 m • LENGTH: 3.12 m
AREA: 9.52 m² • PERIMETER: 12.34 m

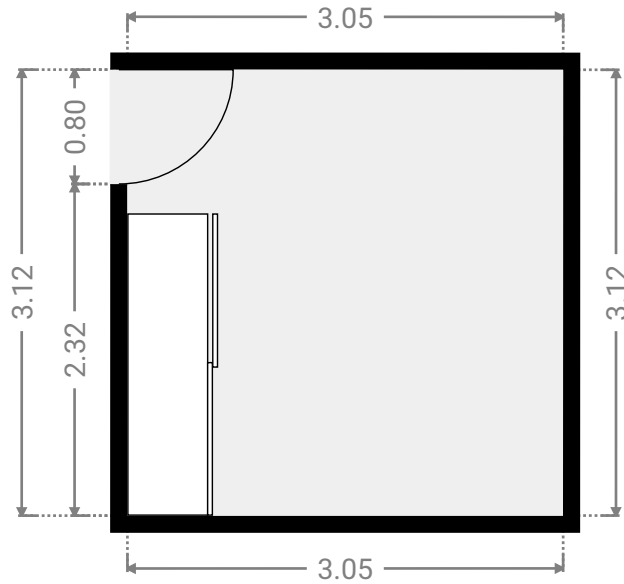

▼ **Bedroom**
1st Floor

WIDTH: 3.04 m • LENGTH: 3.80 m
AREA: 11.56 m² • PERIMETER: 13.68 m

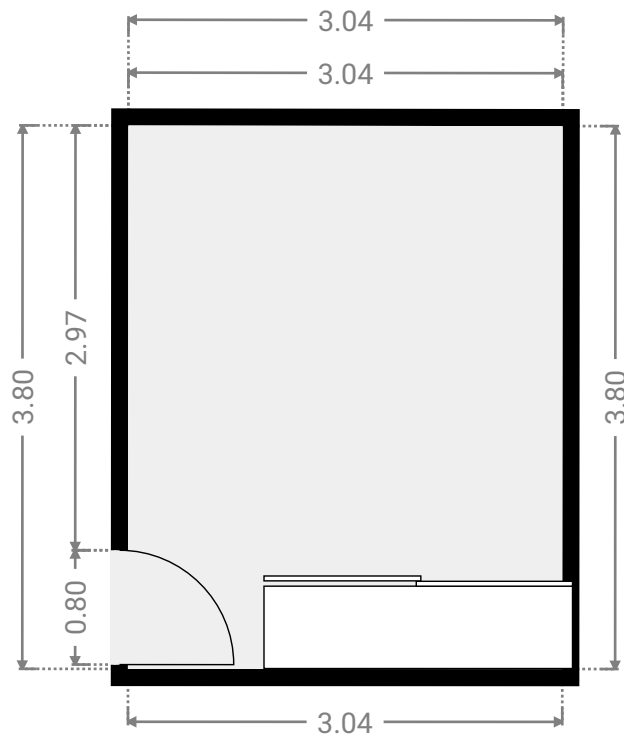

▼ **Bedroom**
1st Floor

WIDTH: 4.11 m • LENGTH: 3.34 m
AREA: 13.73 m² • PERIMETER: 14.90 m

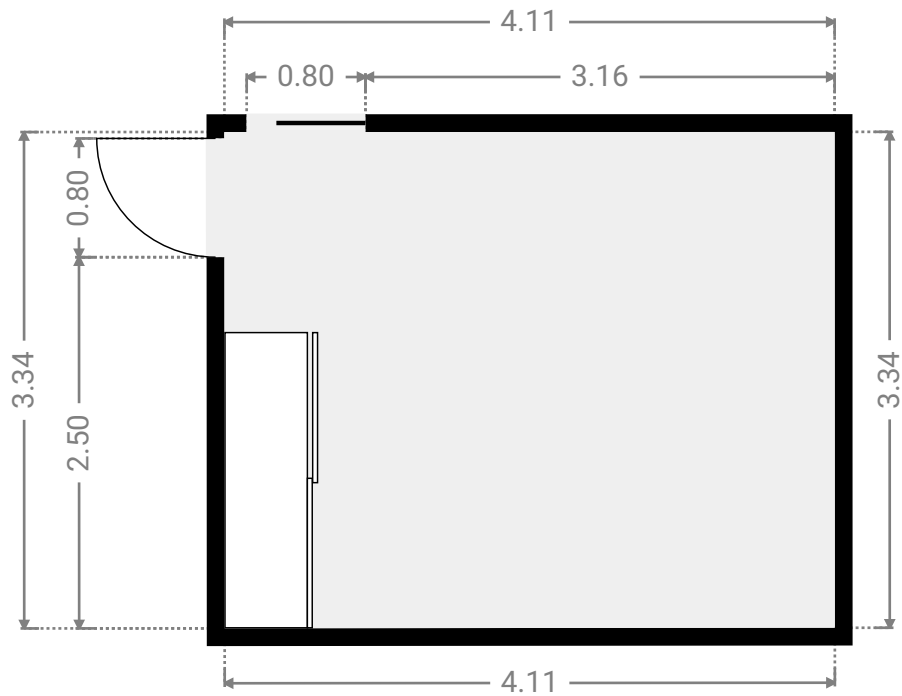

▼ **Hall**
1st Floor

WIDTH: 2.11 m • LENGTH: 4.00 m
AREA: 4.51 m² • PERIMETER: 12.21 m

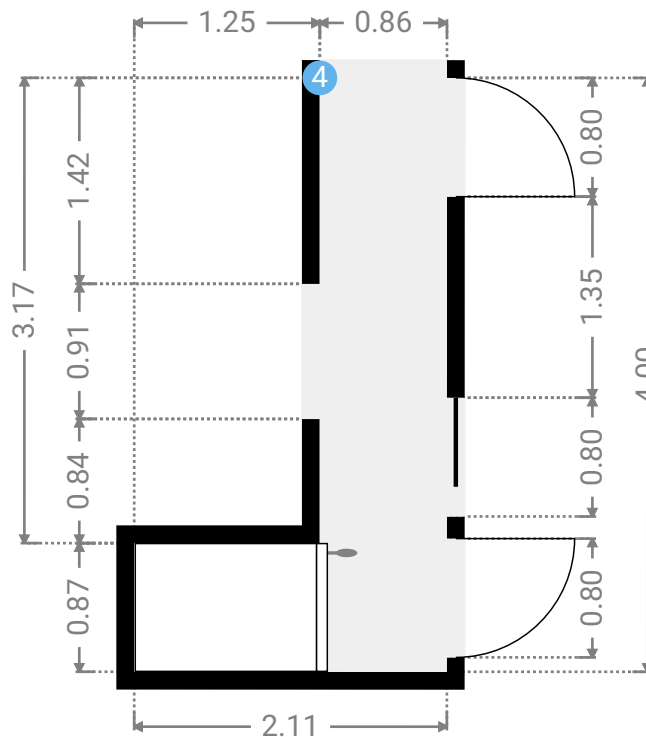
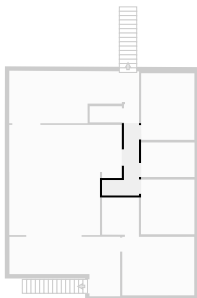

▼ **Hall**
1st Floor

WIDTH: 0.86 m • LENGTH: 1.11 m
AREA: 0.95 m² • PERIMETER: 3.94 m

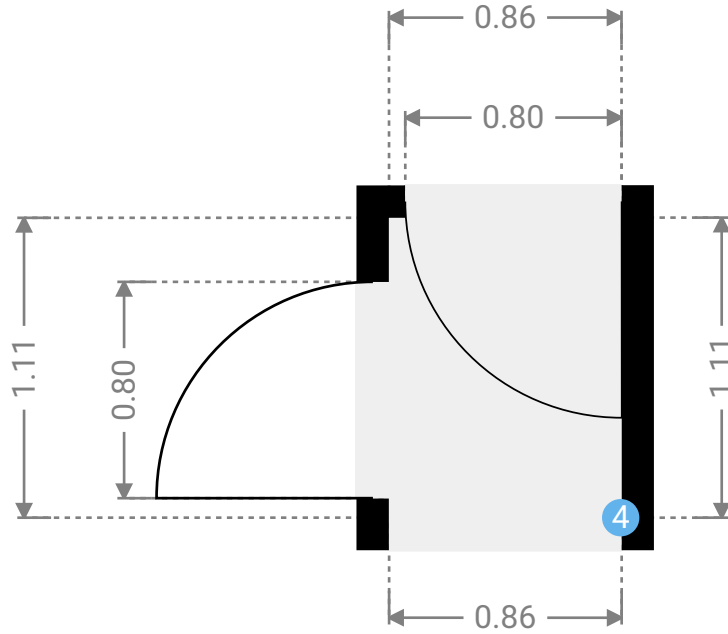

▼ **Hall/1st Floor**

4 OPENING

Height
0.00 m



▼ Kitchen
1st Floor

WIDTH: 6.43 m • LENGTH: 3.04 m
AREA: 17.05 m² • PERIMETER: 18.94 m

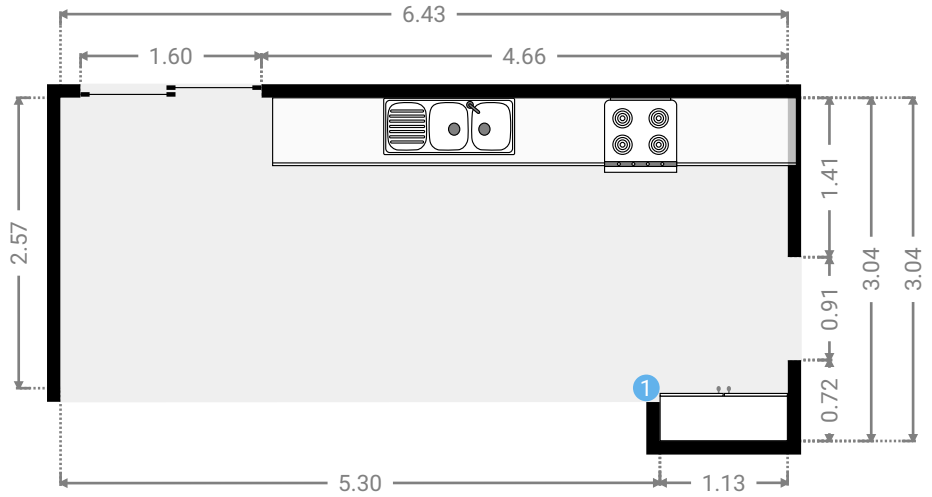
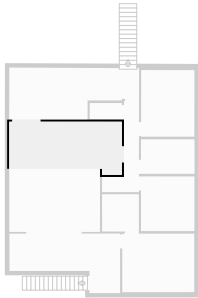

▼ Living Room
1st Floor

WIDTH: 6.32 m • LENGTH: 3.40 m
AREA: 15.69 m² • PERIMETER: 19.44 m

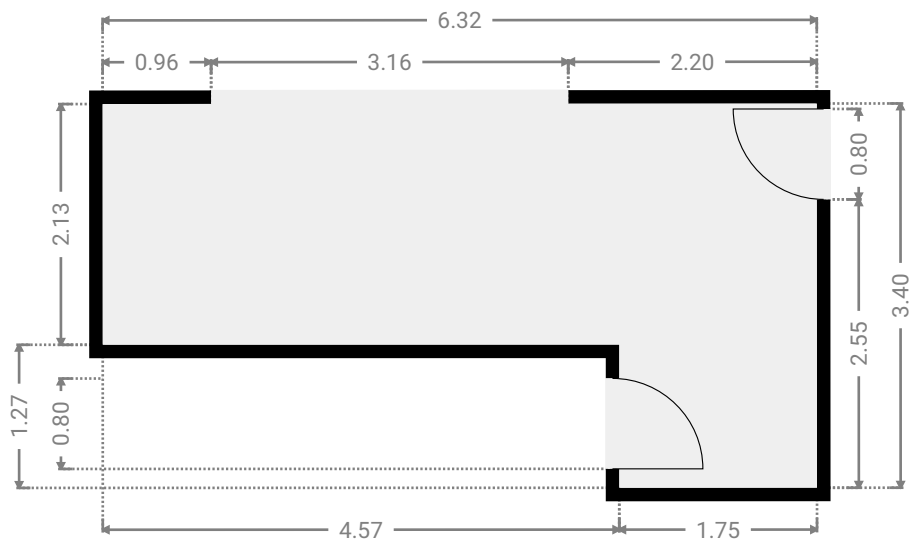

▼ Living Room
1st Floor

WIDTH: 5.18 m • LENGTH: 3.63 m
AREA: 18.79 m² • PERIMETER: 17.62 m

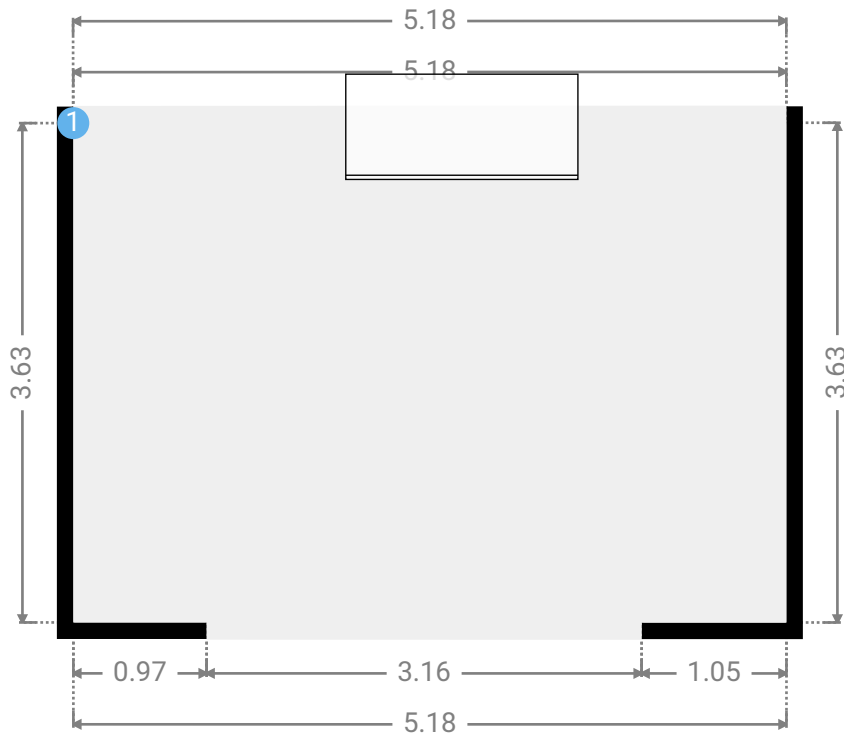
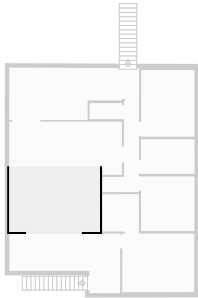

▼ Living Room/1st Floor

1 OPENING

Height
0.00 m



▼ **Other**
1st Floor

WIDTH: 7.42 m • LENGTH: 3.00 m
AREA: 18.71 m² • PERIMETER: 20.79 m

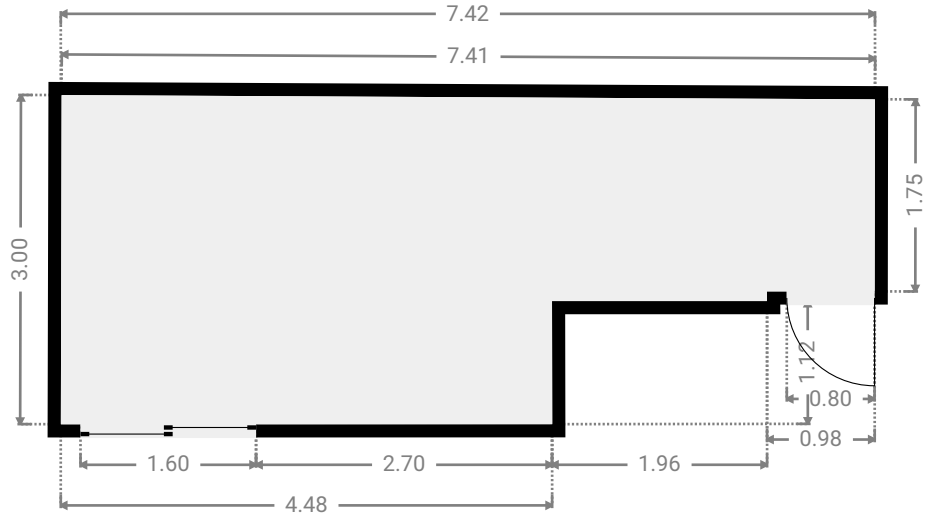

▼ **Toilet**
1st Floor

WIDTH: 1.84 m • LENGTH: 0.92 m
AREA: 1.69 m² • PERIMETER: 5.52 m

