

142 Caporn Road

Created on
2021-03-25

Floors
1

▼ Ground Floor

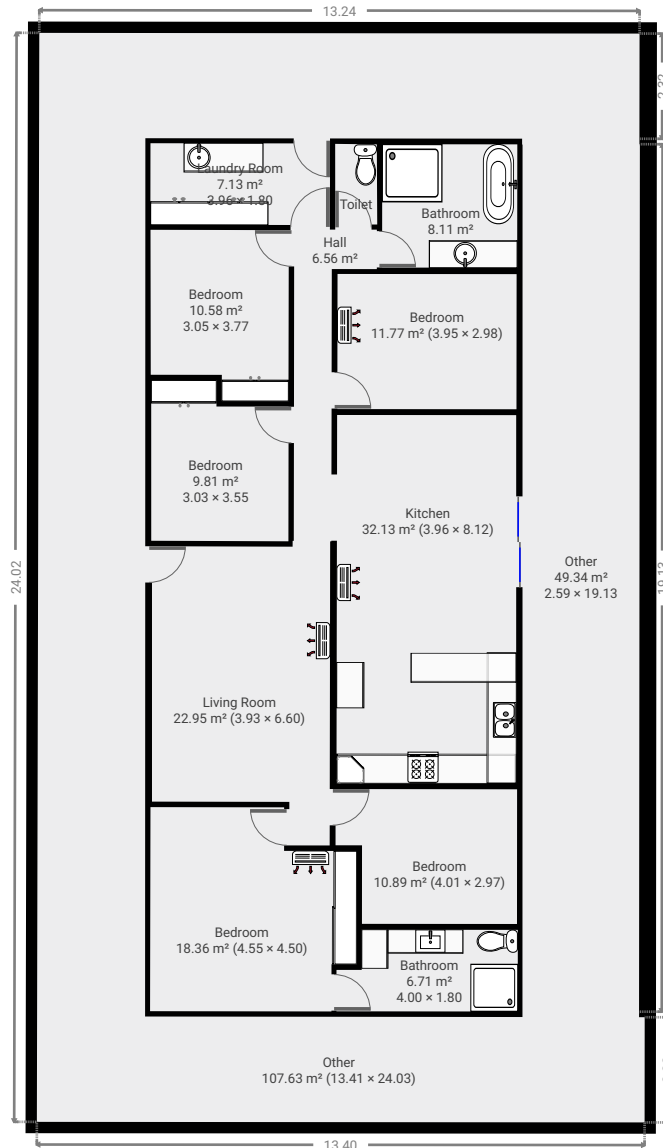
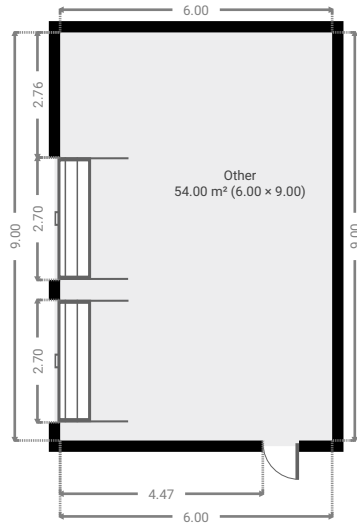

▼ Living Room
Ground Floor

WIDTH: 6.60 m • LENGTH: 3.93 m
AREA: 22.95 m² • PERIMETER: 21.03 m

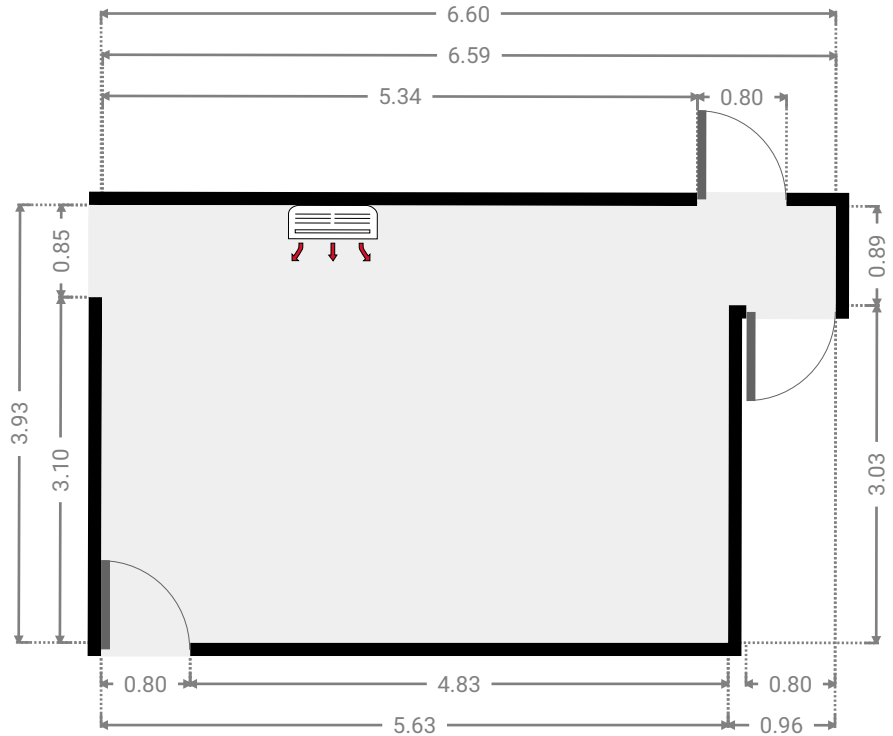
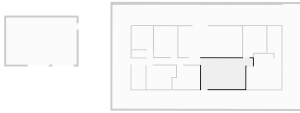

▼ Bedroom
Ground Floor

WIDTH: 4.50 m • LENGTH: 4.55 m
AREA: 18.36 m² • PERIMETER: 18.10 m

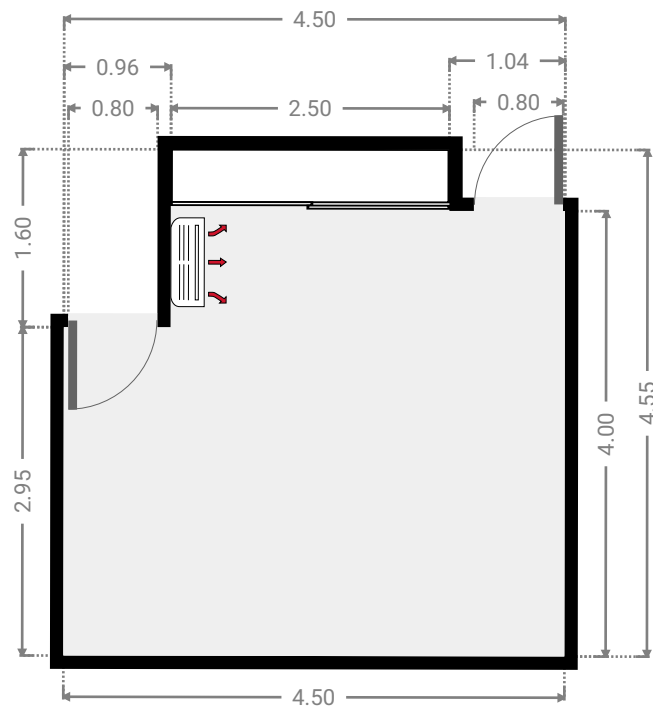
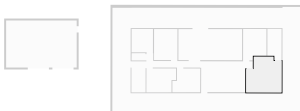

▼ **Bathroom**
Ground Floor

WIDTH: 1.80 m • LENGTH: 4.00 m
AREA: 6.71 m² • PERIMETER: 11.60 m

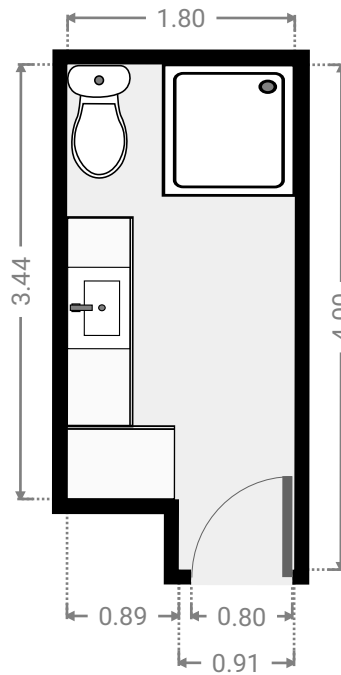
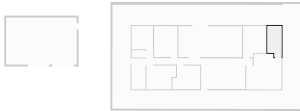

▼ **Bedroom**
Ground Floor

WIDTH: 2.97 m • LENGTH: 4.01 m
AREA: 10.89 m² • PERIMETER: 13.95 m

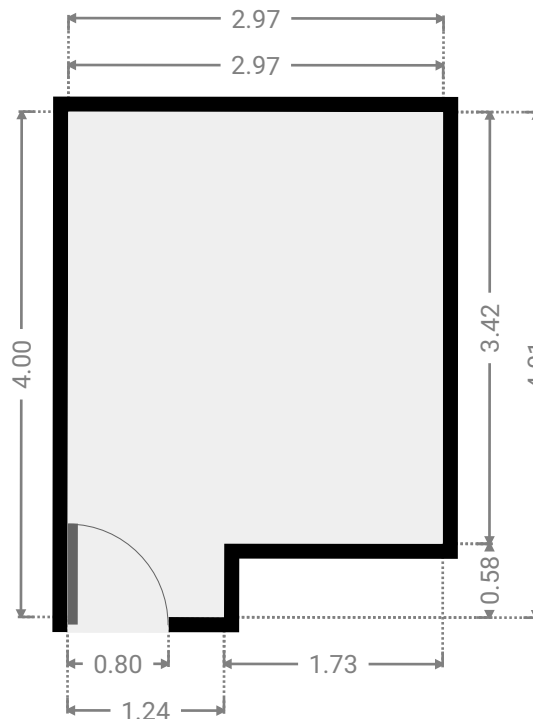
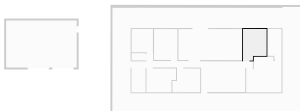

▼ Kitchen
Ground Floor

WIDTH: 8.12 m • LENGTH: 3.96 m
AREA: 32.13 m² • PERIMETER: 24.15 m

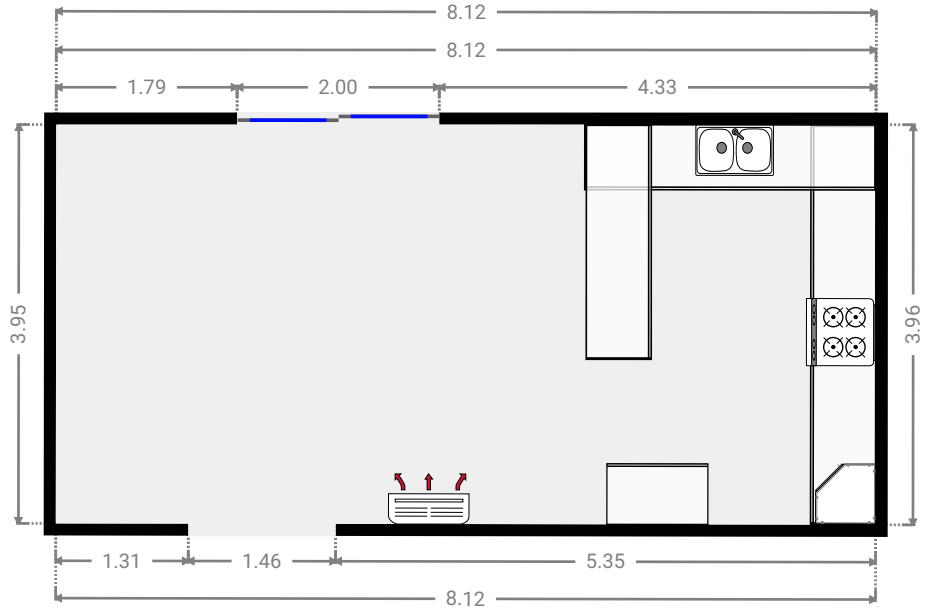

▼ Hall
Ground Floor

WIDTH: 6.88 m • LENGTH: 1.82 m
AREA: 6.56 m² • PERIMETER: 17.39 m

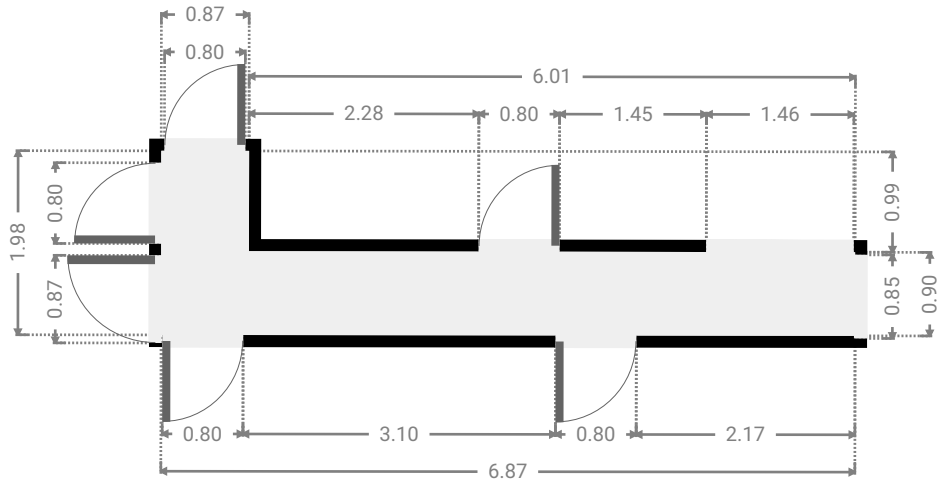
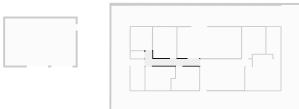

▼ **Bedroom**
Ground Floor

WIDTH: 3.55 m • LENGTH: 3.03 m
AREA: 9.81 m² • PERIMETER: 13.15 m

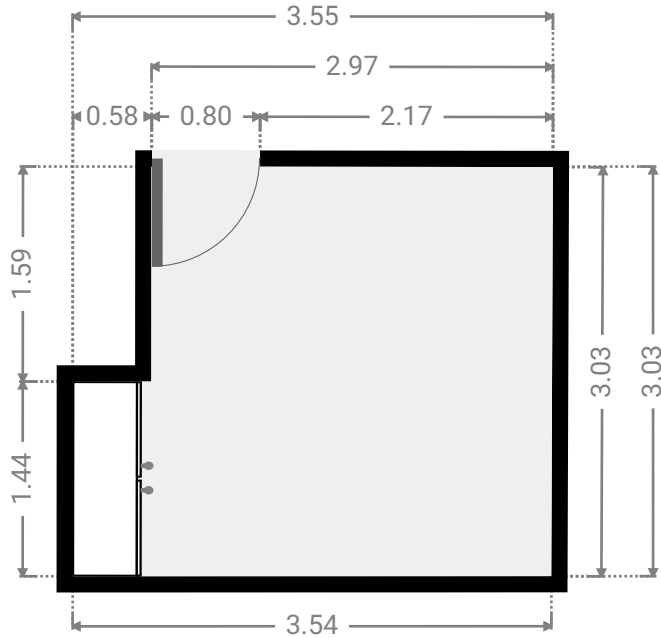
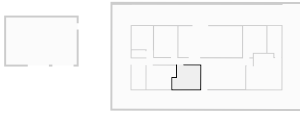

▼ **Bedroom**
Ground Floor

WIDTH: 2.98 m • LENGTH: 3.95 m
AREA: 11.77 m² • PERIMETER: 13.86 m

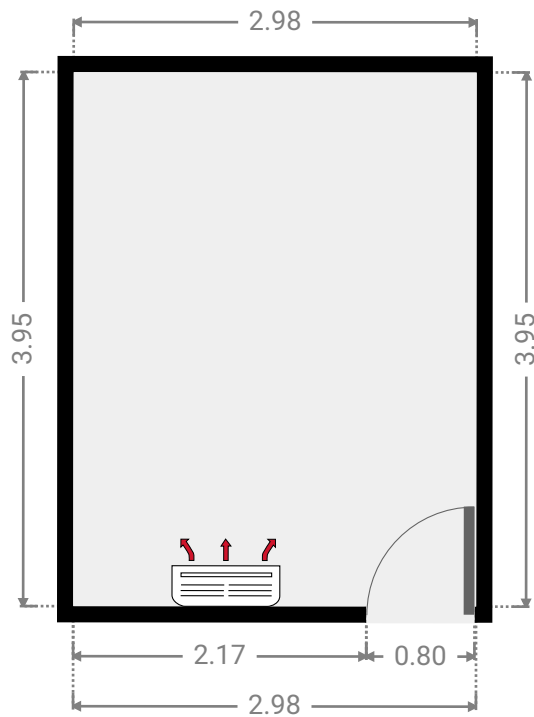
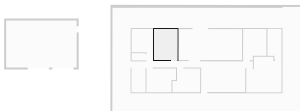

▼ **Bedroom**
Ground Floor

WIDTH: 3.77 m • LENGTH: 3.05 m
AREA: 10.58 m² • PERIMETER: 13.64 m

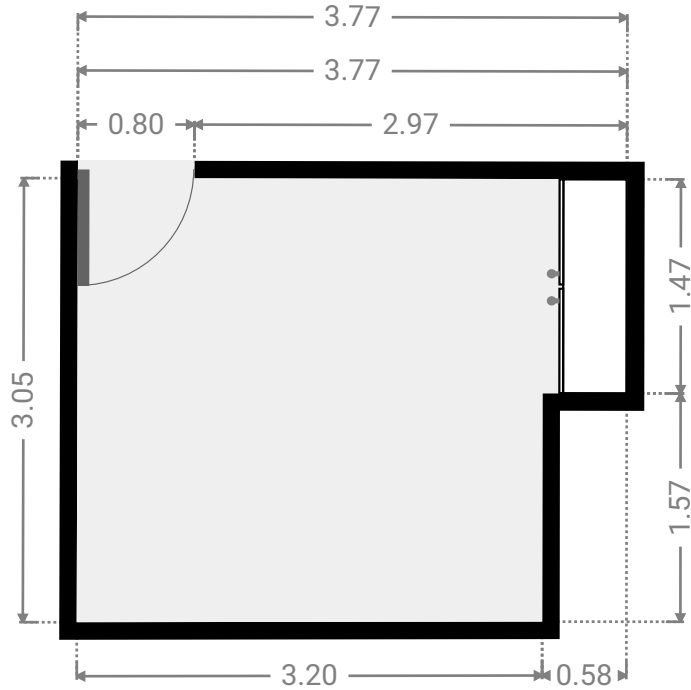
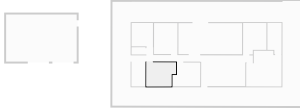

▼ **Laundry Room**
Ground Floor

WIDTH: 1.80 m • LENGTH: 3.96 m
AREA: 7.13 m² • PERIMETER: 11.52 m

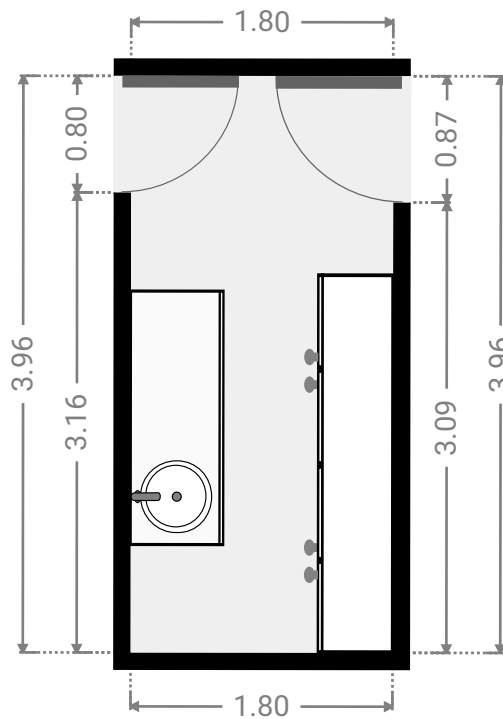
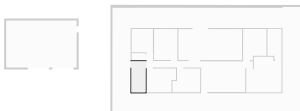

▼ Bathroom
Ground Floor

WIDTH: 2.72 m • LENGTH: 2.98 m
AREA: 8.11 m² • PERIMETER: 11.40 m

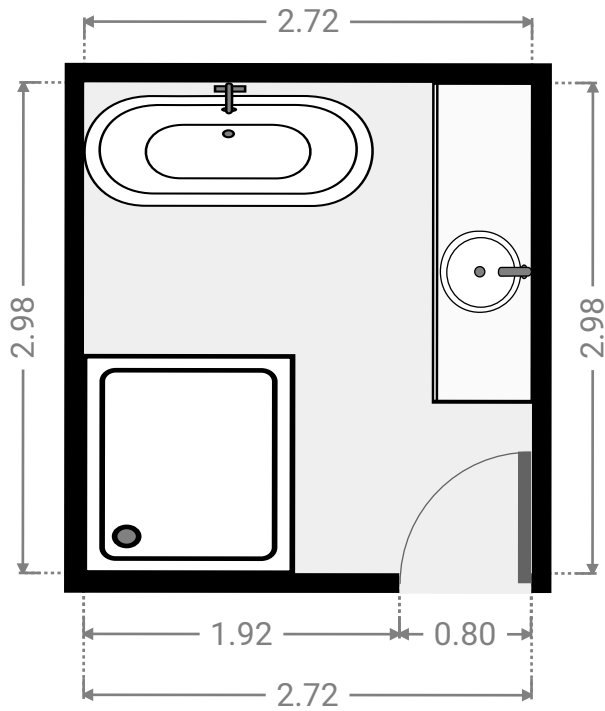
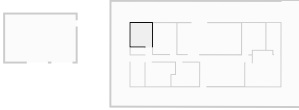

▼ Toilet
Ground Floor

WIDTH: 1.78 m • LENGTH: 0.93 m
AREA: 1.64 m² • PERIMETER: 5.39 m

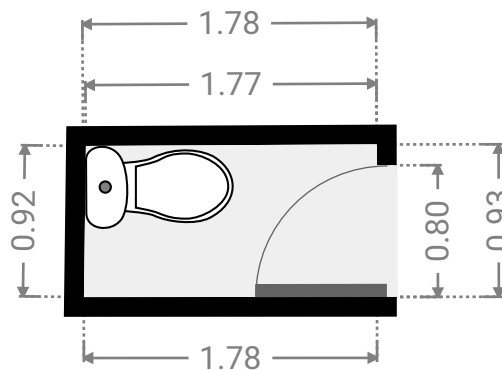

▼ Other
Ground Floor

WIDTH: 24.03 m • LENGTH: 13.41 m
AREA: 107.63 m² • PERIMETER: 96.59 m

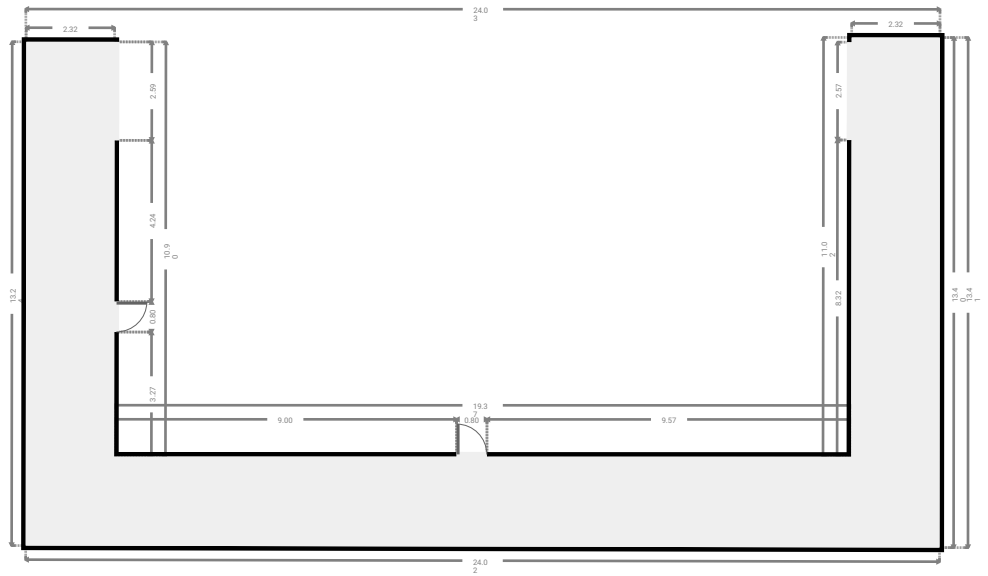
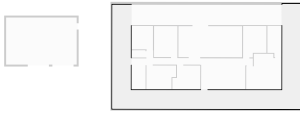

▼ Other
Ground Floor

WIDTH: 19.13 m • LENGTH: 2.59 m
AREA: 49.34 m² • PERIMETER: 43.42 m

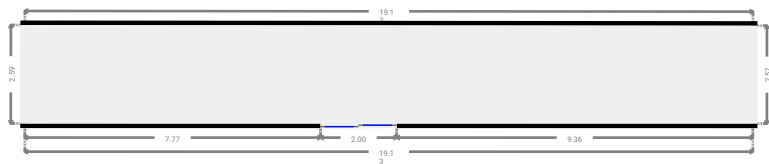
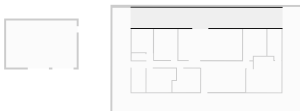

▼ Other
Ground Floor

WIDTH: 9.00 m • LENGTH: 6.00 m
AREA: 54.00 m² • PERIMETER: 30.00 m

