

140-142 Codd Street

Created on
2021-08-09

Floors
2

▼ Ground Floor

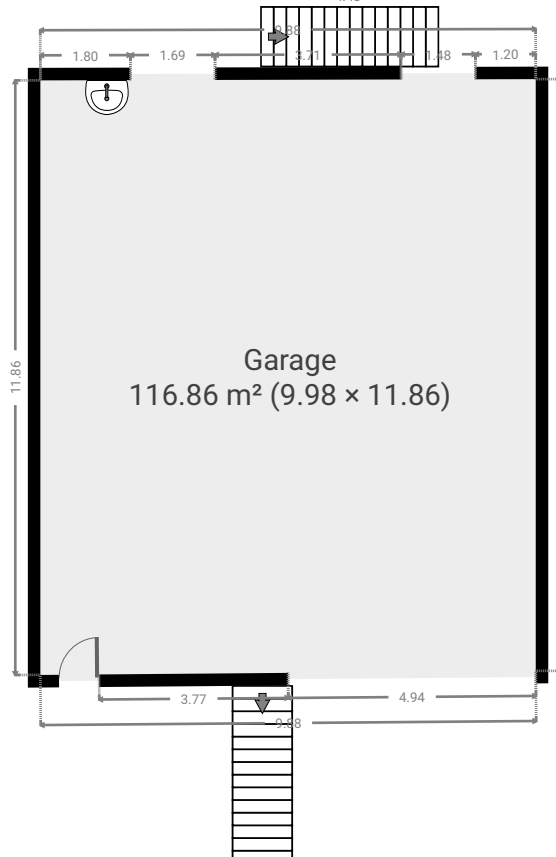
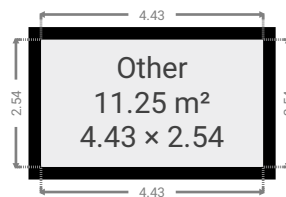
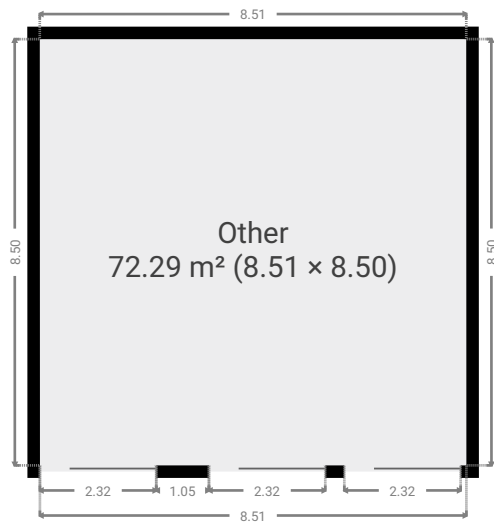

▼ **Garage**
Ground Floor

WIDTH: 9.98 m • LENGTH: 11.86 m
AREA: 116.86 m² • PERIMETER: 43.42 m

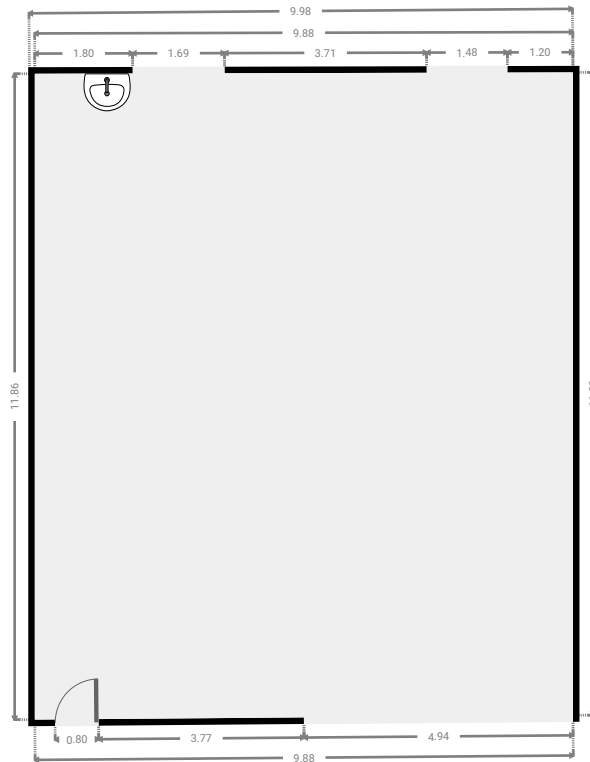
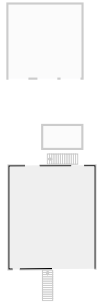

▼ **Other**
Ground Floor

WIDTH: 4.43 m • LENGTH: 2.54 m
AREA: 11.25 m² • PERIMETER: 13.94 m

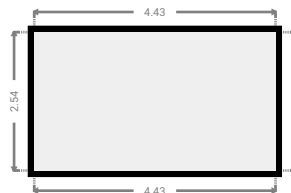
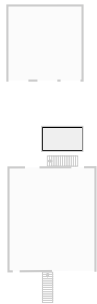

▼ Other
Ground Floor

WIDTH: 8.51 m • LENGTH: 8.50 m
AREA: 72.29 m² • PERIMETER: 34.01 m

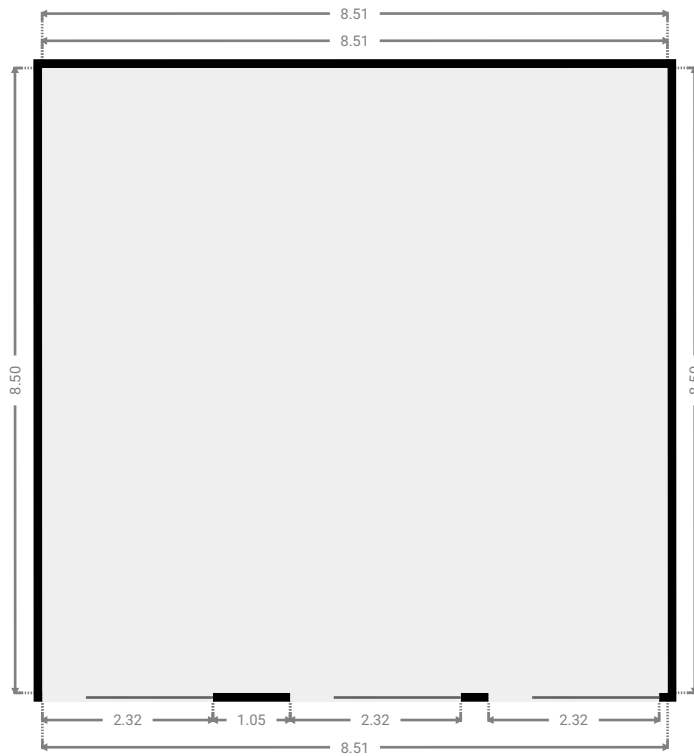

▼ 1st Floor

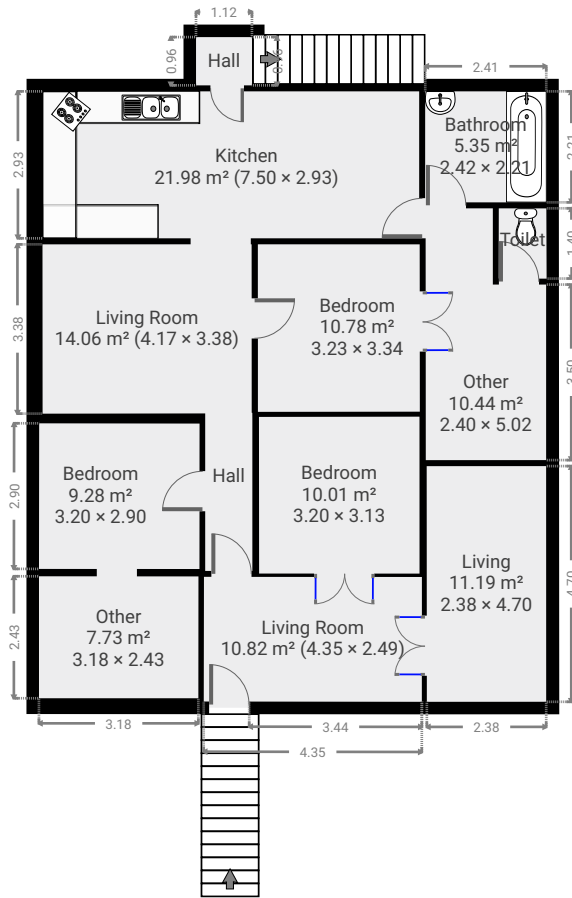

▼ Living Room
1st Floor

WIDTH: 4.35 m • LENGTH: 2.49 m
AREA: 10.82 m² • PERIMETER: 13.67 m

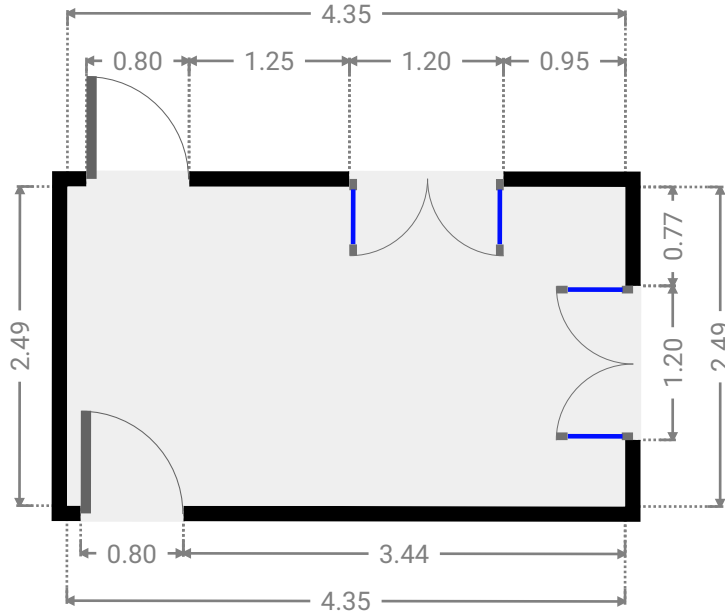
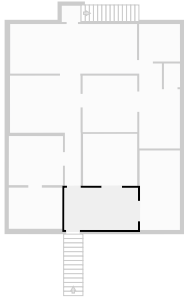

▼ Living
1st Floor

WIDTH: 2.38 m • LENGTH: 4.70 m
AREA: 11.19 m² • PERIMETER: 14.16 m

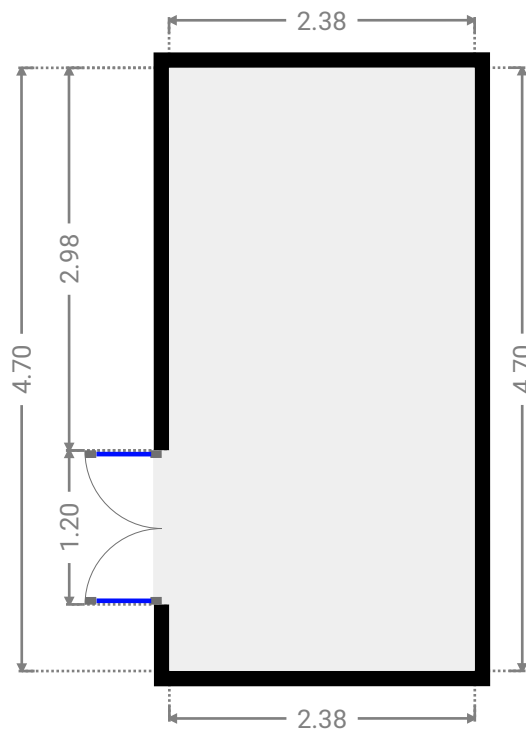
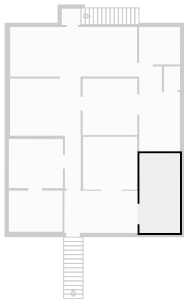

▼ **Bedroom**
1st Floor

WIDTH: 3.20 m • LENGTH: 3.13 m
AREA: 10.01 m² • PERIMETER: 12.66 m

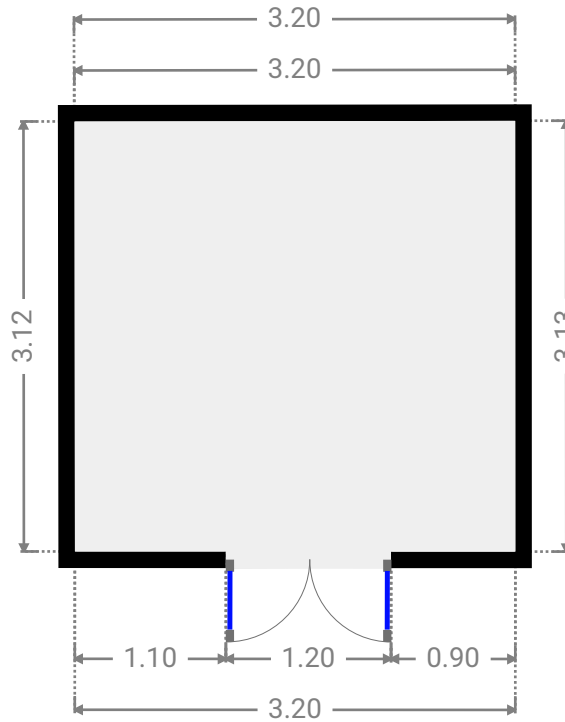
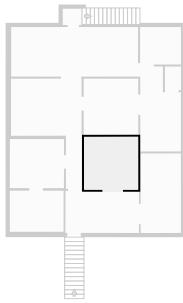

▼ **Hall**
1st Floor

WIDTH: 0.94 m • LENGTH: 3.02 m
AREA: 2.84 m² • PERIMETER: 7.92 m

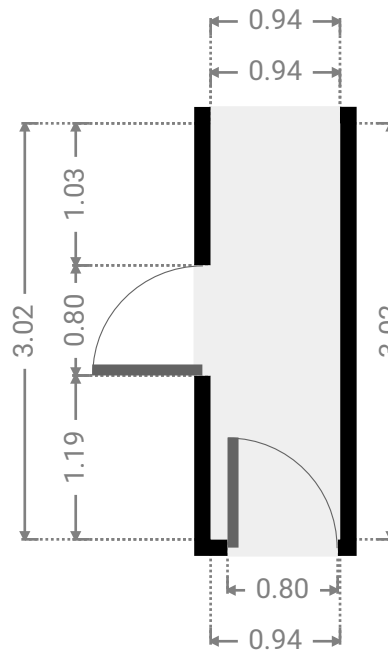
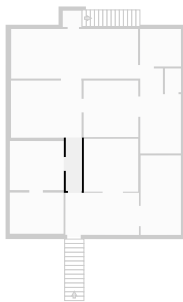

▼ Other
1st Floor

WIDTH: 3.18 m • LENGTH: 2.43 m
AREA: 7.73 m² • PERIMETER: 11.22 m

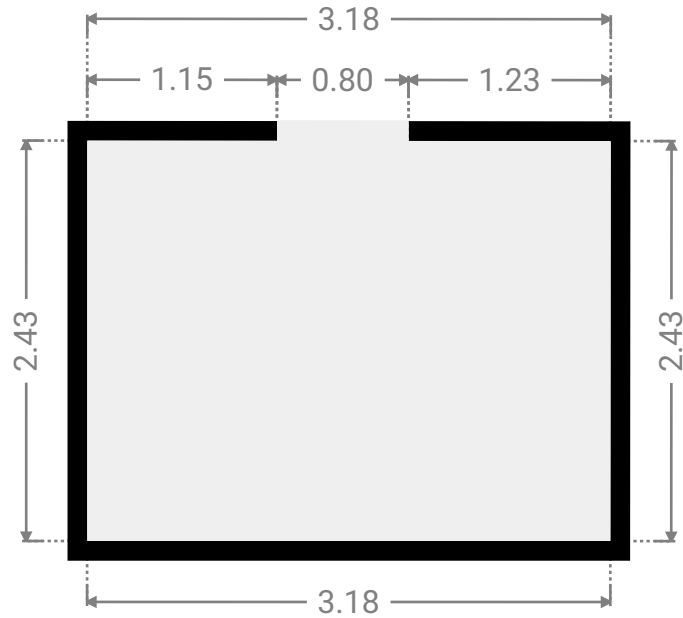
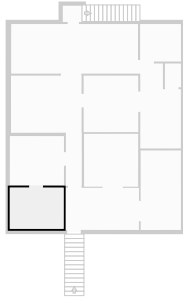

▼ Bedroom
1st Floor

WIDTH: 3.20 m • LENGTH: 2.90 m
AREA: 9.28 m² • PERIMETER: 12.20 m

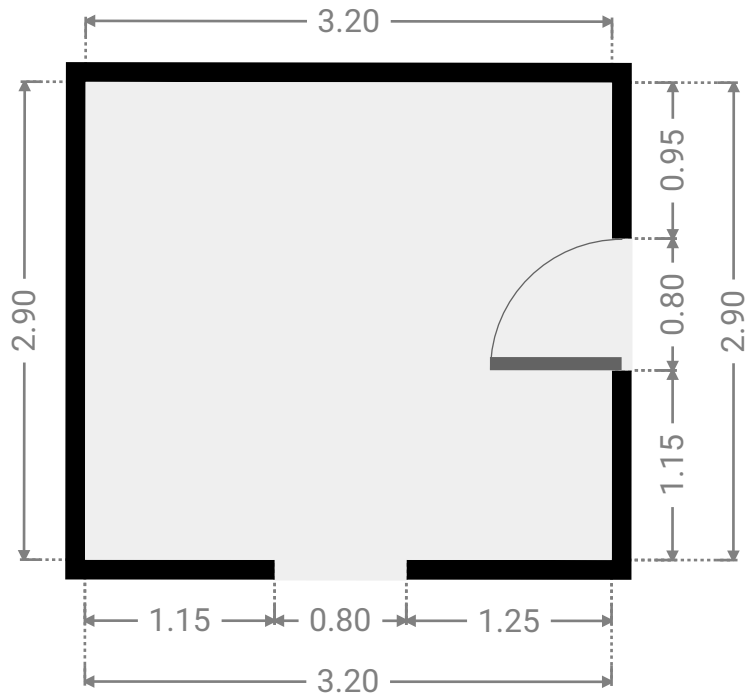
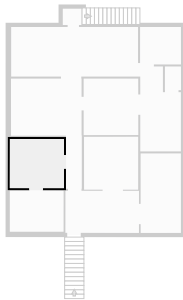

▼ Living Room
1st Floor

WIDTH: 4.17 m • LENGTH: 3.38 m
AREA: 14.06 m² • PERIMETER: 15.09 m

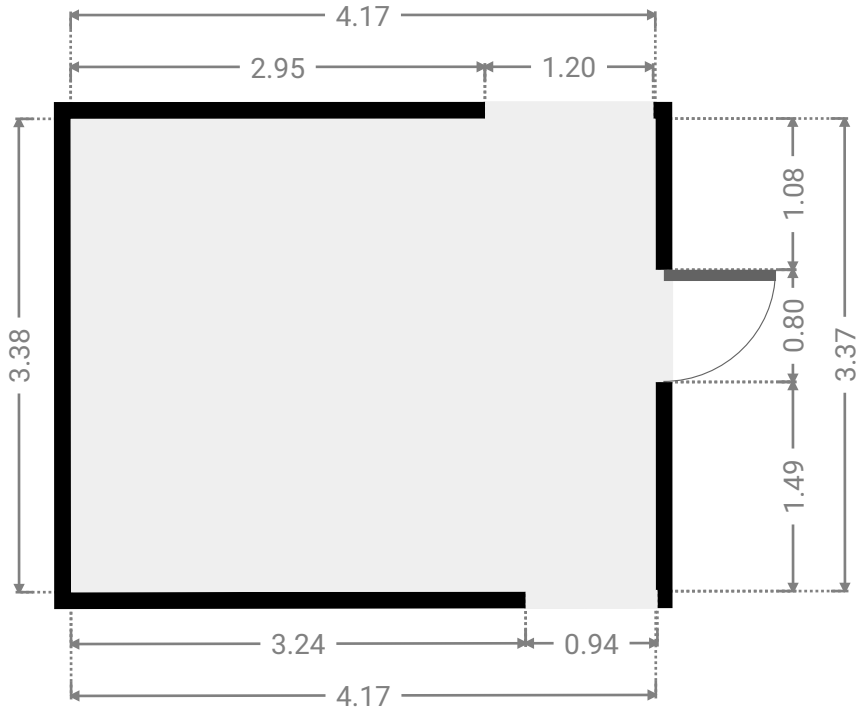
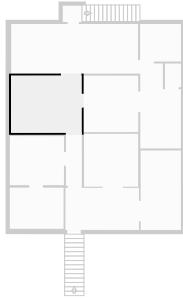

▼ Bedroom
1st Floor

WIDTH: 3.23 m • LENGTH: 3.34 m
AREA: 10.78 m² • PERIMETER: 13.13 m

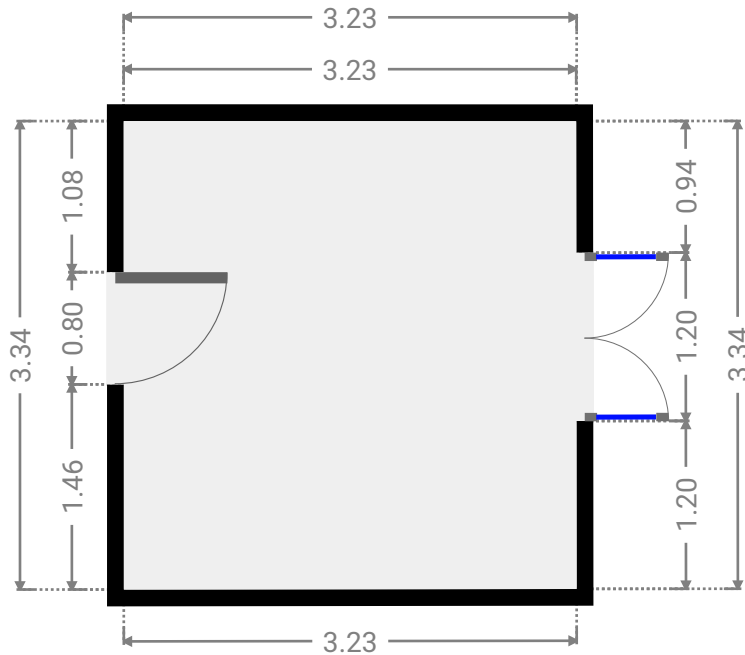
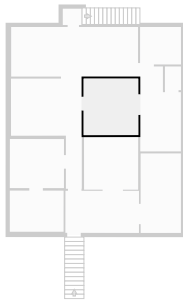

▼ Kitchen
1st Floor

WIDTH: 7.50 m • LENGTH: 2.93 m
AREA: 21.98 m² • PERIMETER: 20.87 m

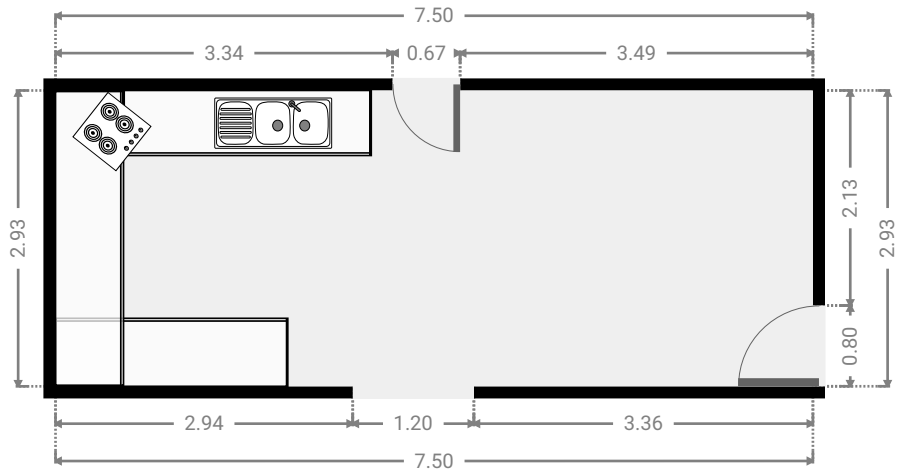
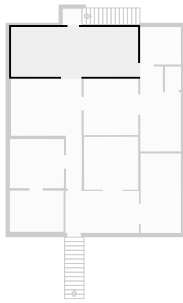

▼ Other
1st Floor

WIDTH: 2.40 m • LENGTH: 5.02 m
AREA: 10.44 m² • PERIMETER: 14.84 m

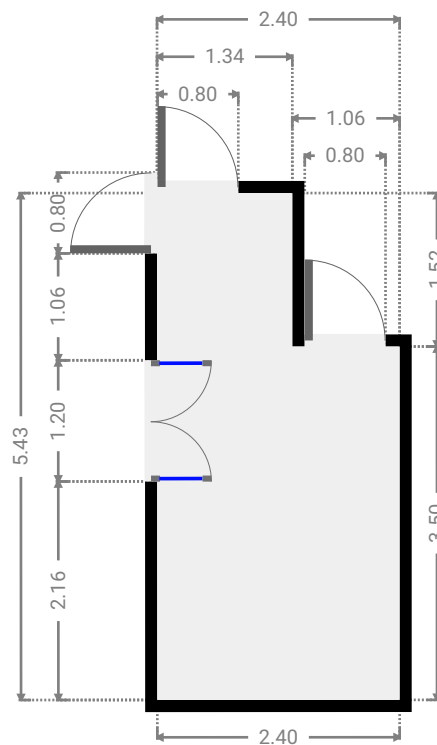
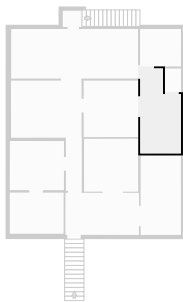

▼ **Toilet**
1st Floor

WIDTH: 0.96 m • LENGTH: 1.40 m
AREA: 1.33 m² • PERIMETER: 4.70 m

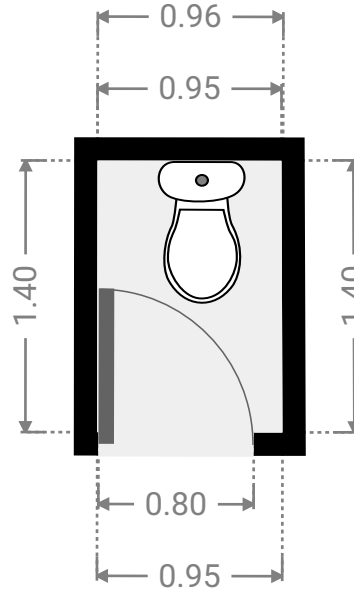

▼ **Bathroom**
1st Floor

WIDTH: 2.42 m • LENGTH: 2.21 m
AREA: 5.35 m² • PERIMETER: 9.26 m

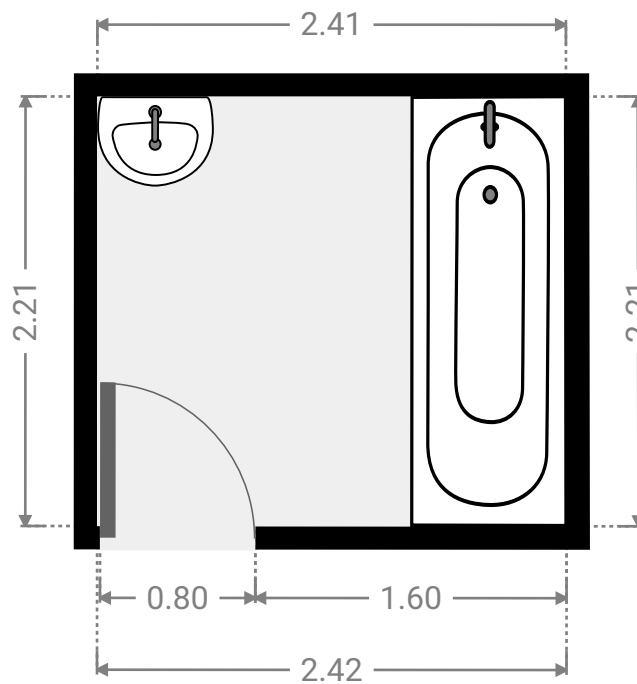
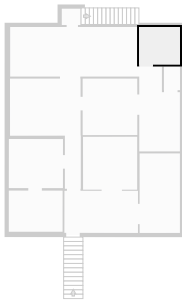

▼ **Hall**
1st Floor

WIDTH: 1.12 m • LENGTH: 0.96 m
AREA: 1.07 m² • PERIMETER: 4.16 m

