

# 140 Talbot Street

**SUBMITTED BY**

Ray White Rockhampton Casey  
stockers@cqoz.com

---

**CREATED ON**

2022-08-10

---

**Floors**

2

---

▼ Ground Floor

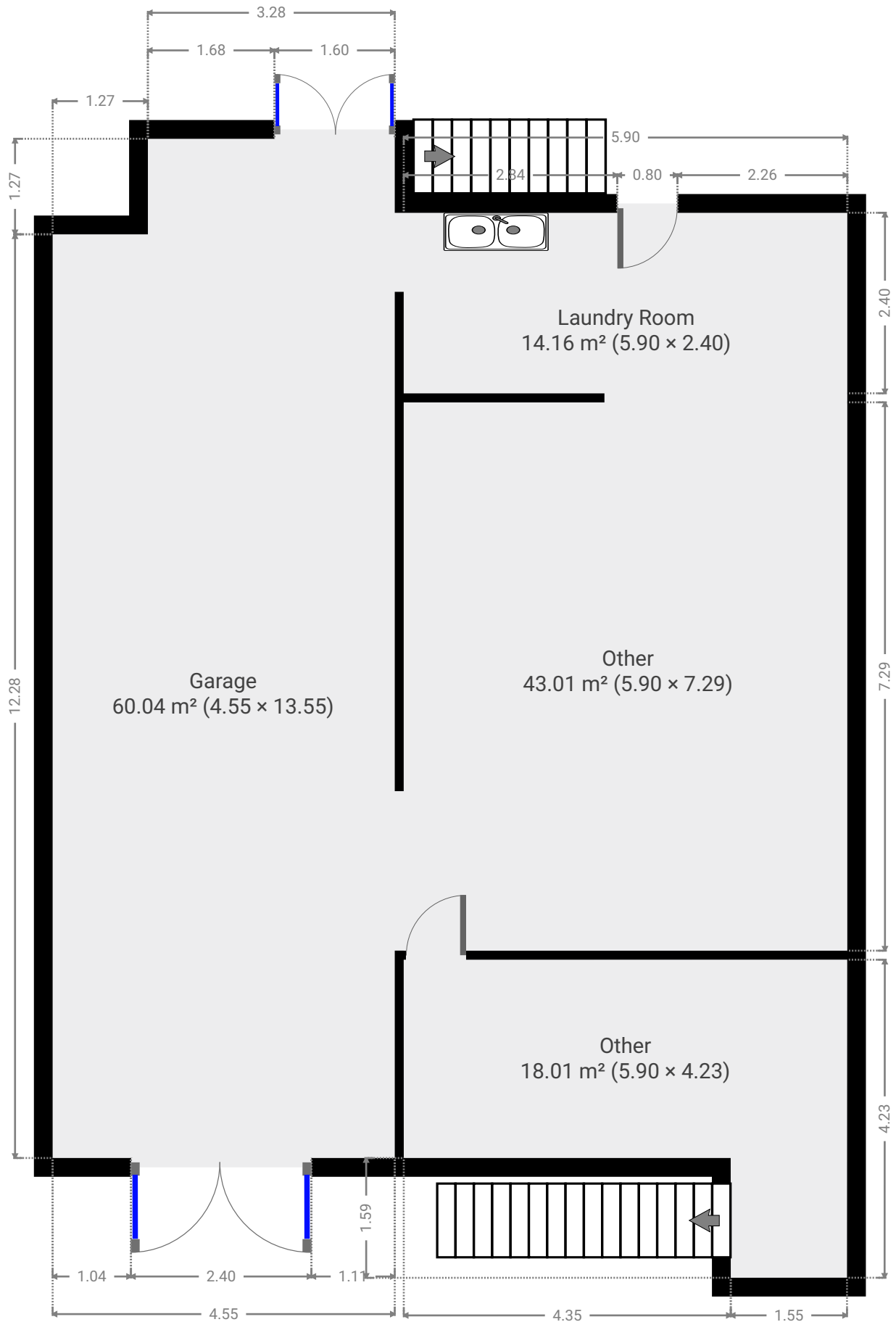

▼ **Garage**  
Ground Floor

WIDTH: 4.55 m • LENGTH: 13.55 m  
AREA: 60.04 m<sup>2</sup> • PERIMETER: 36.20 m

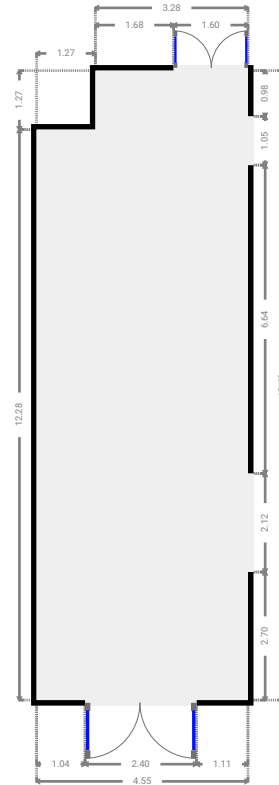
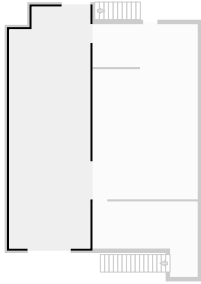

▼ **Laundry Room**  
Ground Floor

WIDTH: 5.90 m • LENGTH: 2.40 m  
AREA: 14.16 m<sup>2</sup> • PERIMETER: 16.60 m

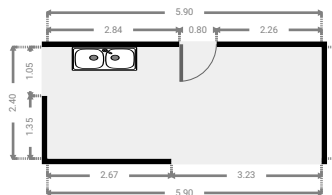
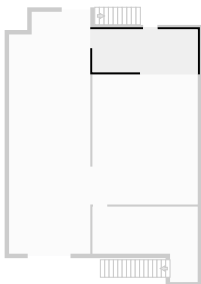

▼ Other  
Ground Floor

WIDTH: 5.90 m • LENGTH: 7.29 m  
AREA: 43.01 m<sup>2</sup> • PERIMETER: 26.38 m

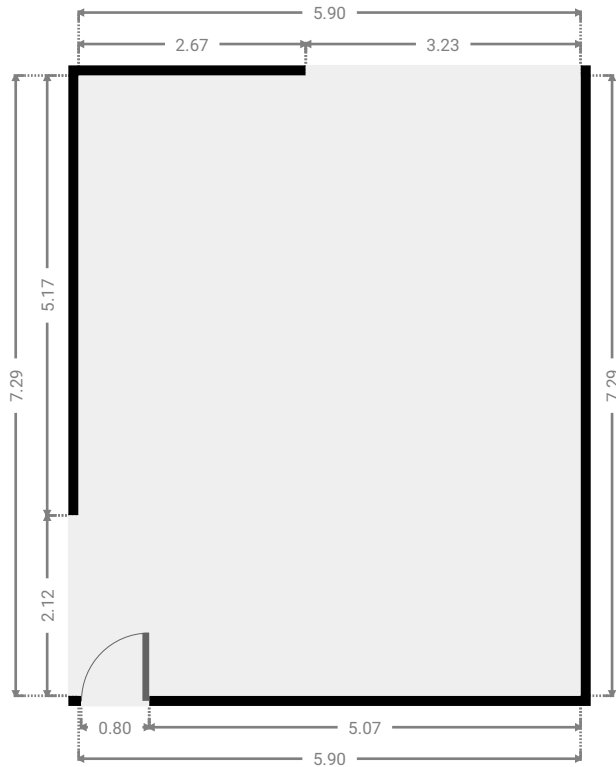
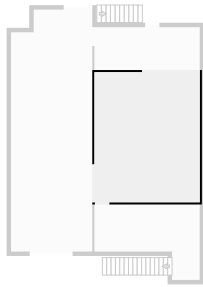

▼ Other  
Ground Floor

WIDTH: 5.90 m • LENGTH: 4.23 m  
AREA: 18.01 m<sup>2</sup> • PERIMETER: 20.25 m

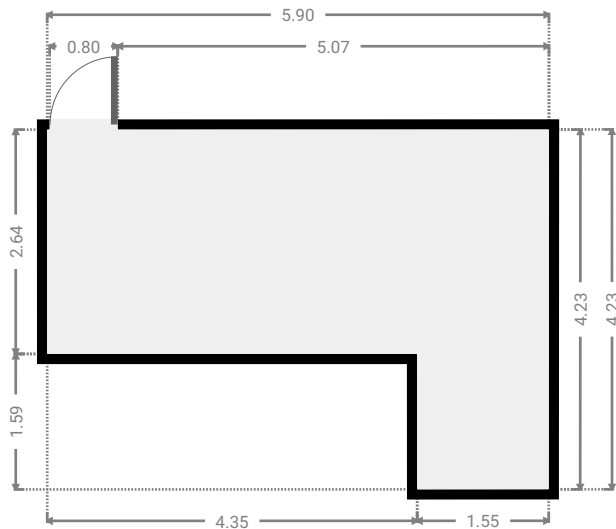
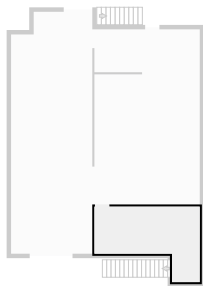

▼ 1st Floor

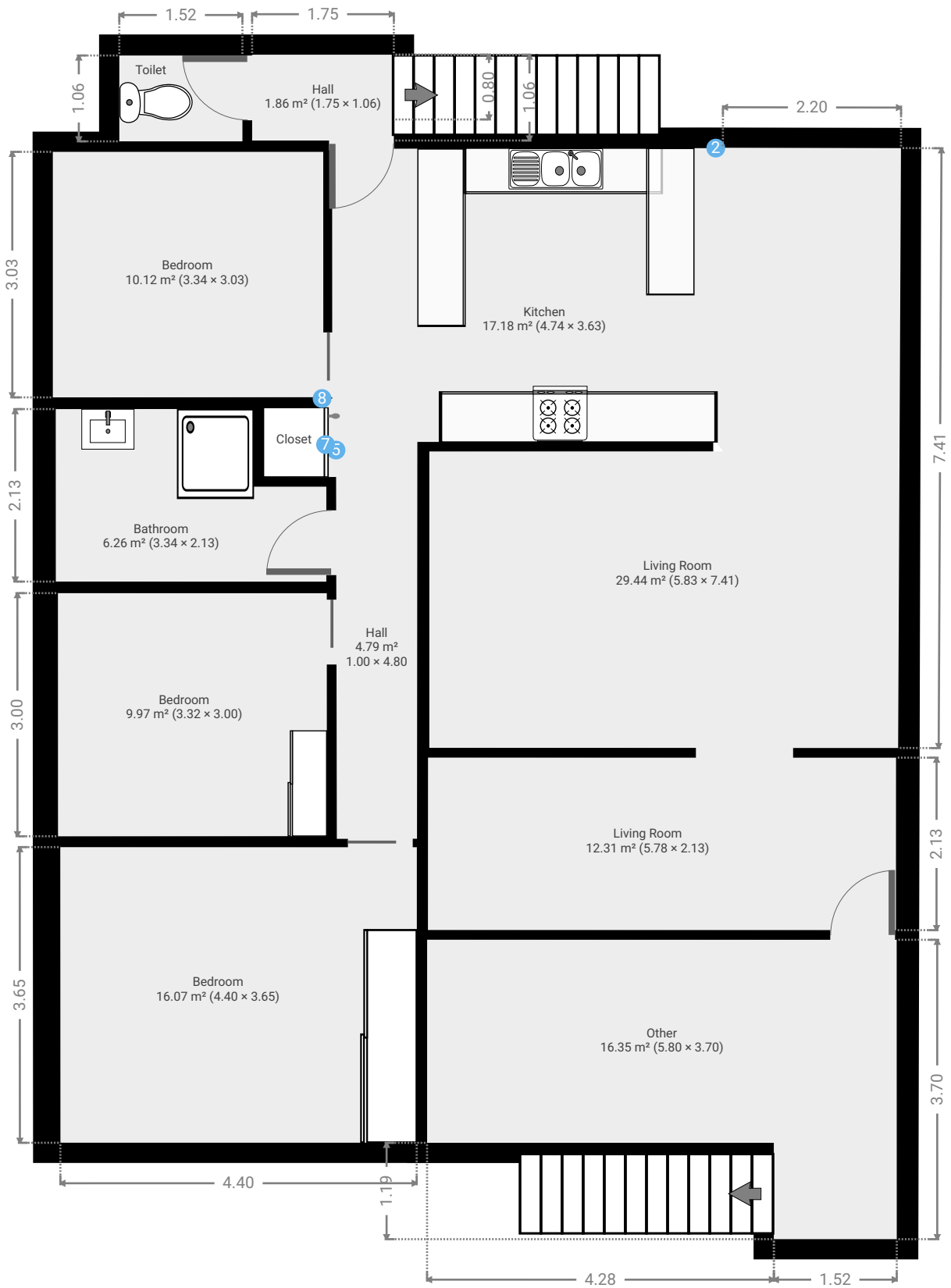

▼ Bathroom  
1st Floor

WIDTH: 3.34 m • LENGTH: 2.13 m  
AREA: 6.26 m<sup>2</sup> • PERIMETER: 10.94 m

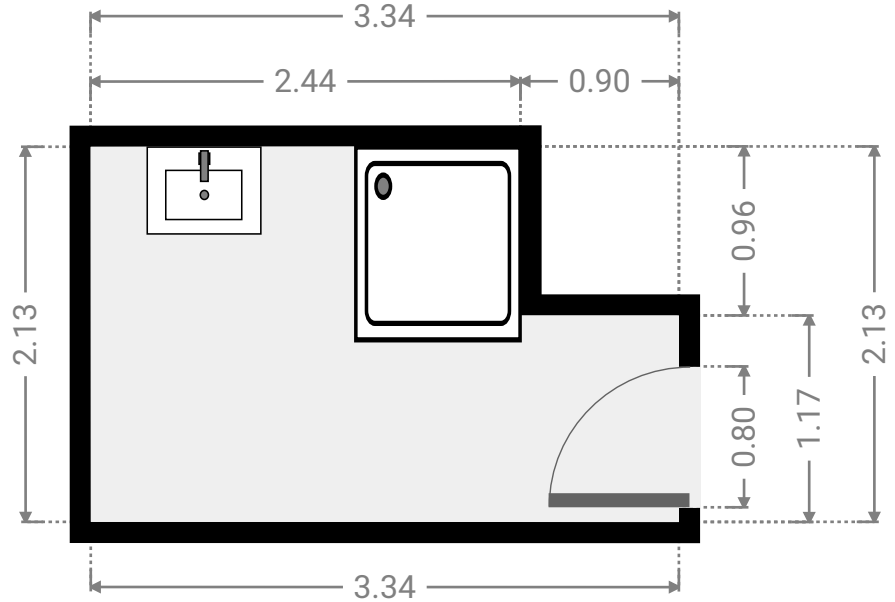
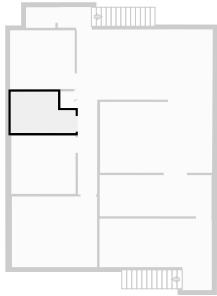

▼ Bedroom  
1st Floor

WIDTH: 3.34 m • LENGTH: 3.03 m  
AREA: 10.12 m<sup>2</sup> • PERIMETER: 12.74 m

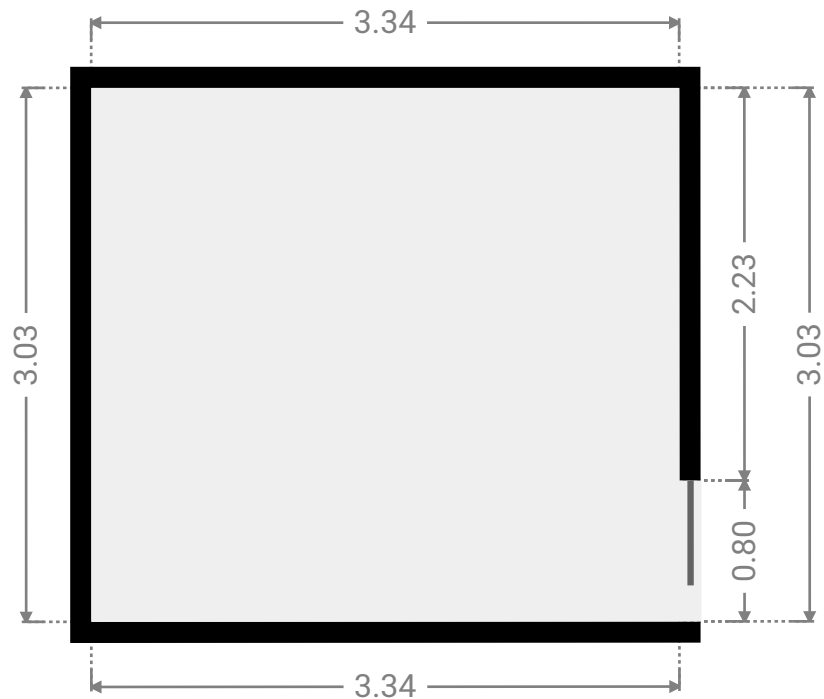
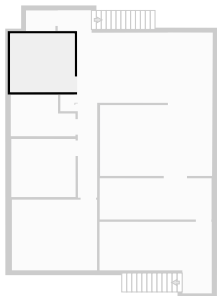

▼ **Bedroom**  
1st Floor

WIDTH: 3.32 m • LENGTH: 3.00 m  
AREA: 9.97 m<sup>2</sup> • PERIMETER: 12.64 m

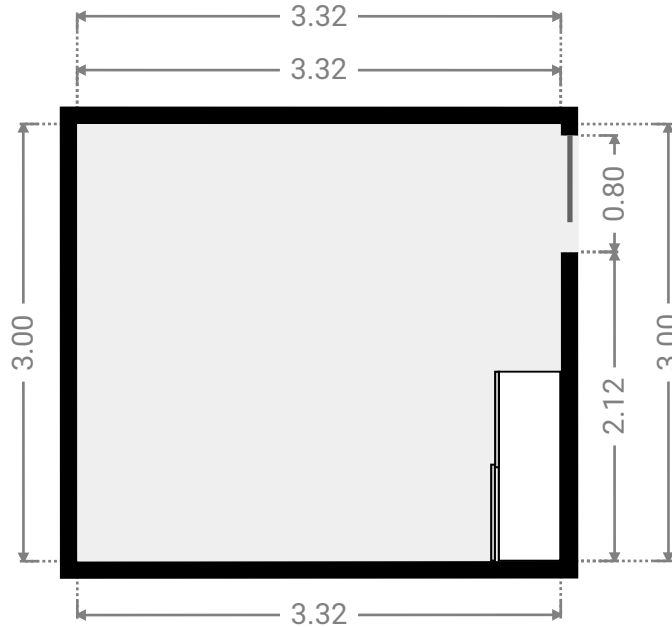
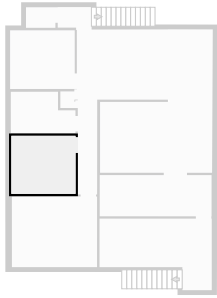

▼ **Bedroom**  
1st Floor

WIDTH: 4.40 m • LENGTH: 3.65 m  
AREA: 16.07 m<sup>2</sup> • PERIMETER: 16.10 m

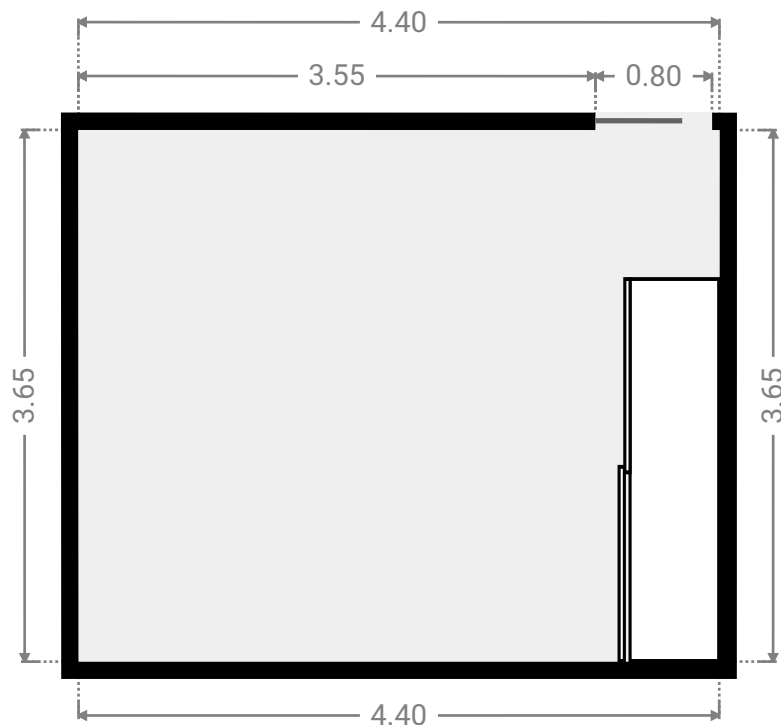
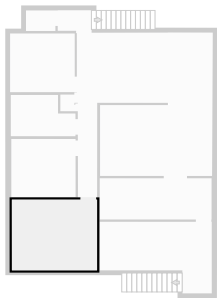

▼ **Closet**  
1st Floor

WIDTH: 0.77 m • LENGTH: 0.86 m  
AREA: 0.64 m<sup>2</sup> • PERIMETER: 3.26 m

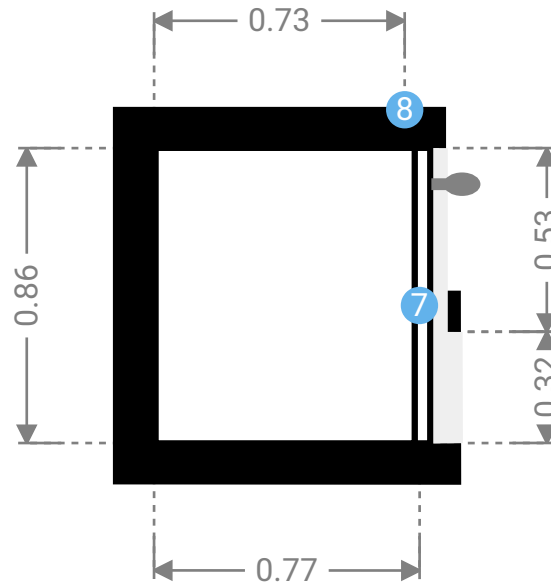
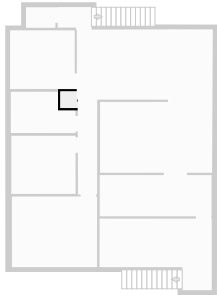

▼ **Closet/1st Floor**

**7** OPENING

Height  
0.00 m



**8** OPENING

Height  
0.00 m





▼ **Hall**  
1st Floor

WIDTH: 1.00 m • LENGTH: 4.80 m  
AREA: 4.79 m<sup>2</sup> • PERIMETER: 11.59 m

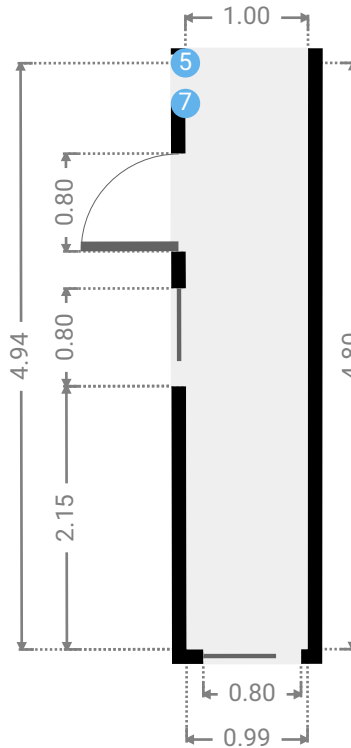
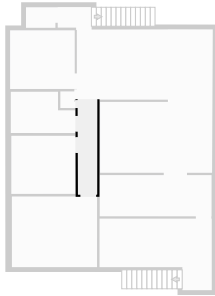

▼ **Hall/1st Floor**

**5 OPENING**

Height  
0.00 m



▼ Hall  
1st Floor

WIDTH: 1.75 m • LENGTH: 1.06 m  
AREA: 1.86 m<sup>2</sup> • PERIMETER: 5.62 m

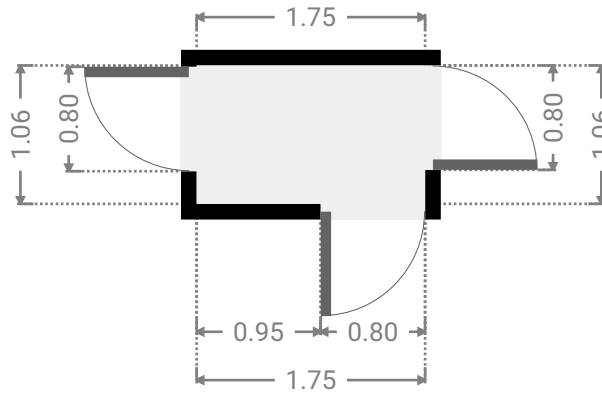
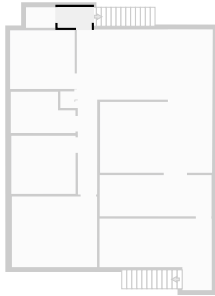

▼ Kitchen  
1st Floor

WIDTH: 4.74 m • LENGTH: 3.63 m  
AREA: 17.18 m<sup>2</sup> • PERIMETER: 16.73 m

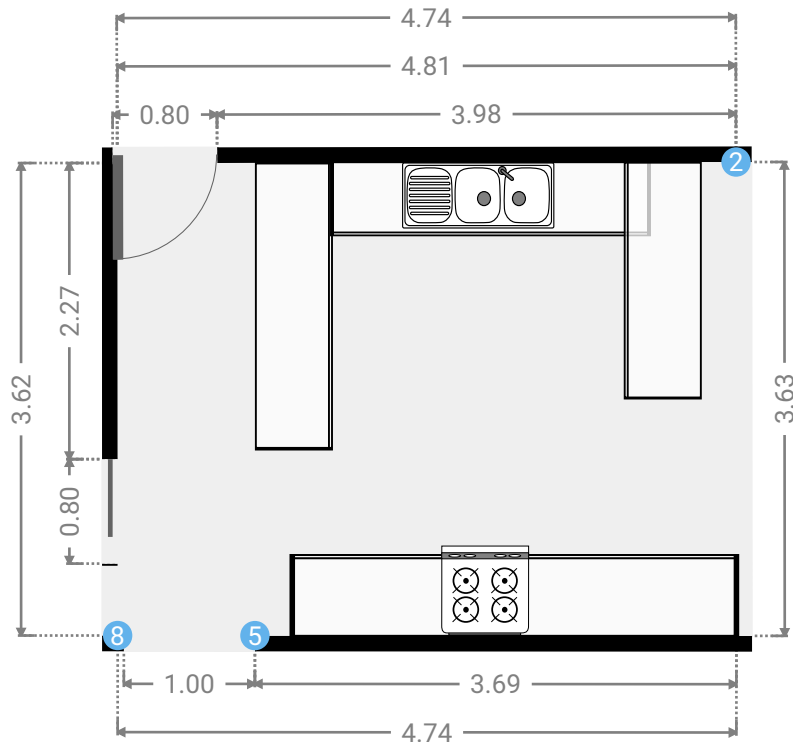
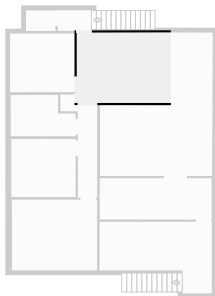

▼ Kitchen/1st Floor

2 OPENING

Height  
0.00 m



▼ Living Room  
1st Floor

WIDTH: 5.78 m • LENGTH: 2.13 m  
AREA: 12.31 m<sup>2</sup> • PERIMETER: 15.82 m

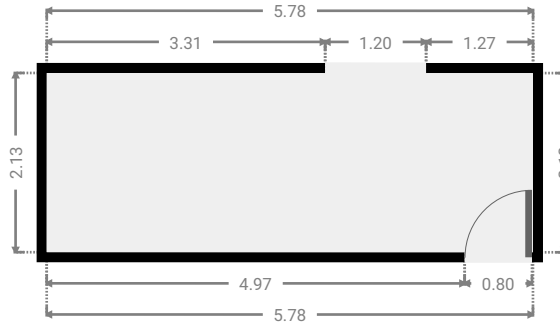
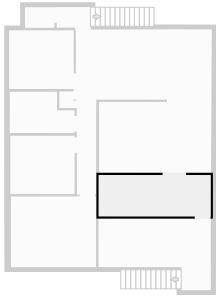

▼ Living Room  
1st Floor

WIDTH: 5.83 m • LENGTH: 7.41 m  
AREA: 29.44 m<sup>2</sup> • PERIMETER: 26.44 m

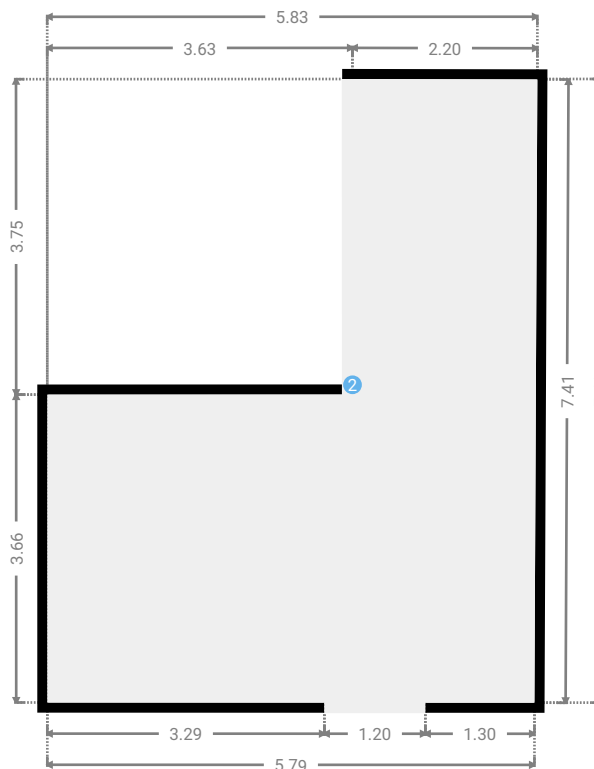
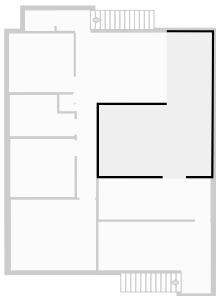

▼ **Other**  
1st Floor

WIDTH: 5.80 m • LENGTH: 3.70 m  
AREA: 16.35 m<sup>2</sup> • PERIMETER: 18.99 m

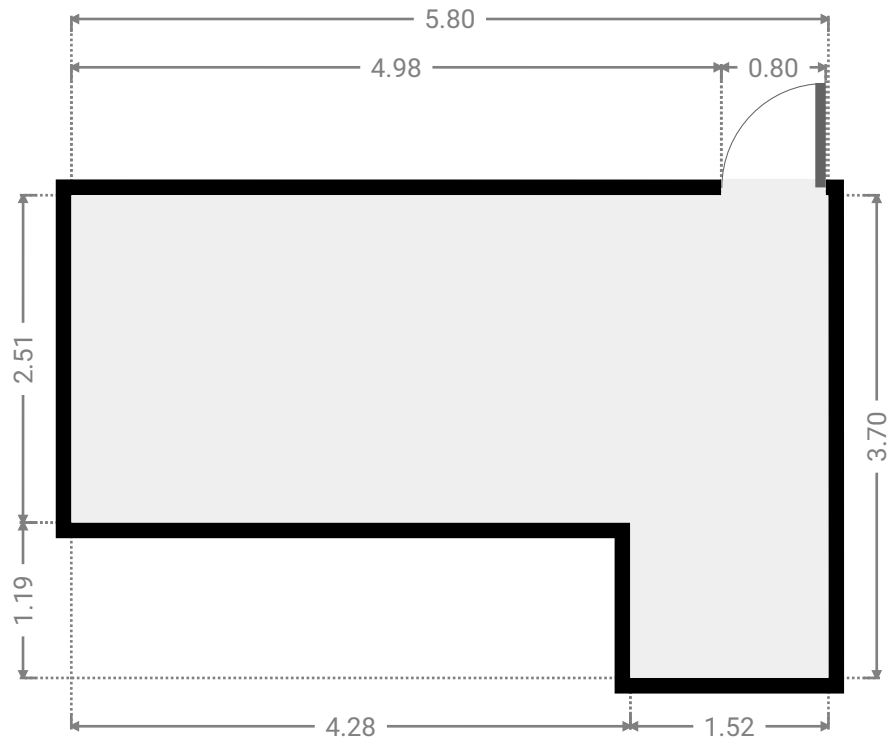
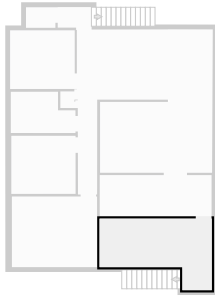

▼ **Toilet**  
1st Floor

WIDTH: 1.52 m • LENGTH: 1.06 m  
AREA: 1.61 m<sup>2</sup> • PERIMETER: 5.16 m

