

# 14 Webster Street

**SUBMITTED BY**

Ray White Rockhampton Casey  
stockers@cqoz.com

---

**CREATED ON**

2020-05-21

---

**Floors**

2

---

▼ Ground Floor



▼ **Bathroom**  
Ground Floor

WIDTH: 1.97 m • LENGTH: 2.50 m  
AREA: 4.92 m<sup>2</sup> • PERIMETER: 8.94 m

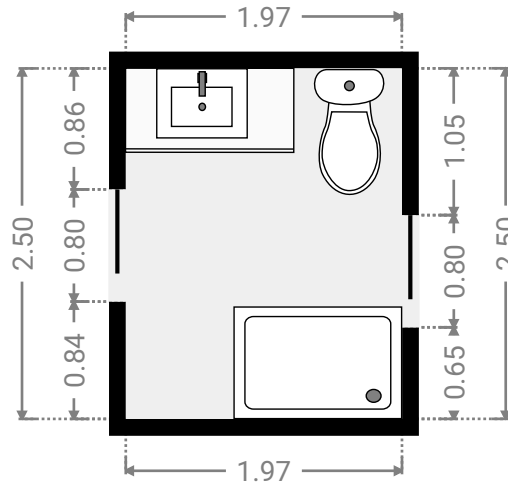
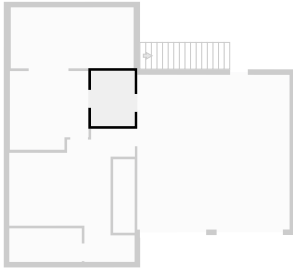

▼ **Bedroom**  
Ground Floor

WIDTH: 3.56 m • LENGTH: 3.56 m  
AREA: 12.07 m<sup>2</sup> • PERIMETER: 14.25 m

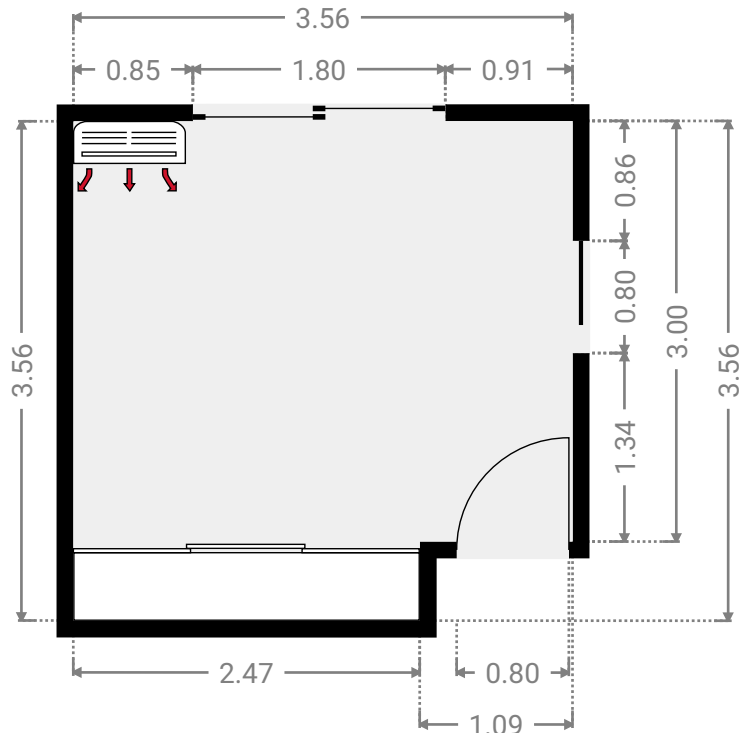
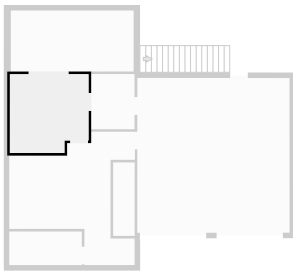

FLOORS: 2

▼ **Garage**  
Ground Floor

WIDTH: 6.90 m • LENGTH: 7.01 m  
AREA: 48.29 m<sup>2</sup> • PERIMETER: 27.80 m

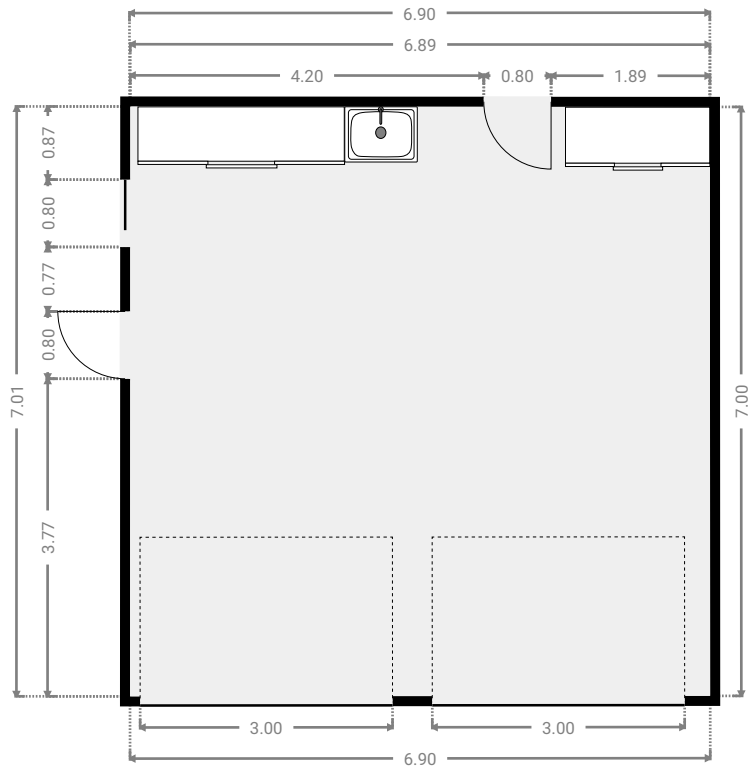
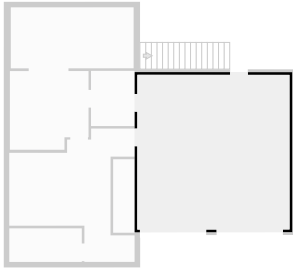

▼ **Living Room**  
Ground Floor

WIDTH: 5.69 m • LENGTH: 6.04 m  
AREA: 21.38 m<sup>2</sup> • PERIMETER: 25.63 m

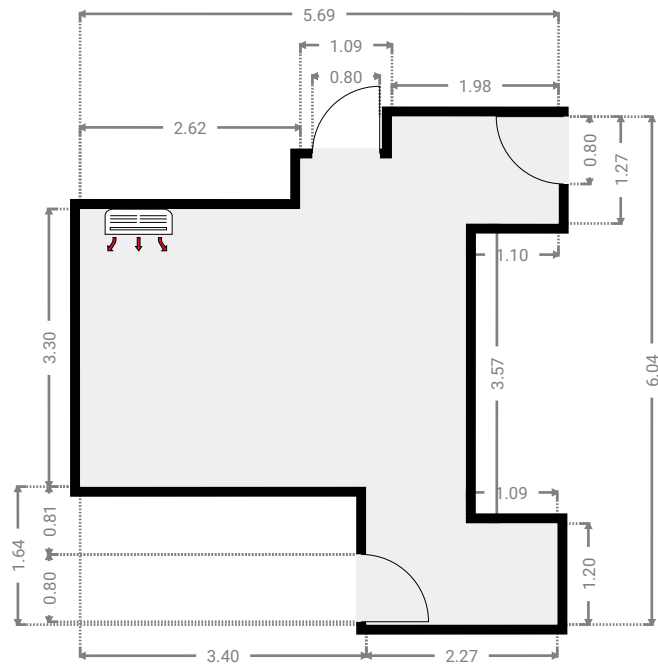
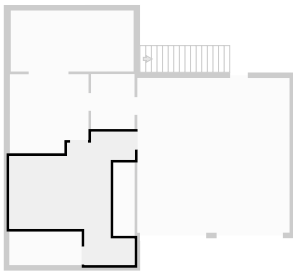

▼ Other  
Ground Floor

WIDTH: 5.56 m • LENGTH: 2.76 m  
AREA: 15.35 m<sup>2</sup> • PERIMETER: 16.64 m

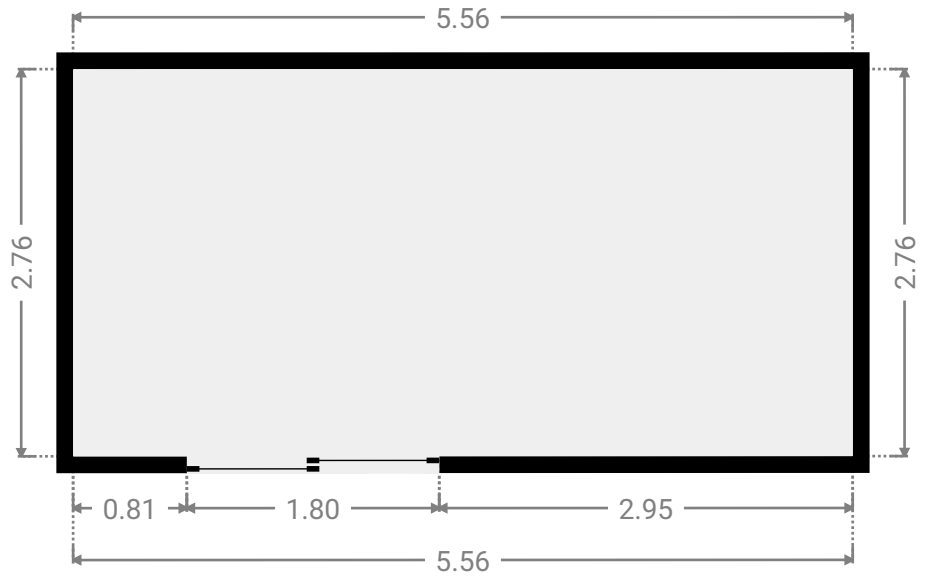
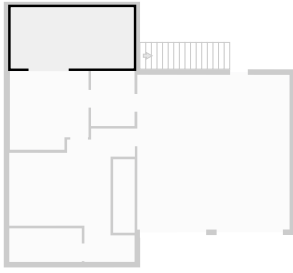

▼ Other  
Ground Floor

WIDTH: 3.28 m • LENGTH: 1.52 m  
AREA: 4.99 m<sup>2</sup> • PERIMETER: 9.60 m

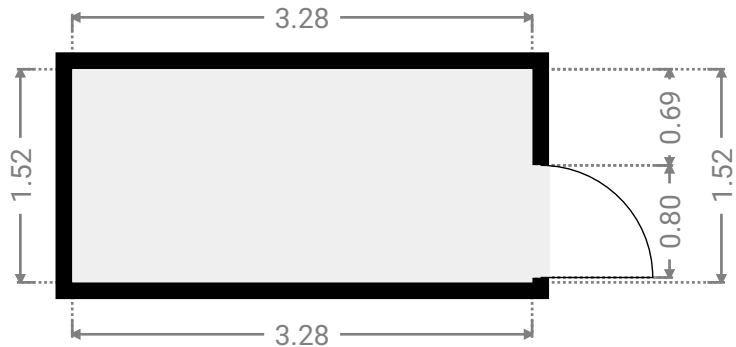
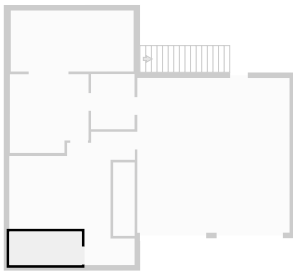

▼ **Stairway**  
Ground Floor

WIDTH: 0.97 m • LENGTH: 3.33 m  
AREA: 3.24 m<sup>2</sup> • PERIMETER: 8.60 m

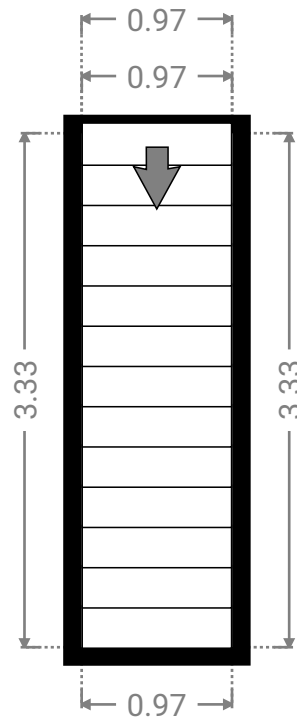
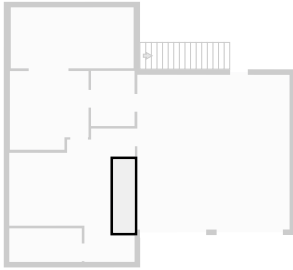

▼ 1st Floor

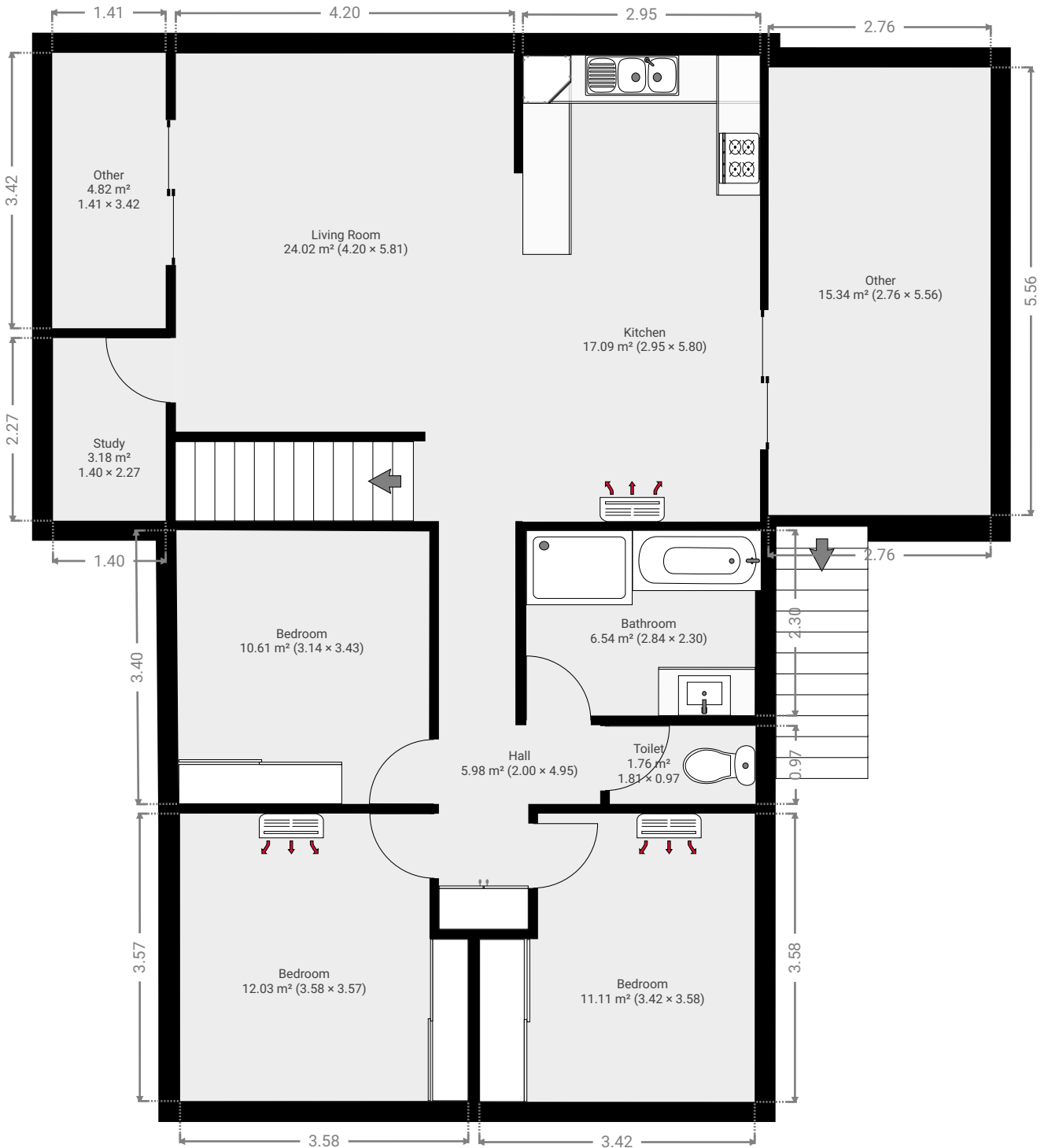

▼ Bathroom  
1st Floor

WIDTH: 2.30 m • LENGTH: 2.84 m  
AREA: 6.54 m<sup>2</sup> • PERIMETER: 10.28 m

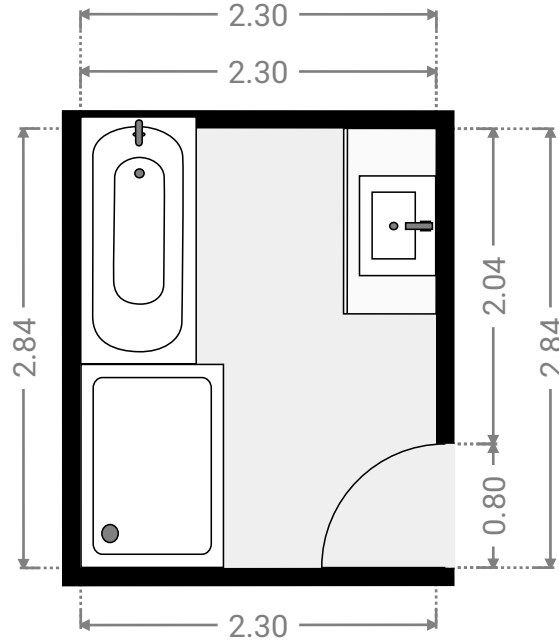
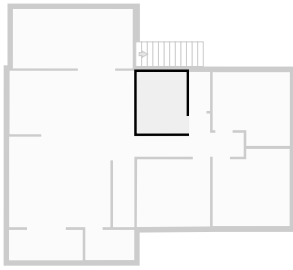

▼ Bedroom  
1st Floor

WIDTH: 3.58 m • LENGTH: 3.42 m  
AREA: 11.11 m<sup>2</sup> • PERIMETER: 14.00 m

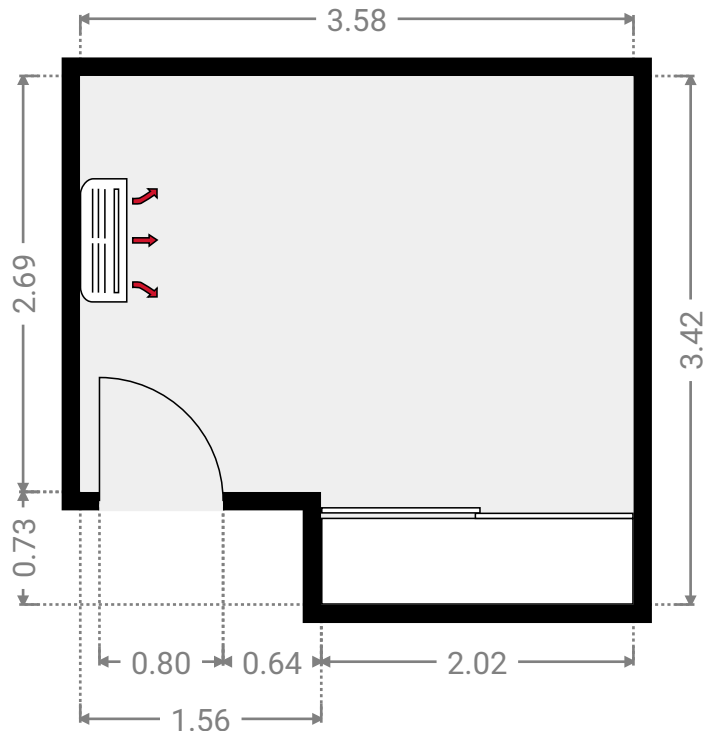
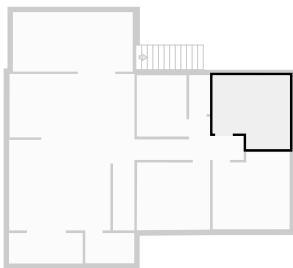



▼ **Bedroom**  
1st Floor

WIDTH: 3.57 m • LENGTH: 3.58 m  
AREA: 12.03 m<sup>2</sup> • PERIMETER: 14.30 m

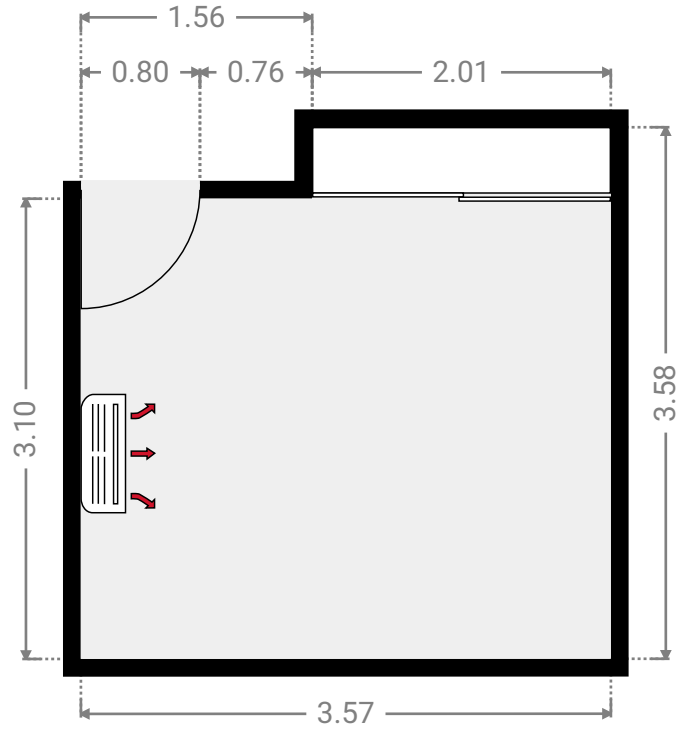
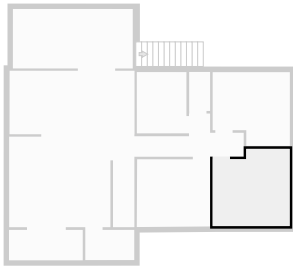

▼ **Bedroom**  
1st Floor

WIDTH: 3.43 m • LENGTH: 3.14 m  
AREA: 10.61 m<sup>2</sup> • PERIMETER: 13.04 m

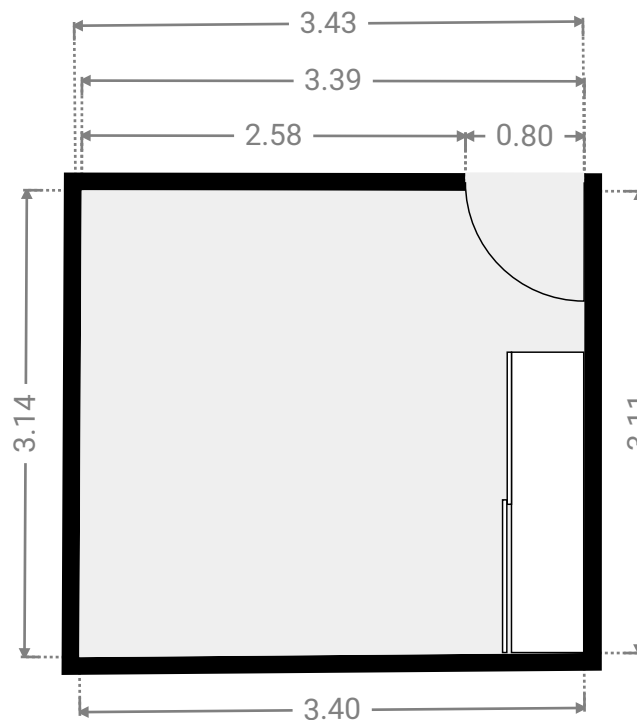
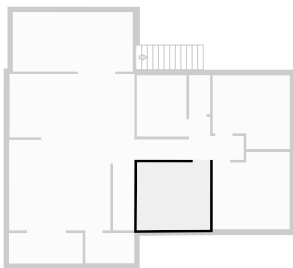

FLOORS: 2

▼ **Hall**  
1st Floor

WIDTH: 4.95 m • LENGTH: 2.00 m  
AREA: 5.98 m<sup>2</sup> • PERIMETER: 13.90 m

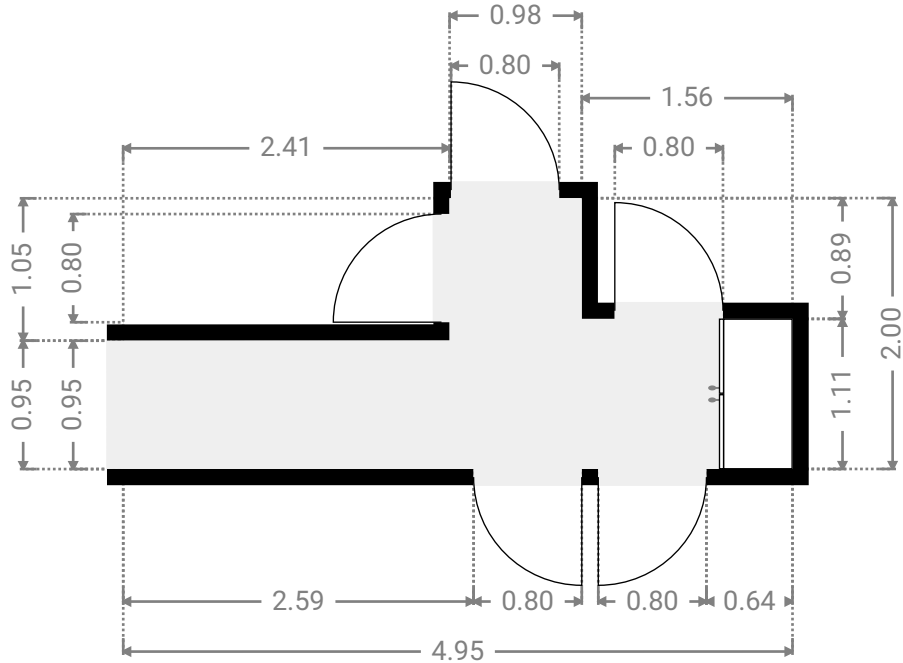
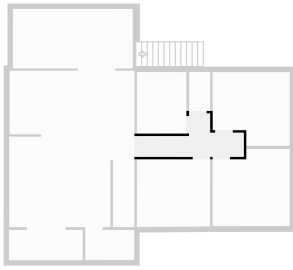

▼ **Kitchen**  
1st Floor

WIDTH: 5.80 m • LENGTH: 2.95 m  
AREA: 17.09 m<sup>2</sup> • PERIMETER: 17.49 m

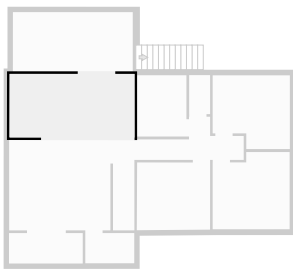

▼ **Living Room**  
1st Floor

WIDTH: 5.81 m • LENGTH: 4.20 m  
AREA: 24.02 m<sup>2</sup> • PERIMETER: 26.22 m

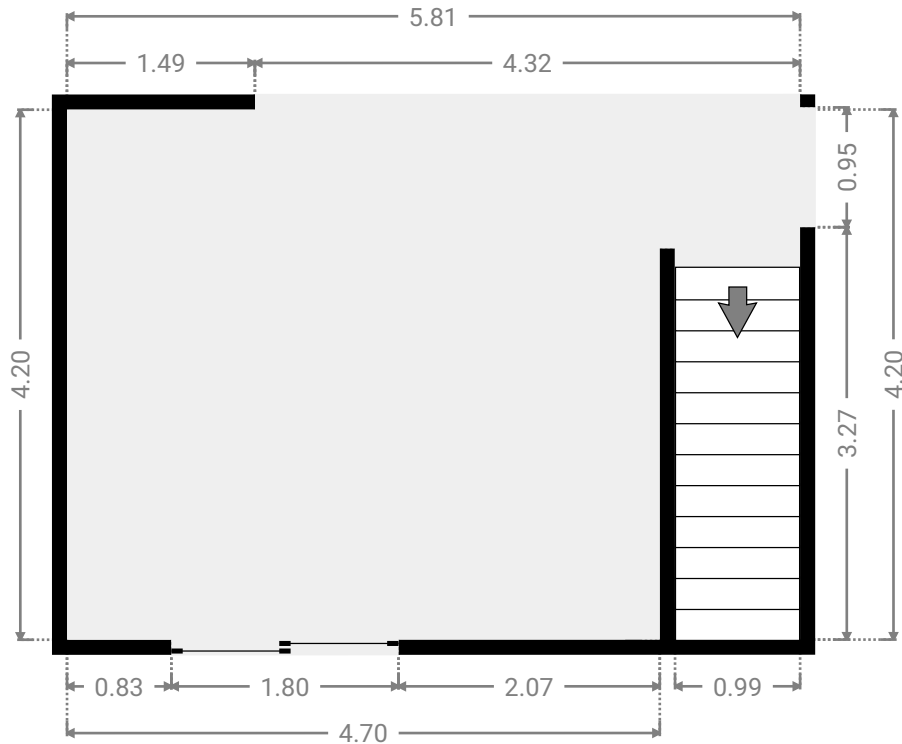
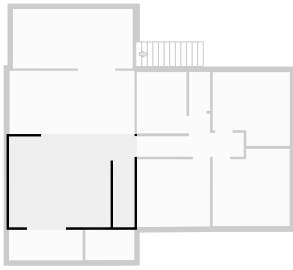

▼ **Other**  
1st Floor

WIDTH: 3.42 m • LENGTH: 1.41 m  
AREA: 4.82 m<sup>2</sup> • PERIMETER: 9.66 m

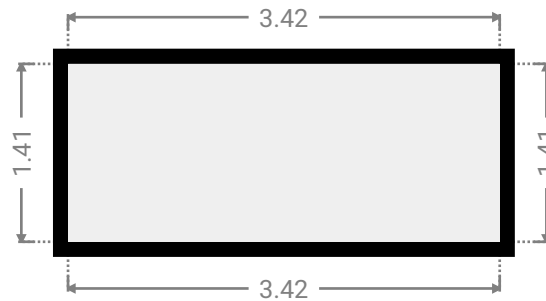
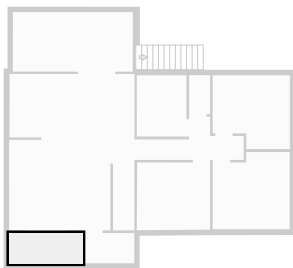

▼ **Other**  
1st Floor

WIDTH: 5.56 m • LENGTH: 2.76 m  
AREA: 15.34 m<sup>2</sup> • PERIMETER: 16.64 m

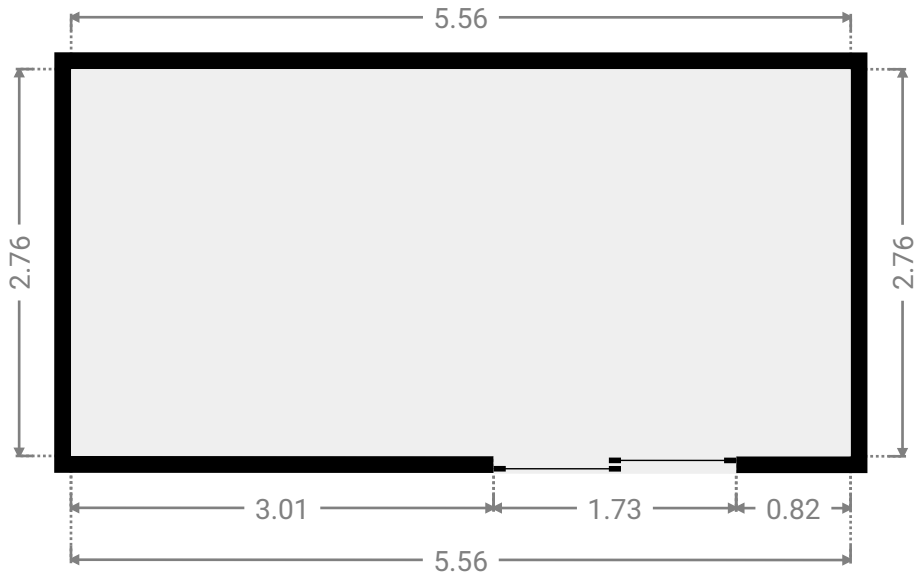
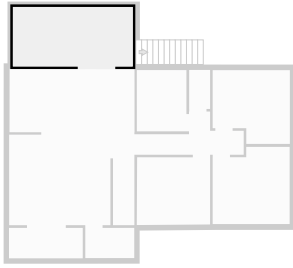

▼ **Study**  
1st Floor

WIDTH: 2.27 m • LENGTH: 1.40 m  
AREA: 3.18 m<sup>2</sup> • PERIMETER: 7.34 m

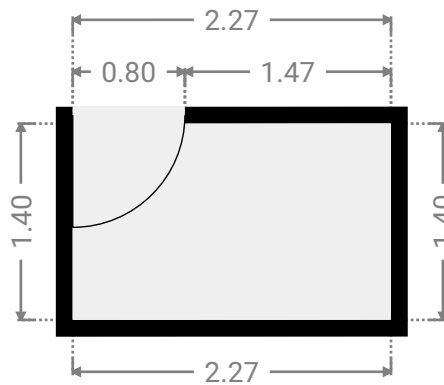
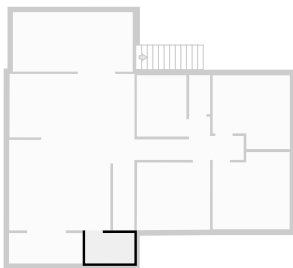

▼ Toilet  
1st Floor

WIDTH: 0.97 m • LENGTH: 1.81 m  
AREA: 1.76 m<sup>2</sup> • PERIMETER: 5.56 m

