

14 Jefferies Street

SUBMITTED BY

Ray White Rockhampton Casey
stockers@cqoz.com

CREATED ON

2022-12-01

Floors

1

▼ Ground Floor



▼ Bathroom
Ground Floor

WIDTH: 2.76 m • LENGTH: 3.15 m
AREA: 8.70 m² • PERIMETER: 11.83 m

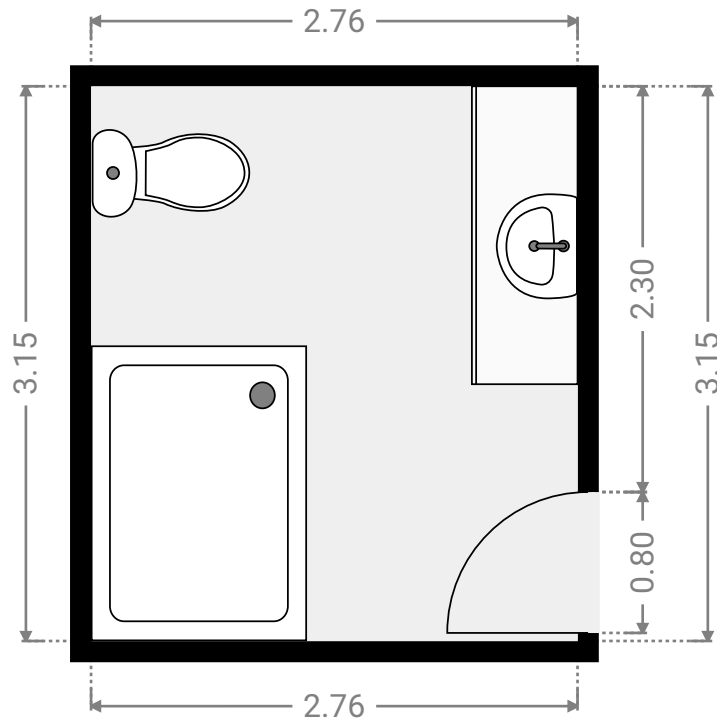

▼ Bathroom
Ground Floor

WIDTH: 3.24 m • LENGTH: 2.00 m
AREA: 6.48 m² • PERIMETER: 10.48 m

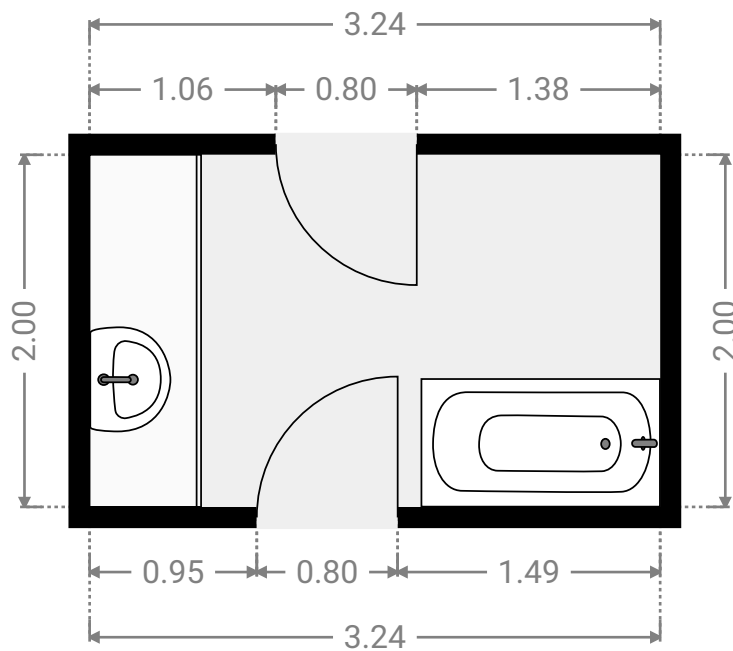
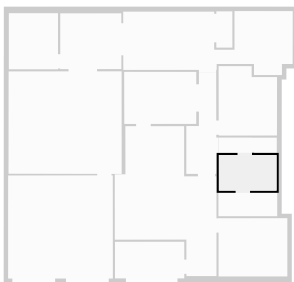

FLOORS: 1

▼ Closet
Ground Floor

WIDTH: 3.30 m • LENGTH: 1.32 m
AREA: 4.35 m² • PERIMETER: 9.24 m

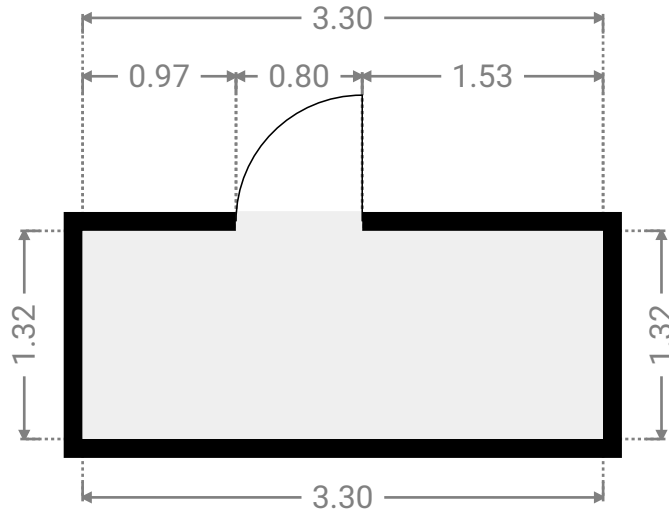

▼ Bedroom
Ground Floor

WIDTH: 3.27 m • LENGTH: 3.59 m
AREA: 10.67 m² • PERIMETER: 13.71 m

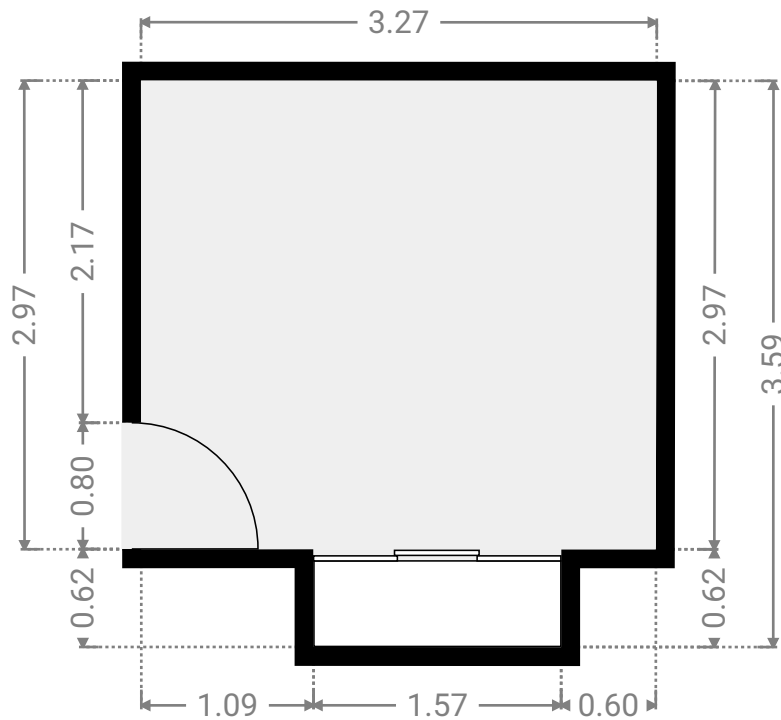
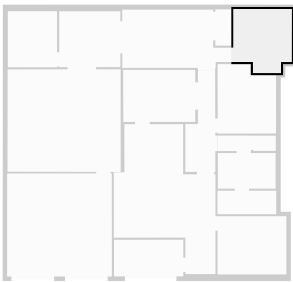

FLOORS: 1

▼ **Bedroom**
Ground Floor

WIDTH: 3.28 m • LENGTH: 3.90 m
AREA: 11.89 m² • PERIMETER: 14.34 m

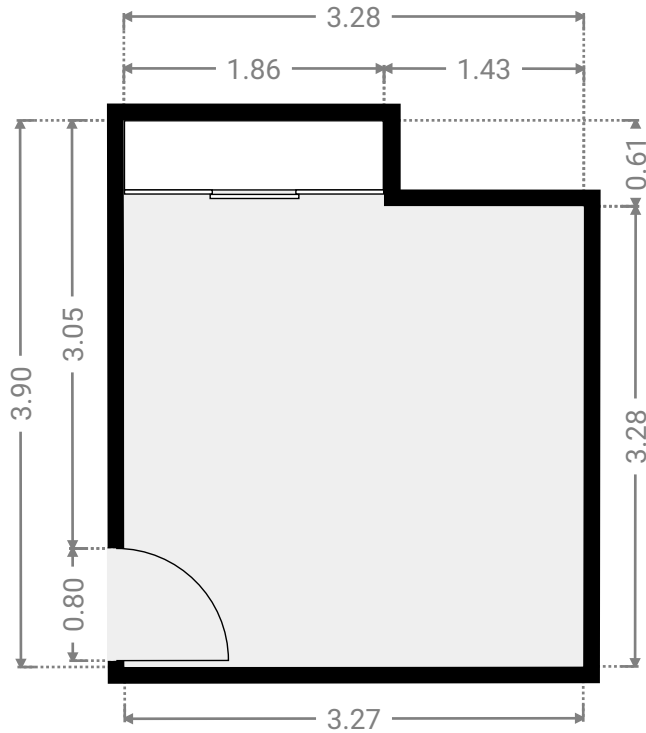
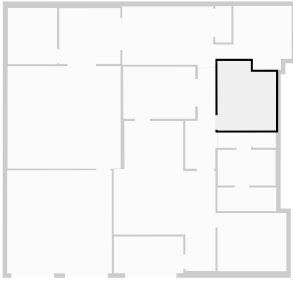

▼ **Bedroom**
Ground Floor

WIDTH: 3.86 m • LENGTH: 3.27 m
AREA: 12.62 m² • PERIMETER: 14.26 m

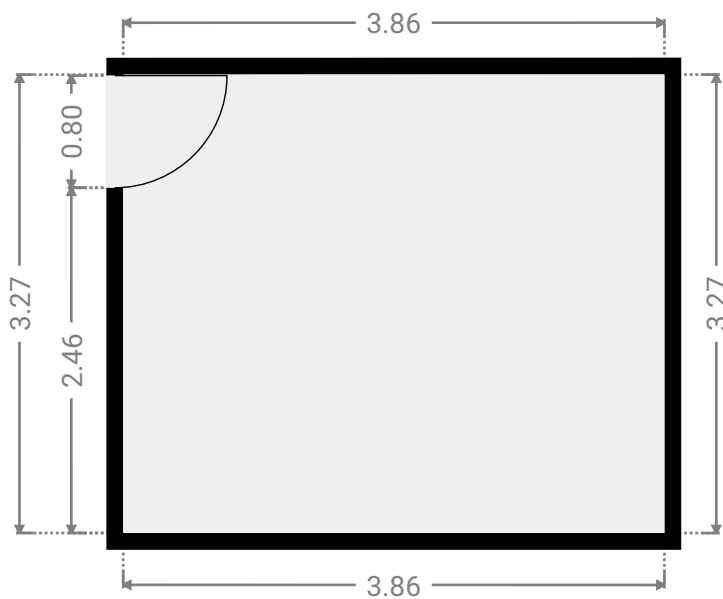

FLOORS: 1

▼ Dining Room
Ground Floor

WIDTH: 6.15 m • LENGTH: 3.27 m
AREA: 17.57 m² • PERIMETER: 18.83 m

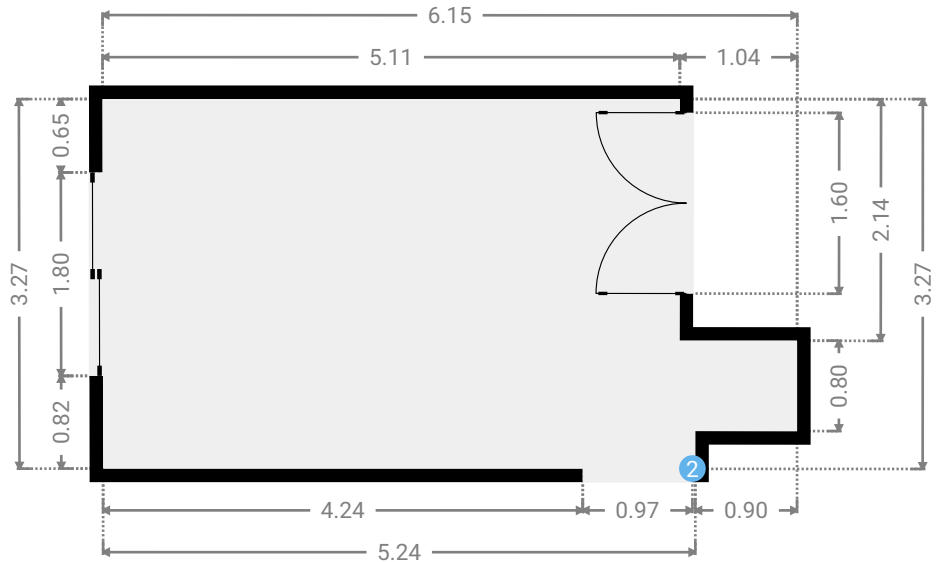
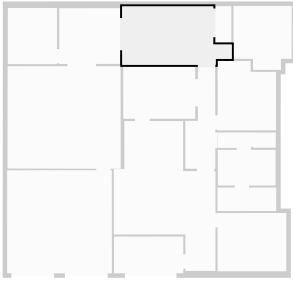

▼ Closet
Ground Floor

WIDTH: 0.90 m • LENGTH: 2.03 m
AREA: 1.83 m² • PERIMETER: 5.87 m

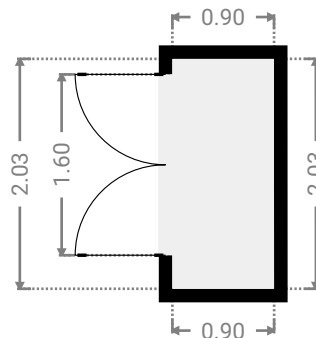
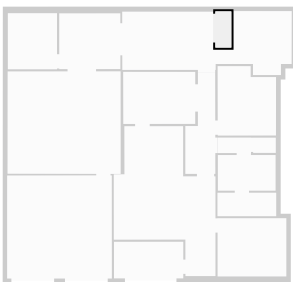

▼ Hall/Ground Floor

2 OPENING

Height
0.00 m



FLOORS: 1

▼ **Hall**
Ground Floor

WIDTH: 1.86 m • LENGTH: 0.87 m
AREA: 1.62 m² • PERIMETER: 5.46 m

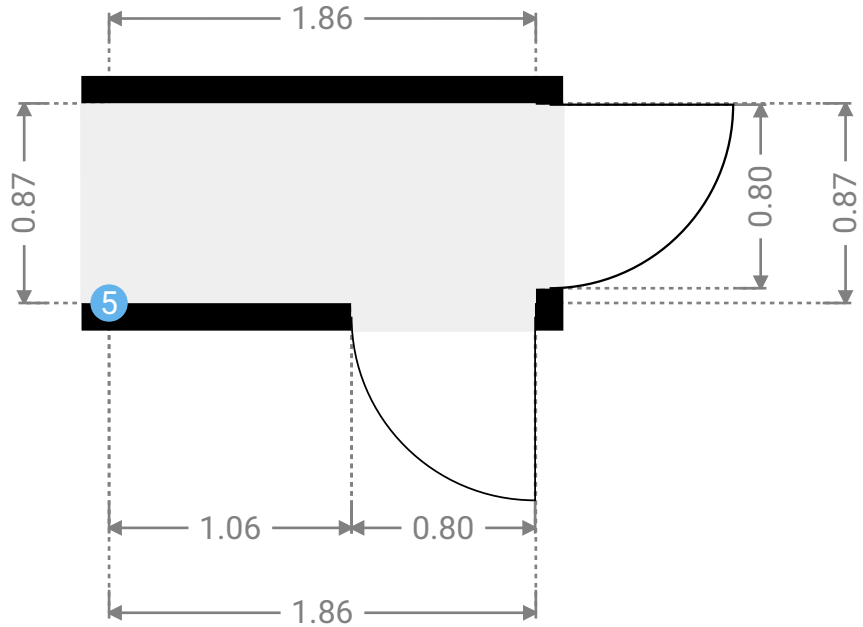

▼ **Hall/Ground Floor**

5 OPENING

Height
0.00 m



▼ **Kitchen**
Ground Floor

WIDTH: 4.05 m • LENGTH: 2.92 m
AREA: 11.82 m² • PERIMETER: 13.93 m

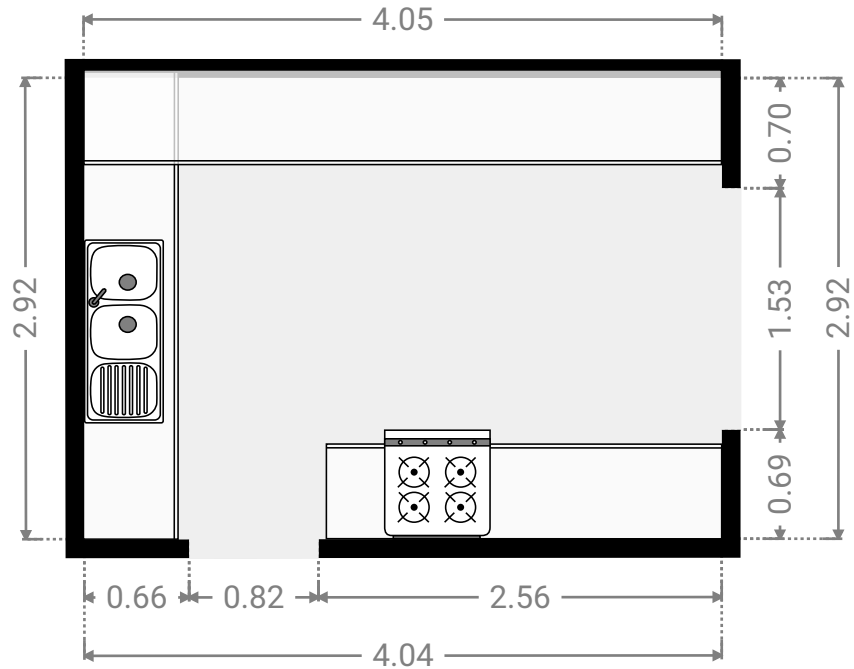
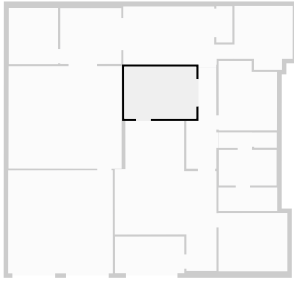

▼ **Laundry Room**
Ground Floor

WIDTH: 3.43 m • LENGTH: 3.13 m
AREA: 10.74 m² • PERIMETER: 13.12 m

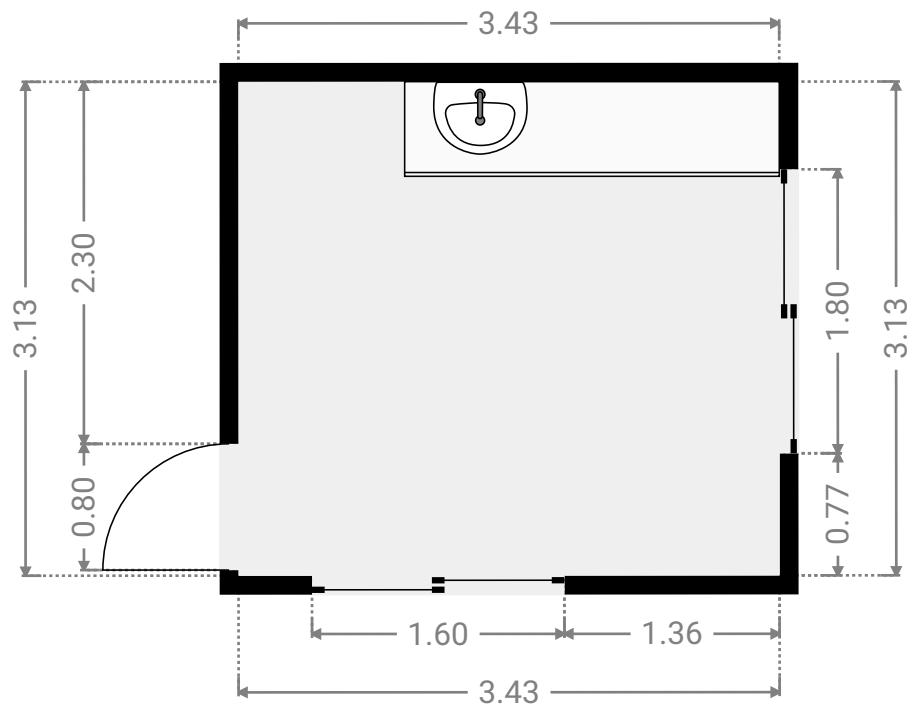
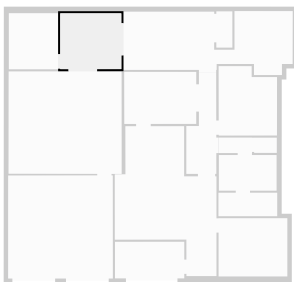

FLOORS: 1

▼ Living Room
Ground Floor

WIDTH: 5.71 m • LENGTH: 8.42 m
AREA: 33.10 m² • PERIMETER: 28.26 m

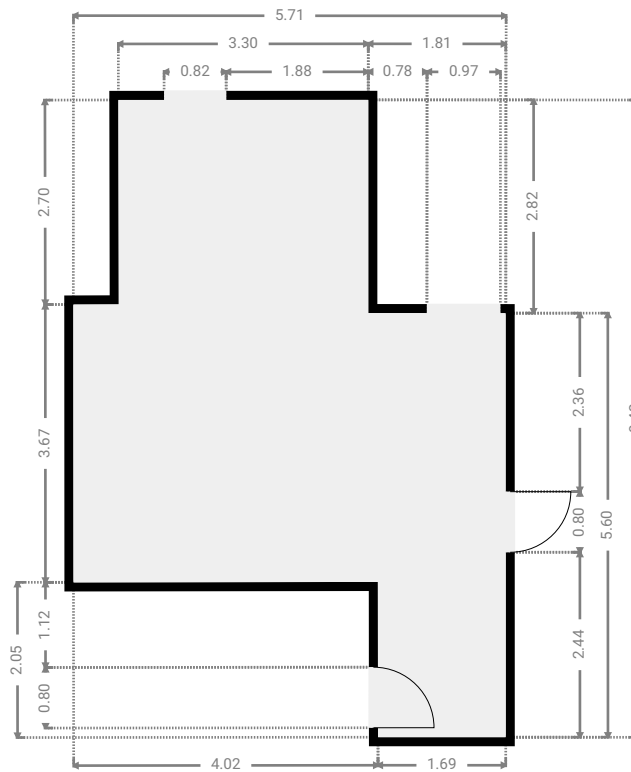
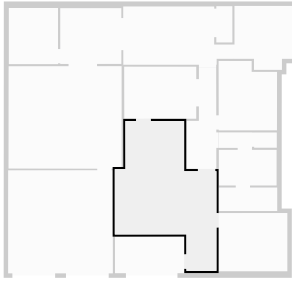

▼ Other
Ground Floor

WIDTH: 6.35 m • LENGTH: 5.76 m
AREA: 36.51 m² • PERIMETER: 24.20 m

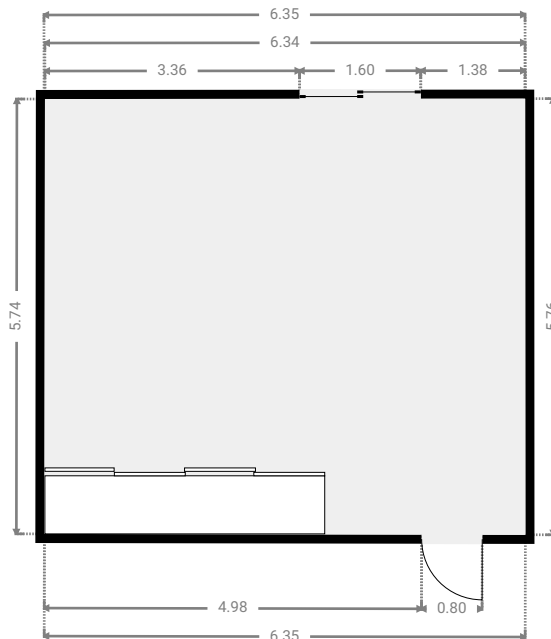
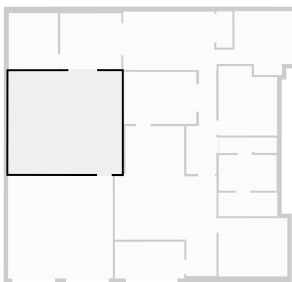

FLOORS: 1

▼ **Other**
Ground Floor

WIDTH: 3.89 m • LENGTH: 2.05 m
AREA: 7.99 m² • PERIMETER: 11.89 m

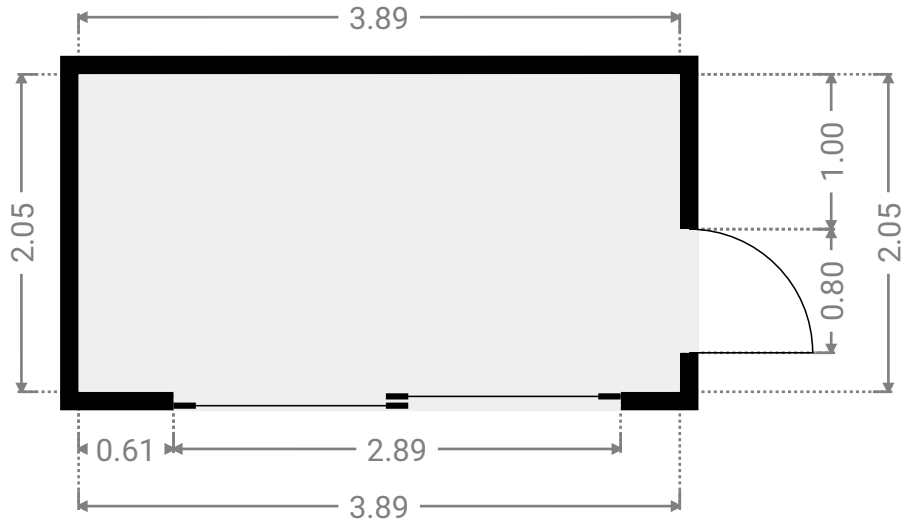

▼ **Toilet**
Ground Floor

WIDTH: 1.27 m • LENGTH: 0.85 m
AREA: 1.09 m² • PERIMETER: 4.25 m

