

1/14 Herbert STREET

SUBMITTED BY

Ray White Rockhampton Casey
stockers@cqoz.com

CREATED ON

2022-09-21

Floors

2

▼ Ground Floor

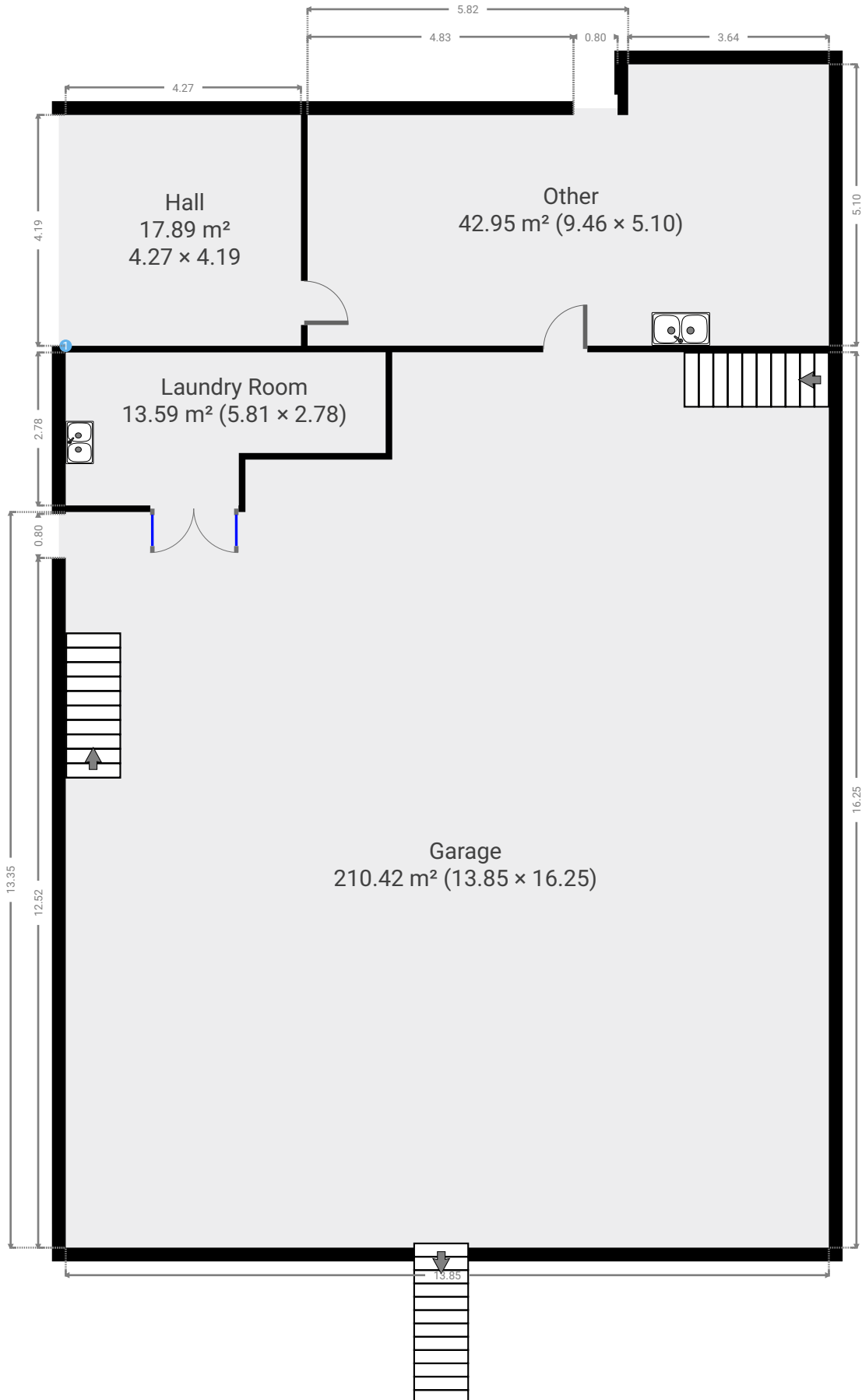

▼ **Garage**
Ground Floor

WIDTH: 13.85 m • LENGTH: 16.25 m
AREA: 210.42 m² • PERIMETER: 60.20 m

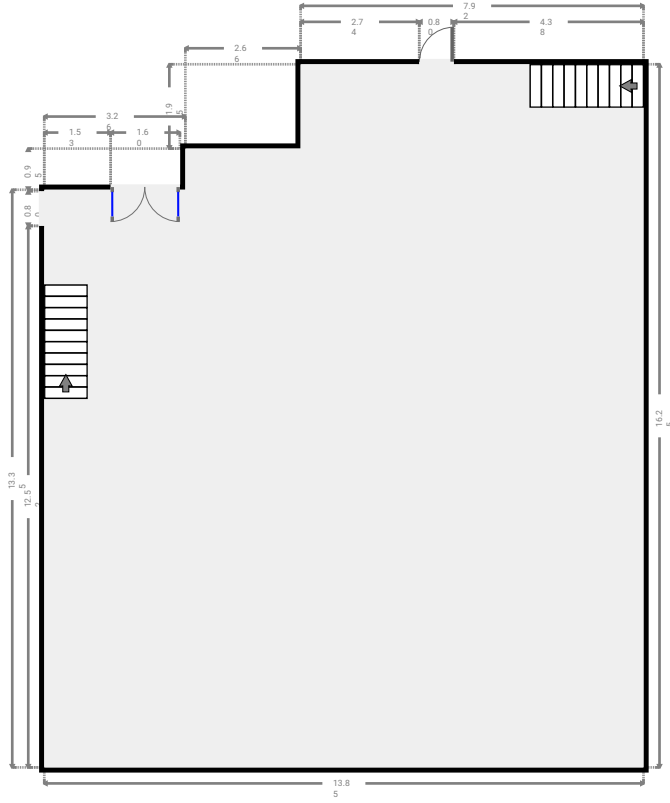
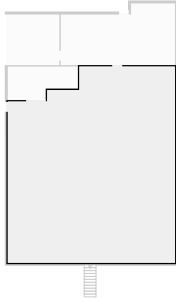

▼ **Hall**
Ground Floor

WIDTH: 4.27 m • LENGTH: 4.19 m
AREA: 17.89 m² • PERIMETER: 16.92 m

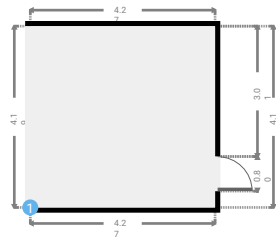
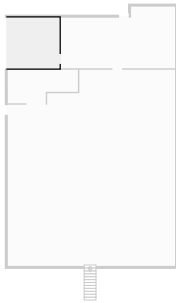

▼ **Hall**/Ground Floor

1 OPENING

Height
0.00 m



▼ Laundry Room
Ground Floor

WIDTH: 5.81 m • LENGTH: 2.78 m
AREA: 13.59 m² • PERIMETER: 17.17 m

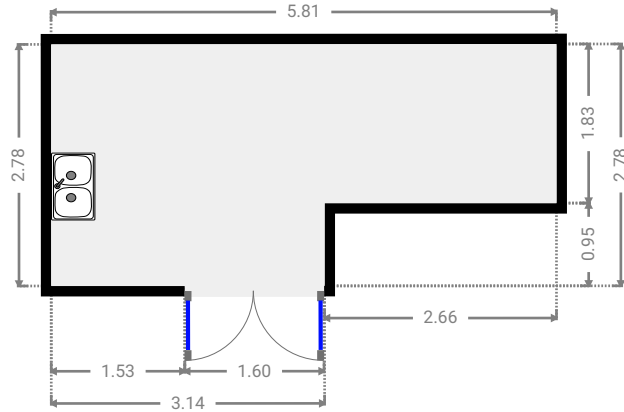
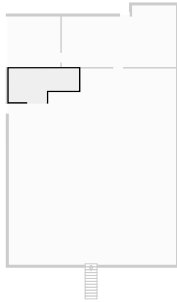

▼ Other
Ground Floor

WIDTH: 9.46 m • LENGTH: 5.10 m
AREA: 42.95 m² • PERIMETER: 29.13 m

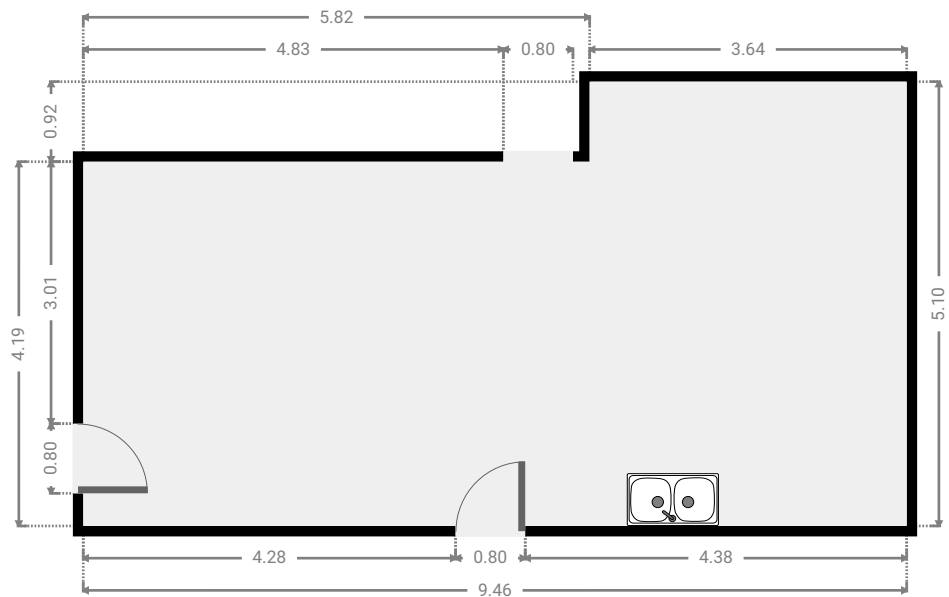
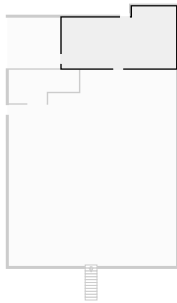

▼ 1st Floor

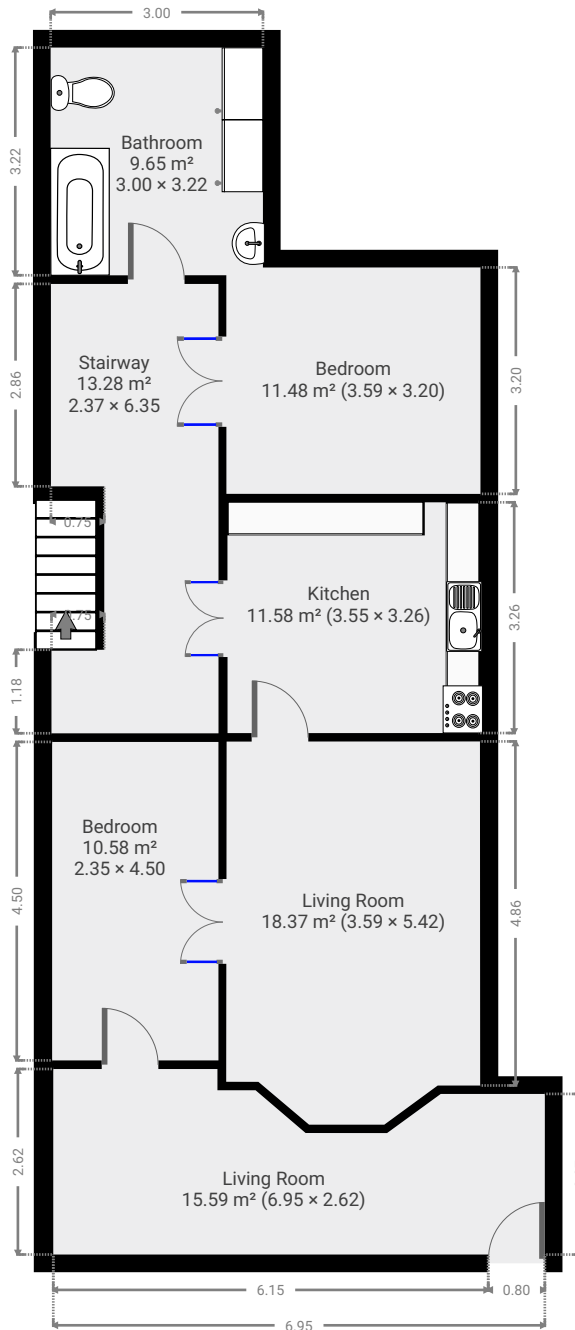

▼ **Bathroom**
1st Floor

WIDTH: 3.00 m • LENGTH: 3.22 m
AREA: 9.65 m² • PERIMETER: 12.43 m

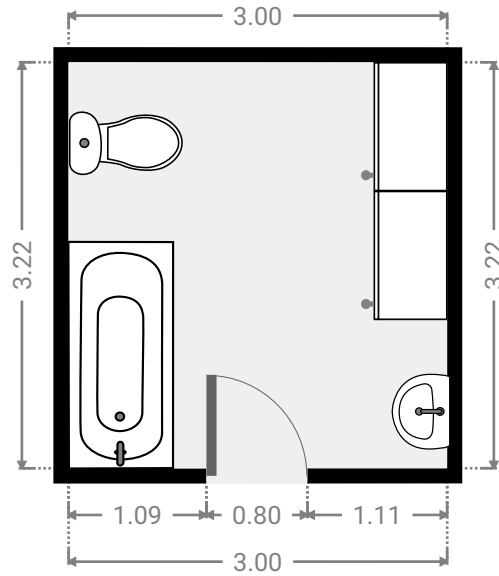

▼ **Bedroom**
1st Floor

WIDTH: 2.35 m • LENGTH: 4.50 m
AREA: 10.58 m² • PERIMETER: 13.70 m

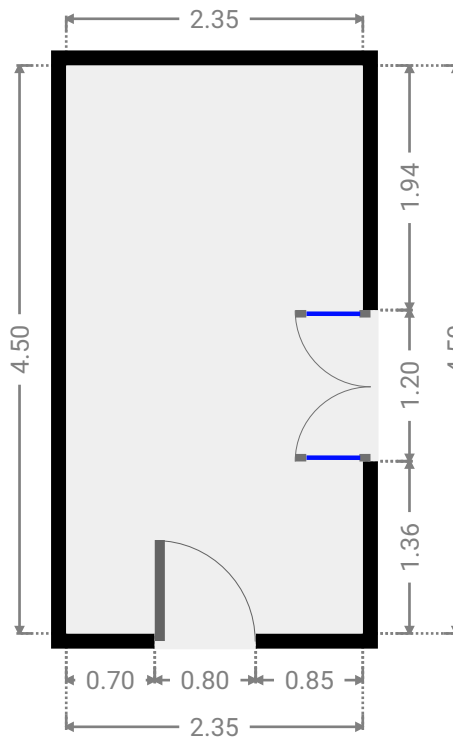

▼ **Bedroom**
1st Floor

WIDTH: 3.59 m • LENGTH: 3.20 m
AREA: 11.48 m² • PERIMETER: 13.58 m

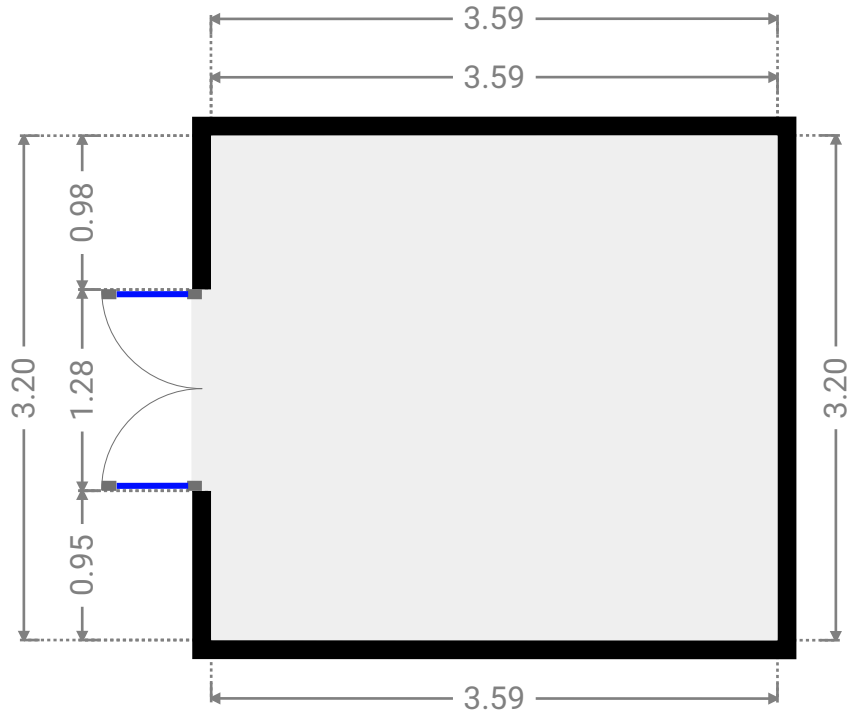
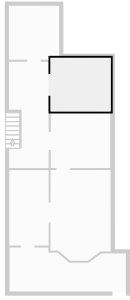

▼ **Kitchen**
1st Floor

WIDTH: 3.55 m • LENGTH: 3.26 m
AREA: 11.58 m² • PERIMETER: 13.62 m

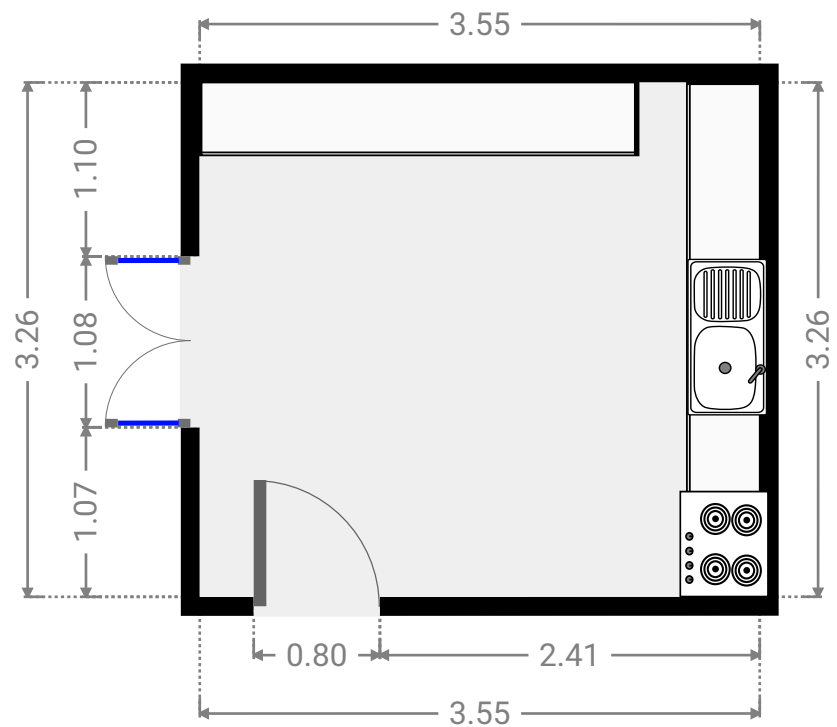
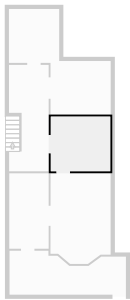

▼ Living Room
1st Floor

WIDTH: 6.95 m • LENGTH: 2.62 m
AREA: 15.59 m² • PERIMETER: 19.49 m

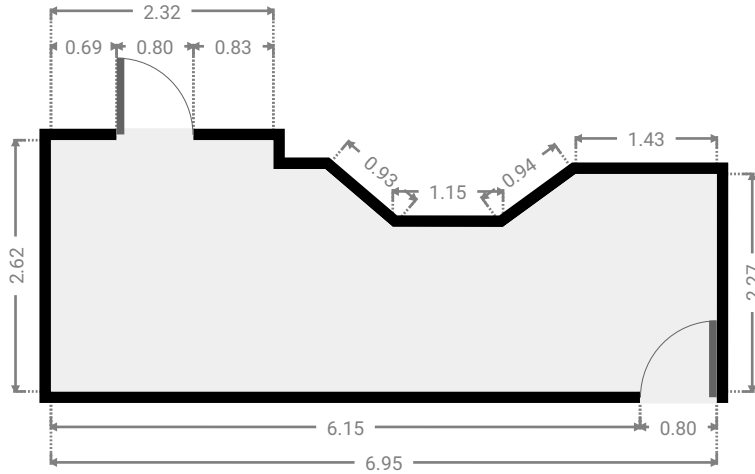

▼ Living Room
1st Floor

WIDTH: 3.59 m • LENGTH: 5.42 m
AREA: 18.37 m² • PERIMETER: 17.24 m

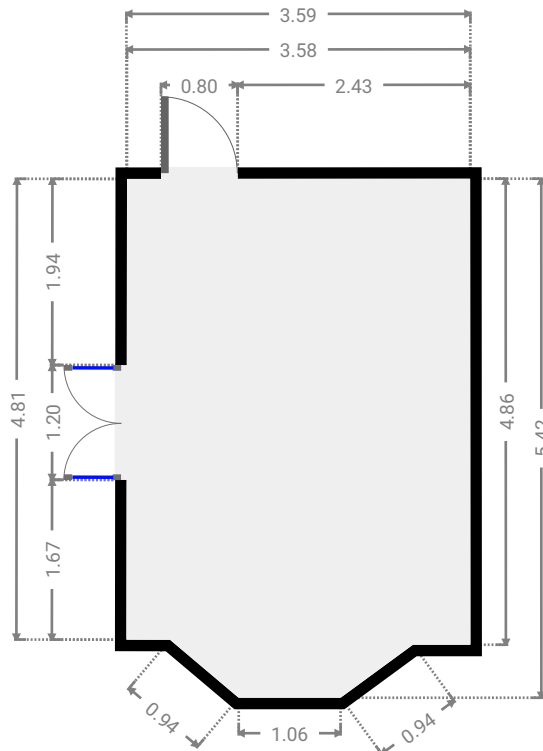

▼ Stairway
1st Floor

WIDTH: 2.37 m • LENGTH: 6.35 m
AREA: 13.28 m² • PERIMETER: 18.93 m

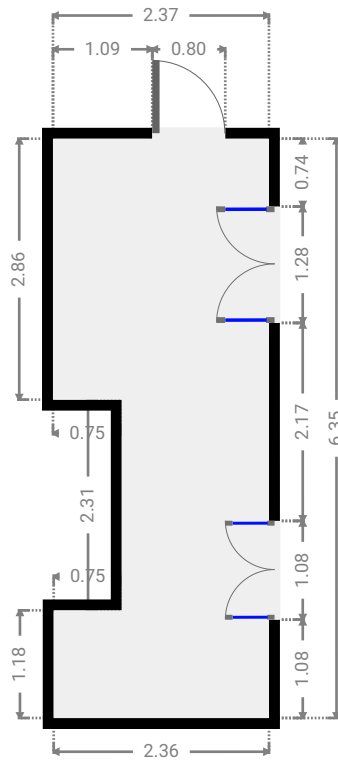
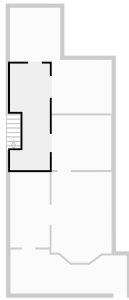

Unit 2/14 Herbert Street

SUBMITTED BY

Ray White Rockhampton Casey
stockers@cqoz.com

CREATED ON

2022-09-27

Floors

1

▼ 1st Floor

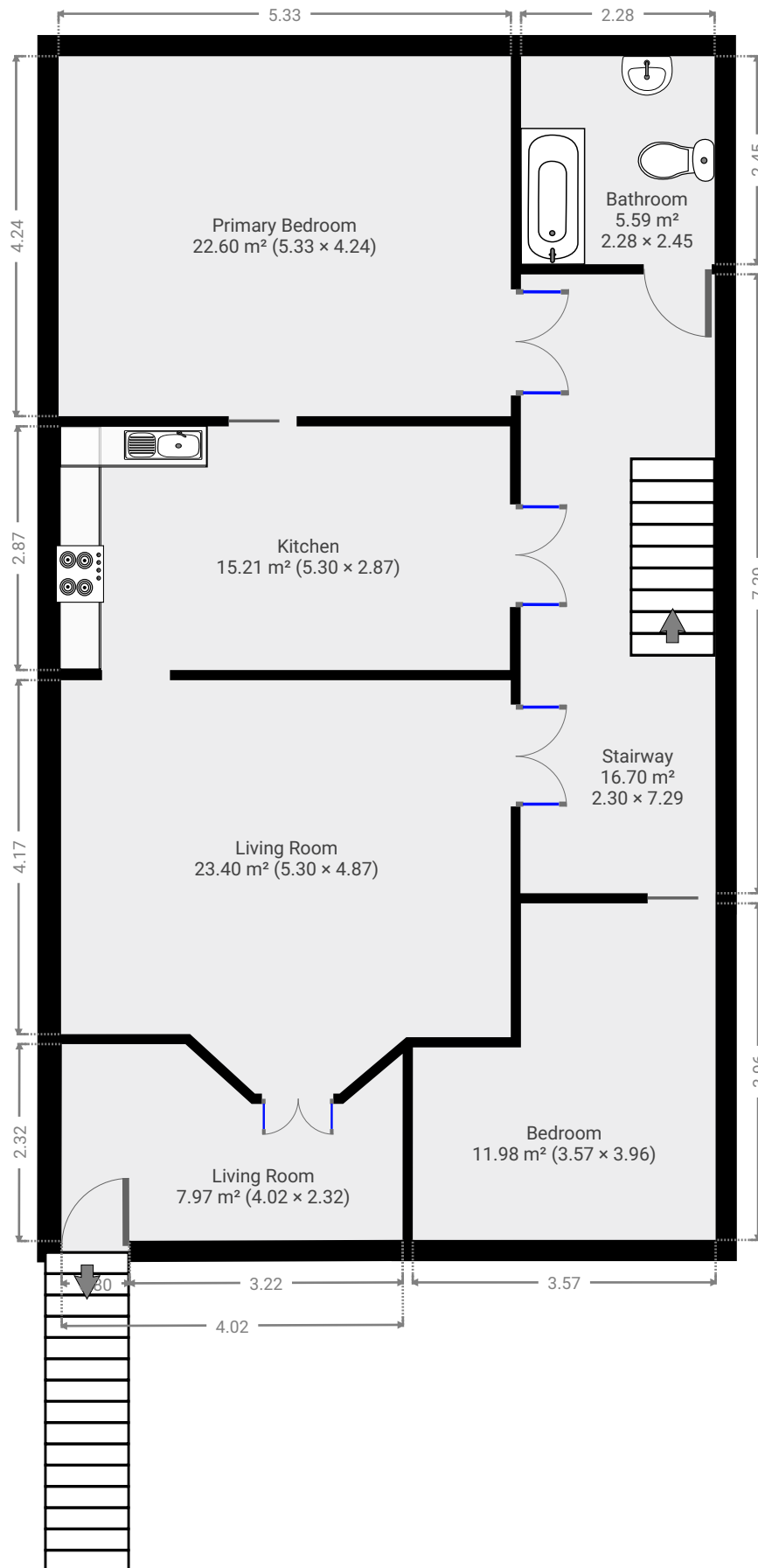

FLOORS: 1

▼ **Bathroom**
1st Floor

WIDTH: 2.28 m • LENGTH: 2.45 m
AREA: 5.59 m² • PERIMETER: 9.46 m

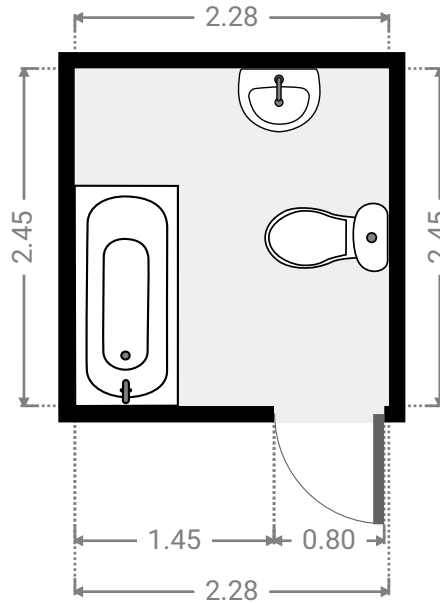
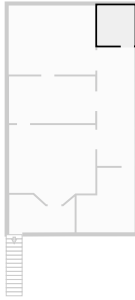

▼ **Bedroom**
1st Floor

WIDTH: 3.57 m • LENGTH: 3.96 m
AREA: 11.98 m² • PERIMETER: 15.06 m

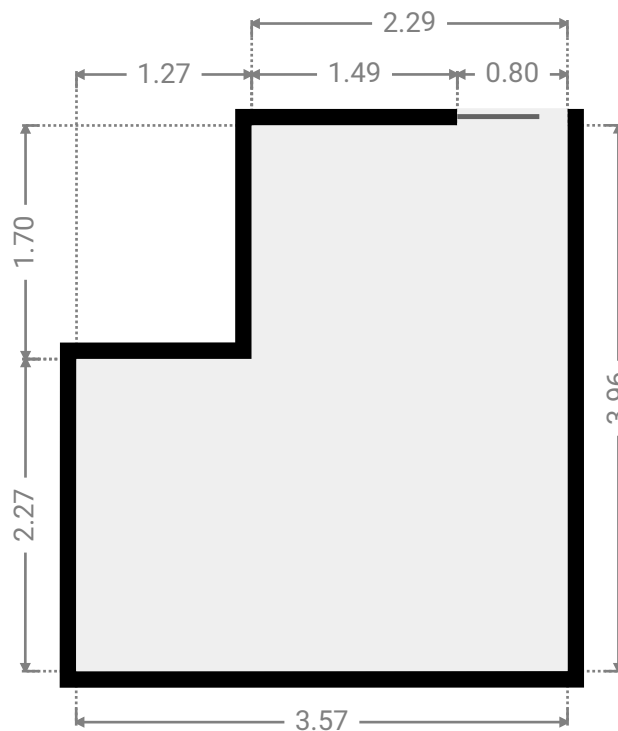

FLOORS: 1

▼ Kitchen
1st Floor

WIDTH: 5.30 m • LENGTH: 2.87 m
AREA: 15.21 m² • PERIMETER: 16.34 m

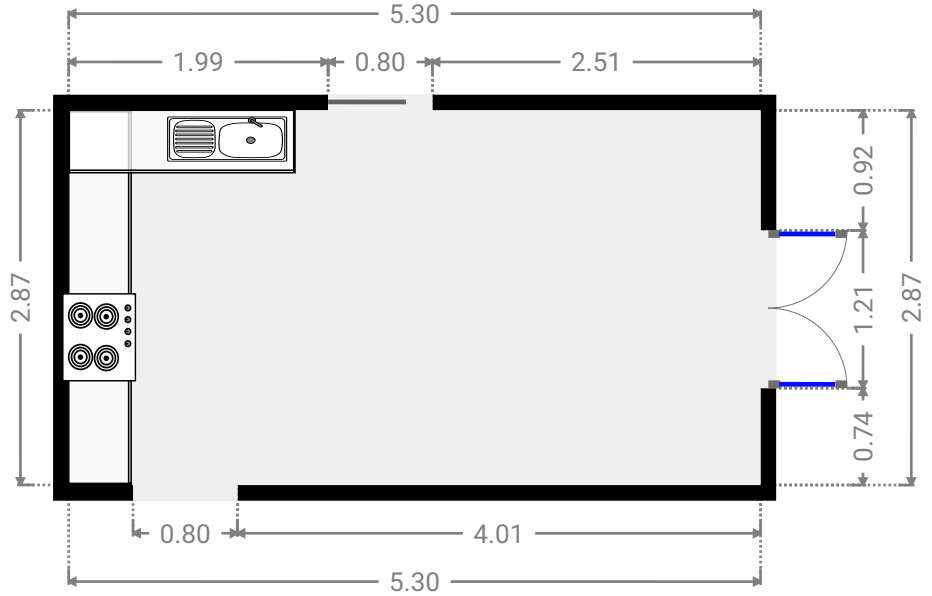
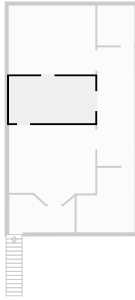

▼ Living Room
1st Floor

WIDTH: 4.02 m • LENGTH: 2.32 m
AREA: 7.97 m² • PERIMETER: 13.04 m

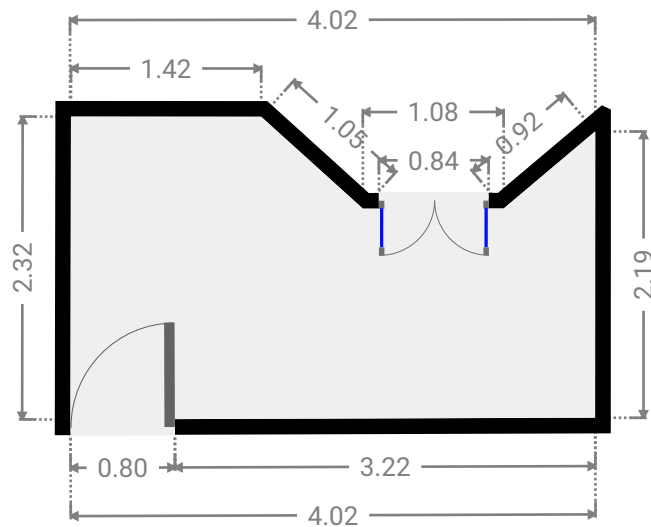
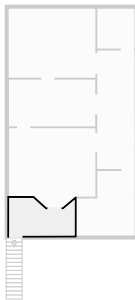

FLOORS: 1

▼ **Living Room**
1st Floor

WIDTH: 5.30 m • LENGTH: 4.87 m
AREA: 23.40 m² • PERIMETER: 19.49 m

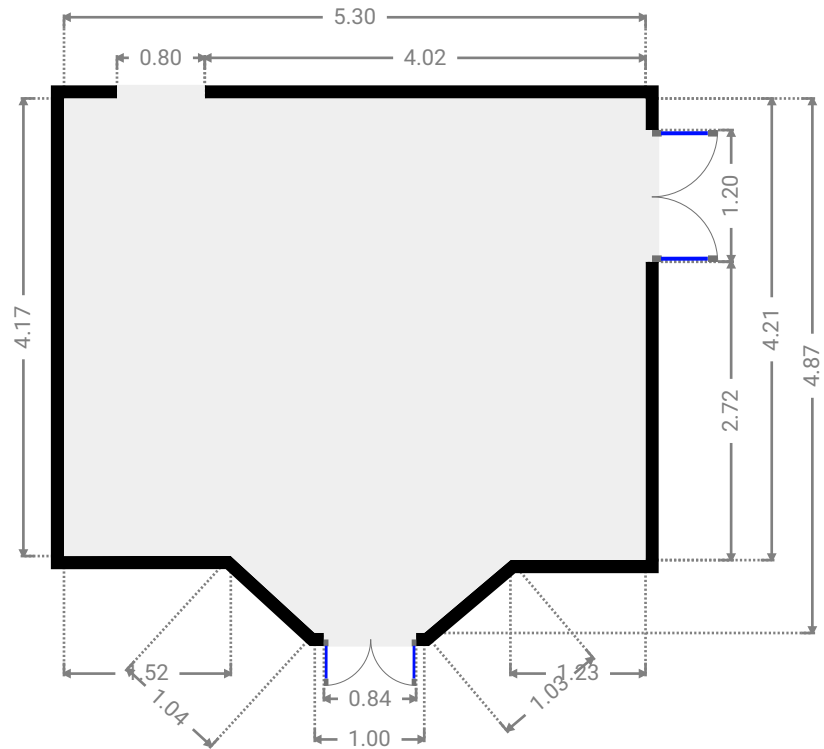
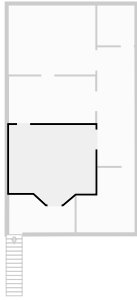

▼ **Primary Bedroom**
1st Floor

WIDTH: 5.33 m • LENGTH: 4.24 m
AREA: 22.60 m² • PERIMETER: 19.14 m

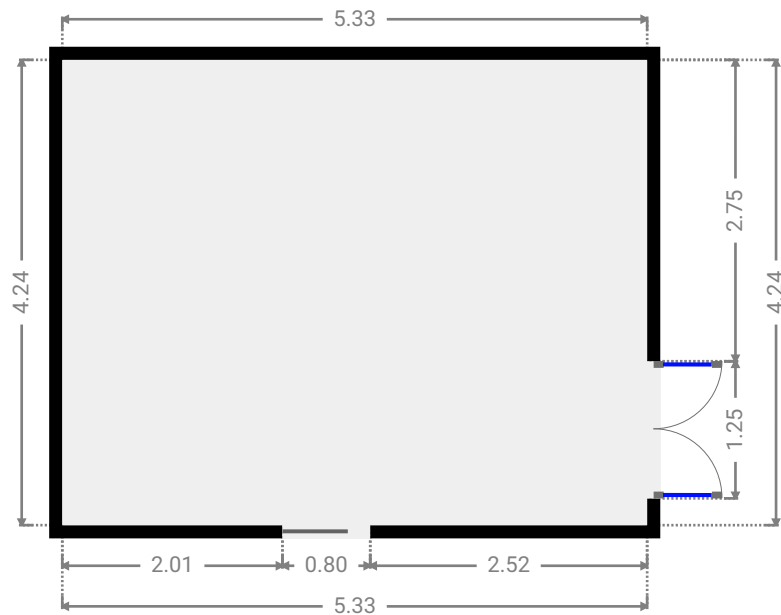

FLOORS: 1

▼ Stairway 1st Floor

WIDTH: 2.30 m • LENGTH: 7.29 m
AREA: 16.70 m² • PERIMETER: 19.16 m

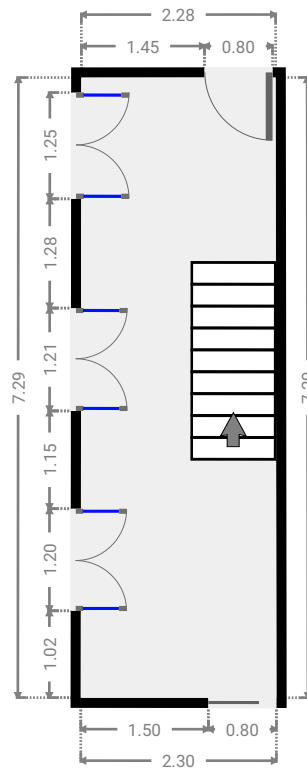
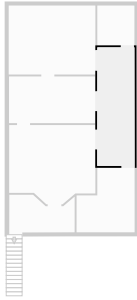

3/14 Herbert STREET

SUBMITTED BY

Ray White Rockhampton Casey
stockers@cqoz.com

CREATED ON

2022-09-27

Floors

1

▼ 1st Floor

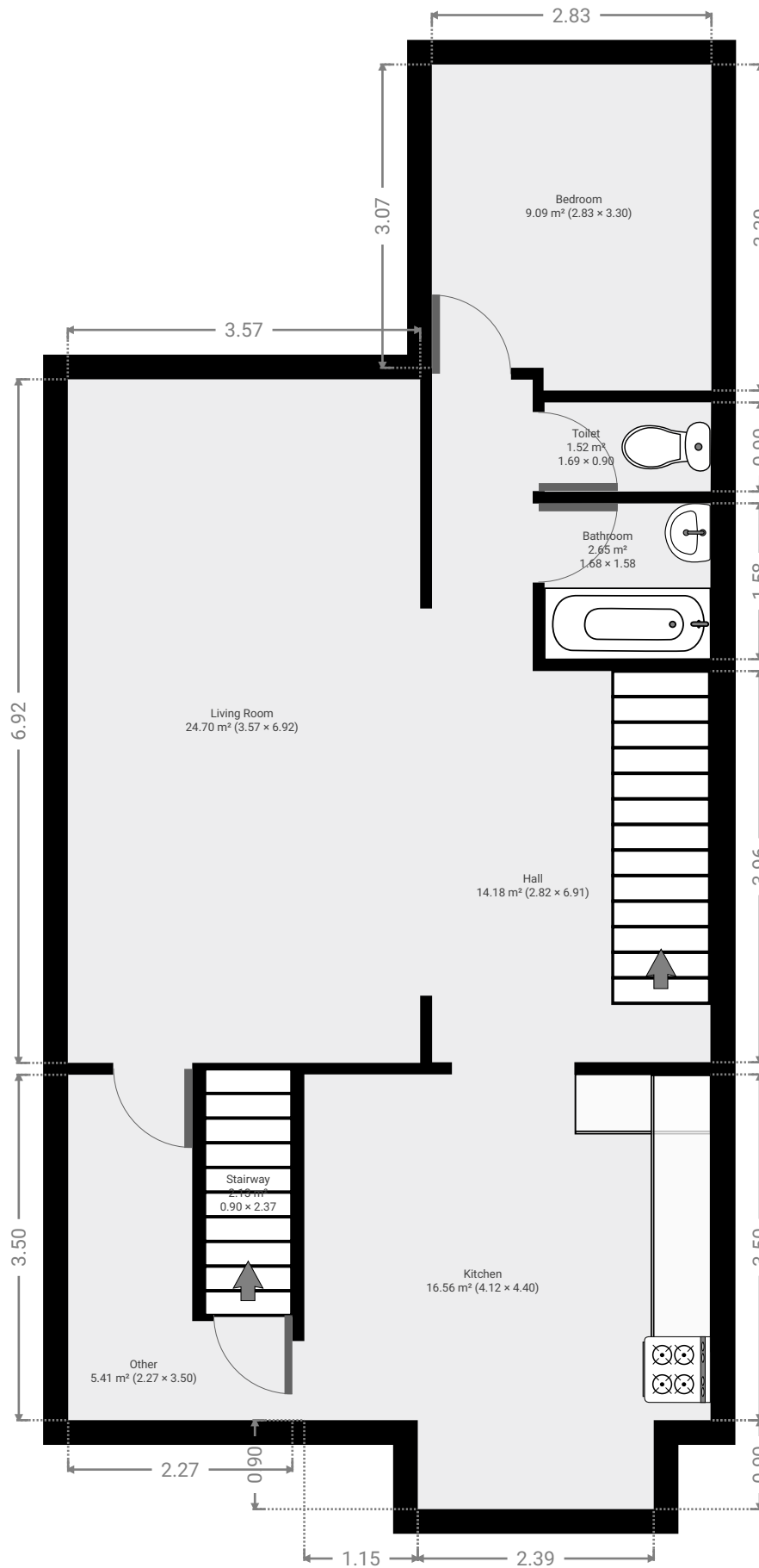

FLOORS: 1

▼ **Bathroom**
1st Floor

WIDTH: 1.58 m • LENGTH: 1.68 m
AREA: 2.65 m² • PERIMETER: 6.52 m

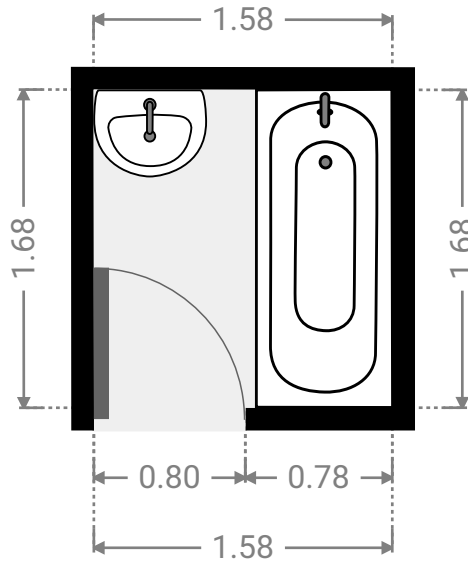
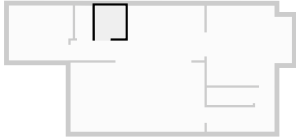

▼ **Bedroom**
1st Floor

WIDTH: 3.30 m • LENGTH: 2.83 m
AREA: 9.09 m² • PERIMETER: 12.26 m

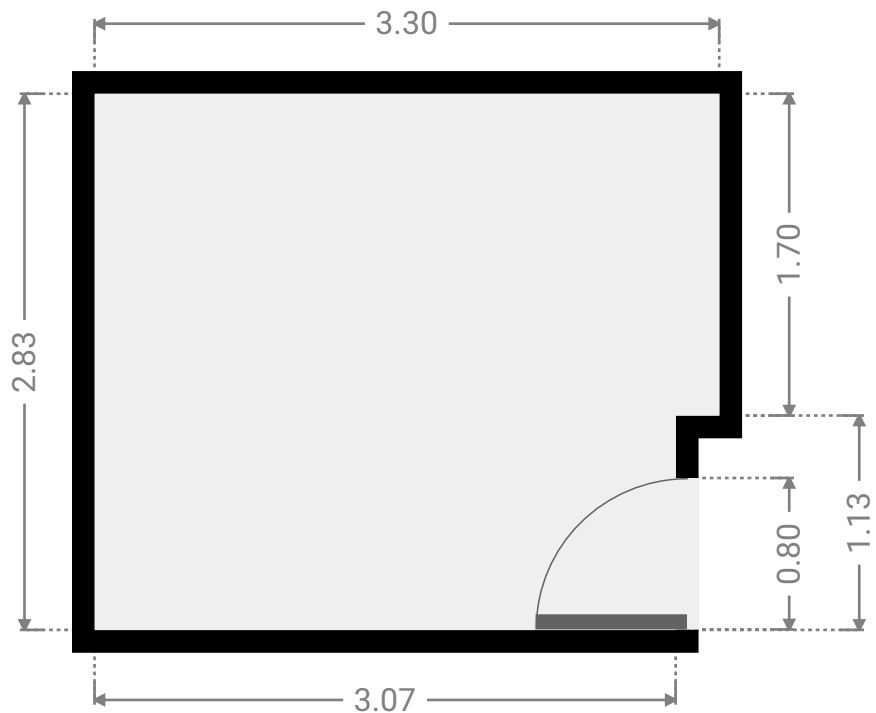
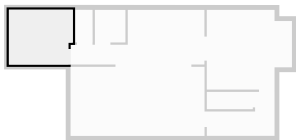

FLOORS: 1

▼ Hall
1st Floor

WIDTH: 6.91 m • LENGTH: 2.82 m
AREA: 14.18 m² • PERIMETER: 19.46 m

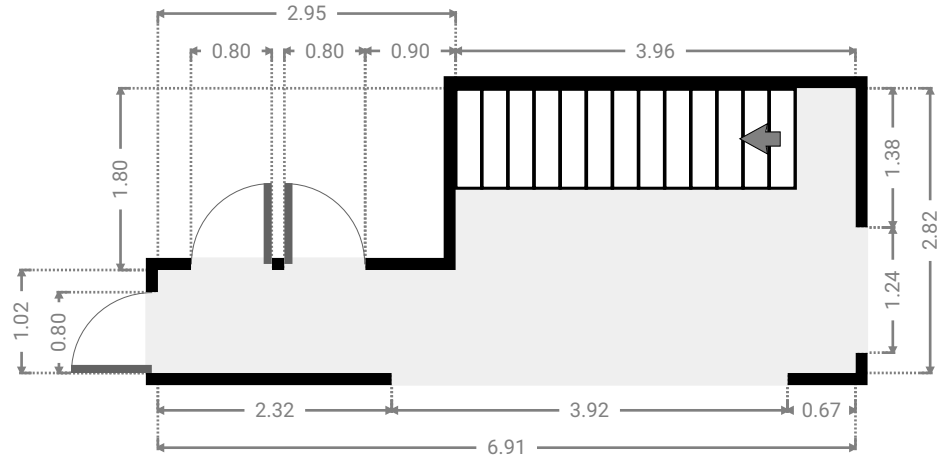
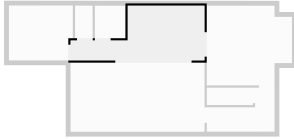

▼ Kitchen
1st Floor

WIDTH: 4.40 m • LENGTH: 4.12 m
AREA: 16.56 m² • PERIMETER: 17.03 m

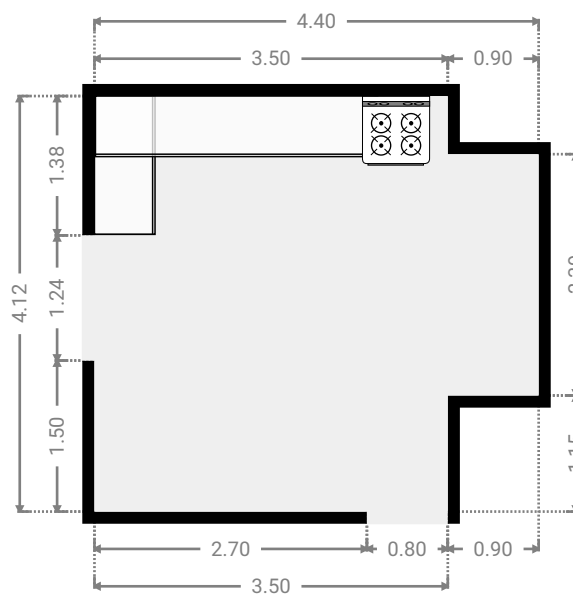
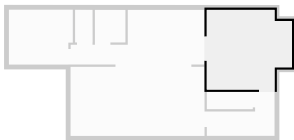

FLOORS: 1

▼ **Living Room**
1st Floor

WIDTH: 6.92 m • LENGTH: 3.57 m
AREA: 24.70 m² • PERIMETER: 20.98 m

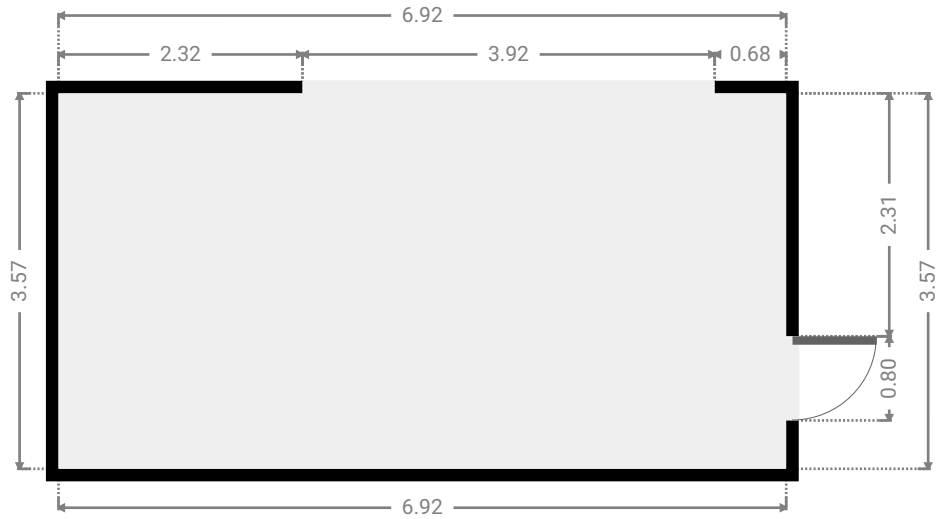
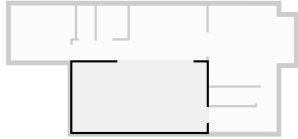

▼ **Other**
1st Floor

WIDTH: 3.50 m • LENGTH: 2.27 m
AREA: 5.41 m² • PERIMETER: 11.54 m

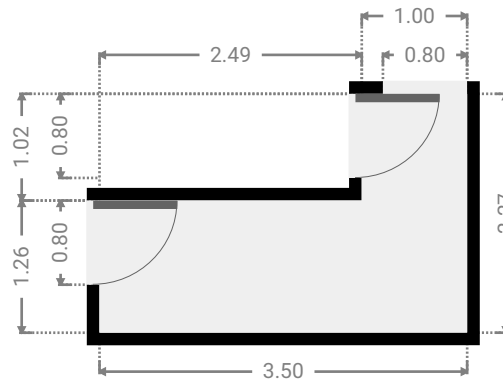
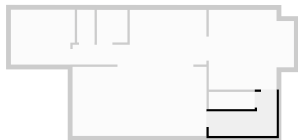

▼ **Stairway**
1st Floor

WIDTH: 2.37 m • LENGTH: 0.90 m
AREA: 2.13 m² • PERIMETER: 6.54 m

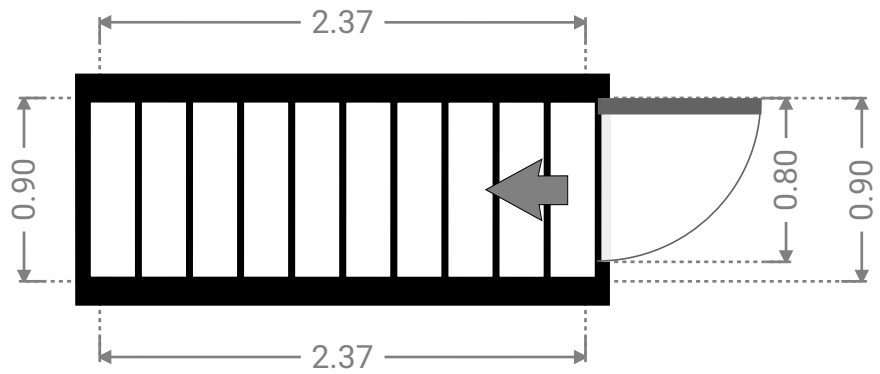
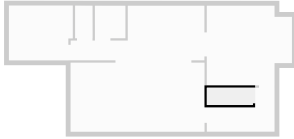

▼ **Toilet**
1st Floor

WIDTH: 0.90 m • LENGTH: 1.69 m
AREA: 1.52 m² • PERIMETER: 5.17 m

