

# 14 Cunningham Street

Created on  
2021-03-09

Floors  
1

▼ Ground Floor

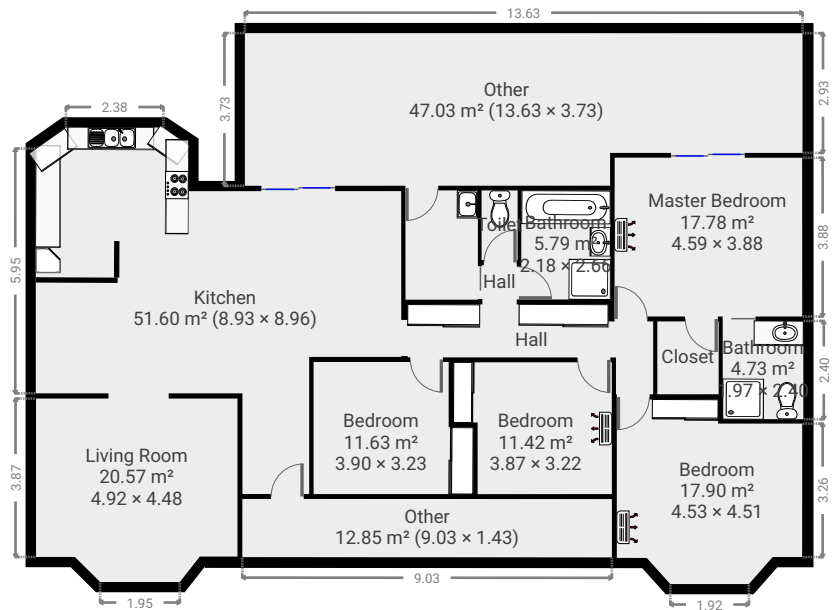
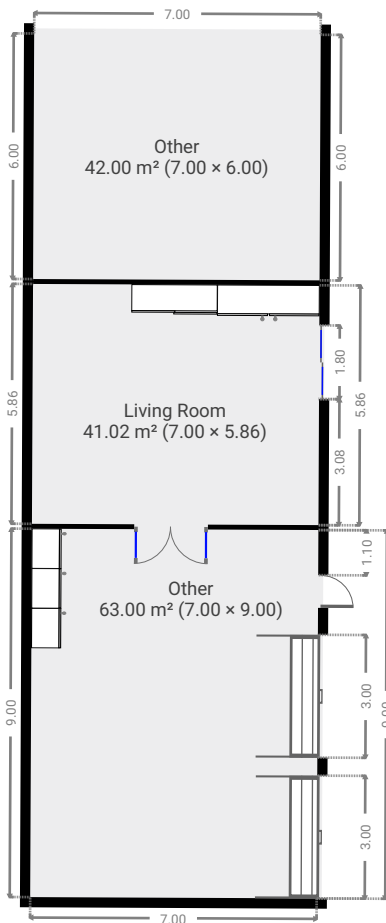
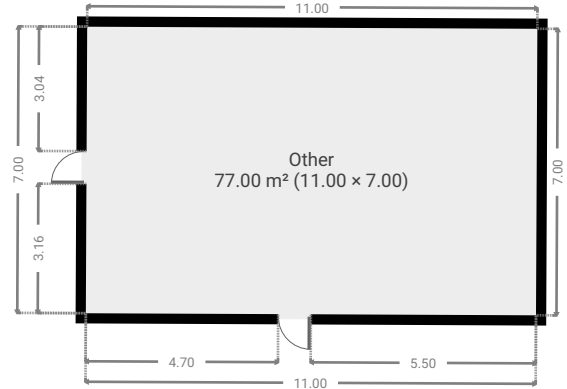
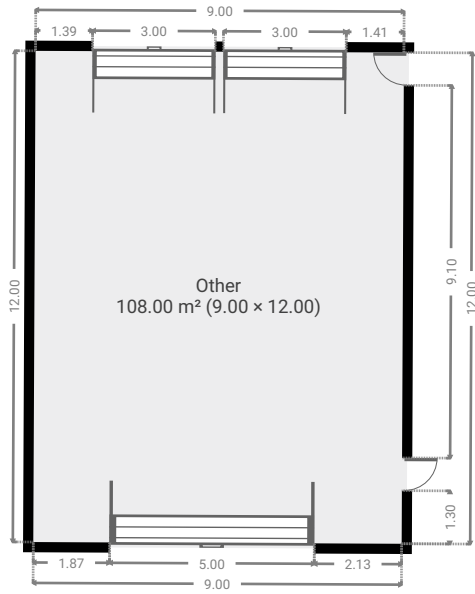

▼ **Toilet**  
Ground Floor

WIDTH: 0.88 m • LENGTH: 1.70 m  
AREA: 1.50 m<sup>2</sup> • PERIMETER: 5.16 m

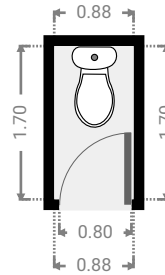
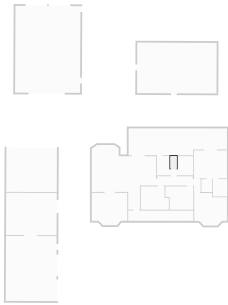

▼ **Other**  
Ground Floor

WIDTH: 9.03 m • LENGTH: 1.43 m  
AREA: 12.85 m<sup>2</sup> • PERIMETER: 20.90 m

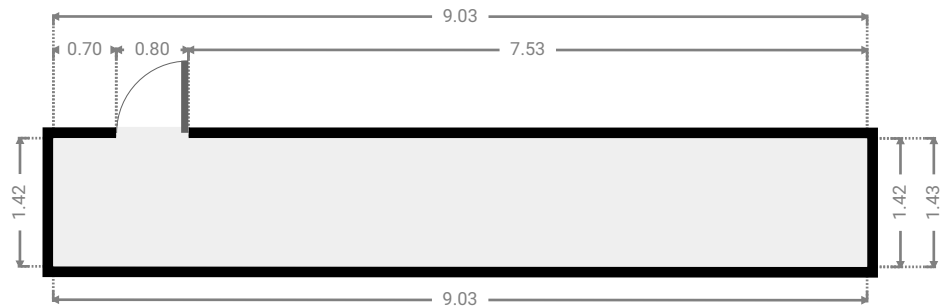

## ▼ Other Ground Floor

WIDTH: 13.63 m • LENGTH: 3.73 m  
AREA: 47.03 m<sup>2</sup> • PERIMETER: 34.71 m

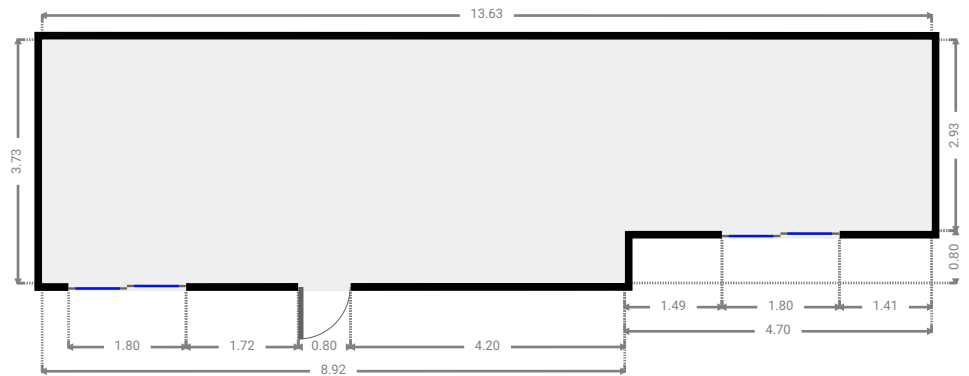
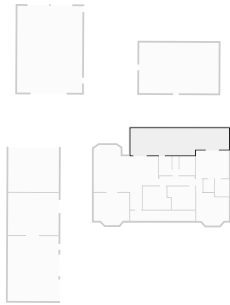

## ▼ Bedroom Ground Floor

WIDTH: 4.53 m • LENGTH: 4.51 m  
AREA: 17.90 m<sup>2</sup> • PERIMETER: 17.36 m

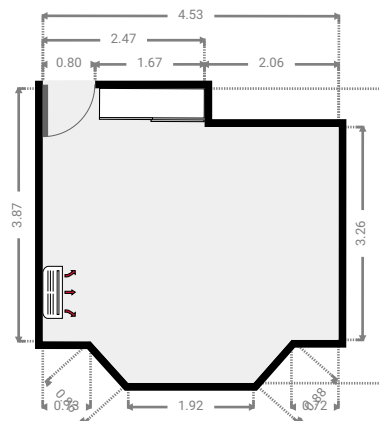
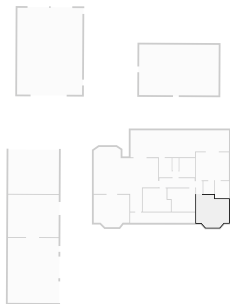

▼ **Bathroom**  
Ground Floor

WIDTH: 1.97 m • LENGTH: 2.40 m  
AREA: 4.73 m<sup>2</sup> • PERIMETER: 8.74 m

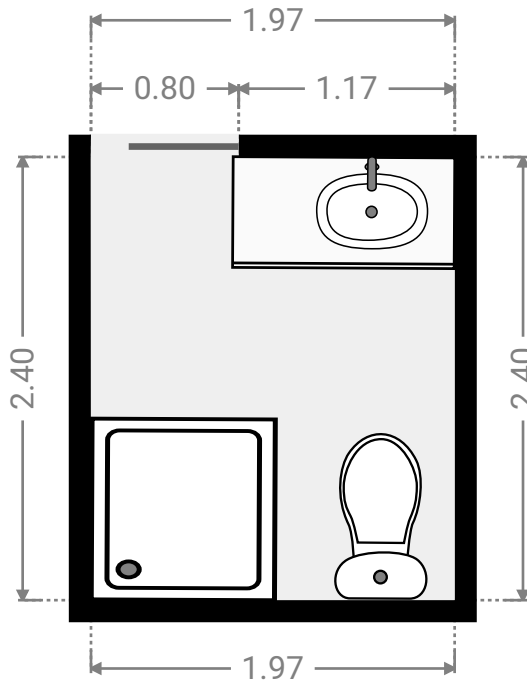
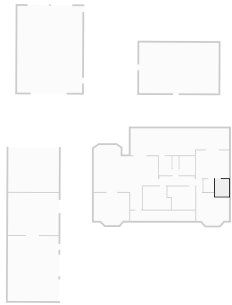

▼ **Closet**  
Ground Floor

WIDTH: 1.50 m • LENGTH: 1.78 m  
AREA: 2.67 m<sup>2</sup> • PERIMETER: 6.56 m

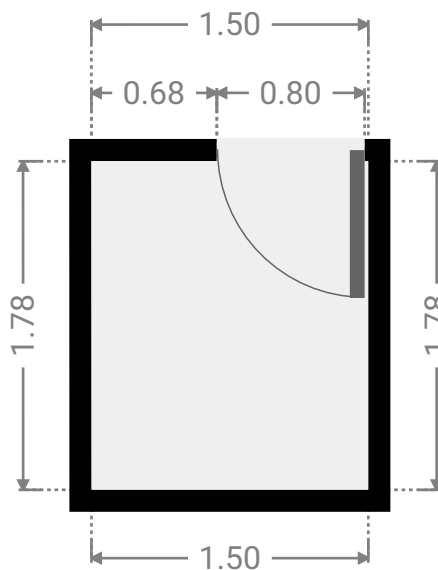

▼ Master Bedroom  
Ground Floor

WIDTH: 4.59 m • LENGTH: 3.88 m  
AREA: 17.78 m<sup>2</sup> • PERIMETER: 16.93 m

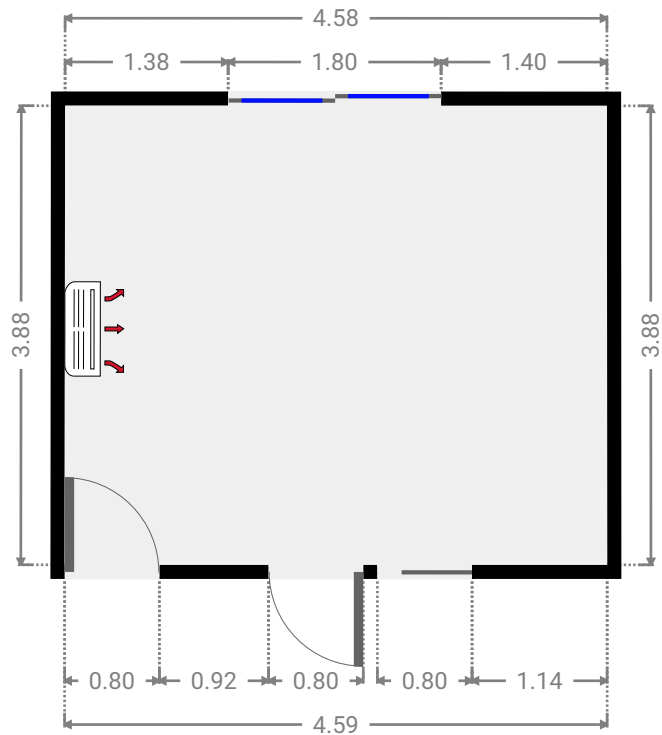

▼ Bedroom  
Ground Floor

WIDTH: 3.87 m • LENGTH: 3.22 m  
AREA: 11.42 m<sup>2</sup> • PERIMETER: 14.17 m

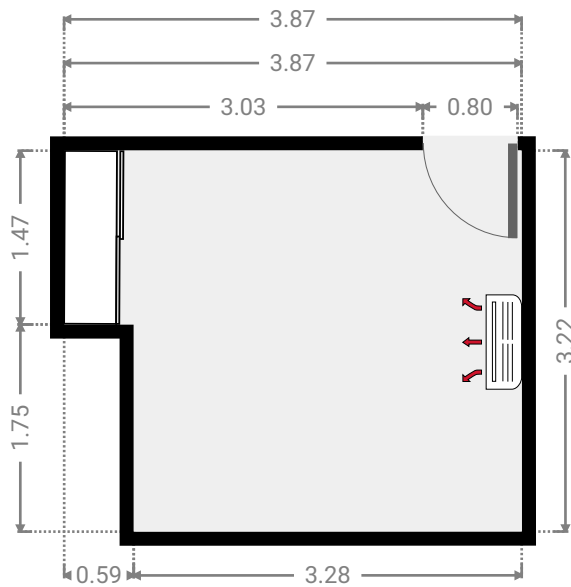

▼ **Bedroom**  
Ground Floor

WIDTH: 3.90 m • LENGTH: 3.23 m  
AREA: 11.63 m<sup>2</sup> • PERIMETER: 14.25 m

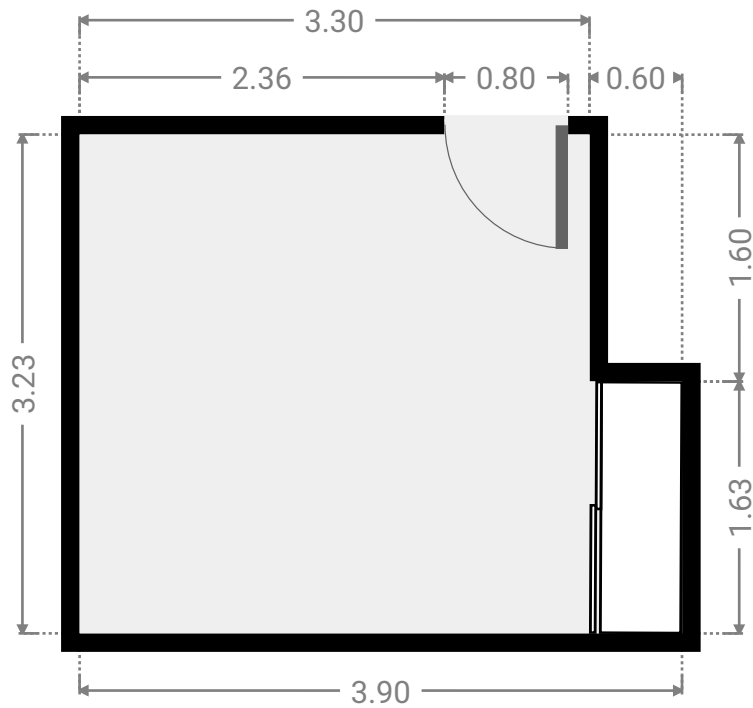

▼ **Hall**  
Ground Floor

WIDTH: 0.84 m • LENGTH: 0.85 m  
AREA: 0.71 m<sup>2</sup> • PERIMETER: 3.38 m

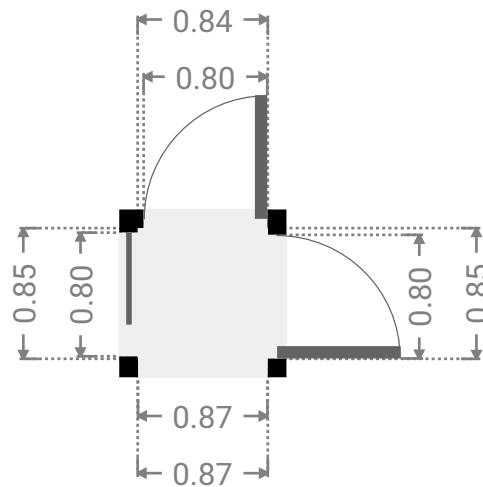

▼ Other  
Ground Floor

WIDTH: 7.00 m • LENGTH: 6.00 m  
AREA: 42.00 m<sup>2</sup> • PERIMETER: 26.00 m

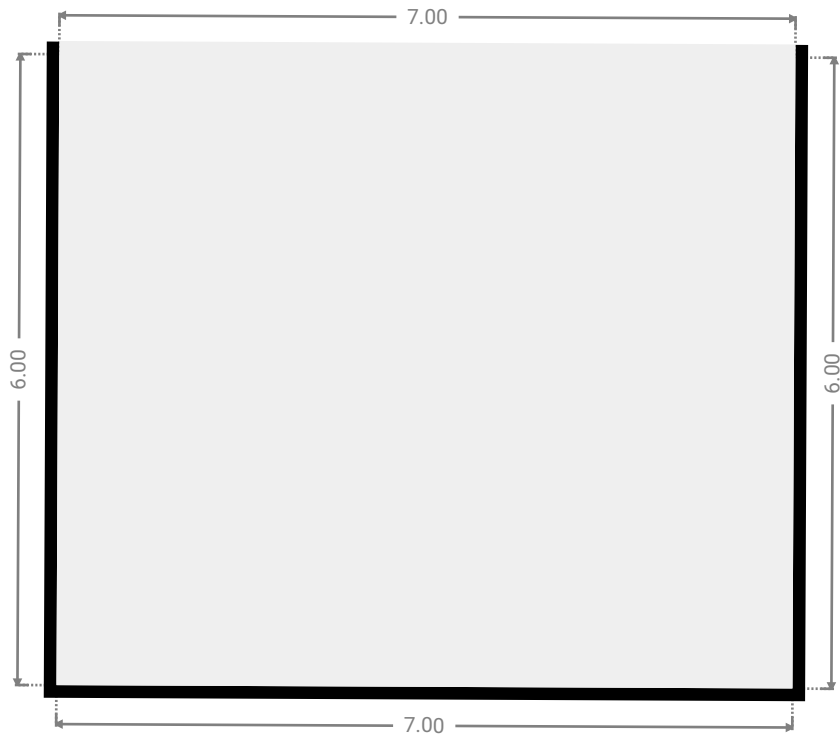

▼ Bathroom  
Ground Floor

WIDTH: 2.18 m • LENGTH: 2.66 m  
AREA: 5.79 m<sup>2</sup> • PERIMETER: 9.68 m

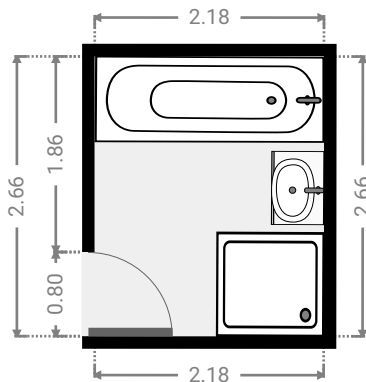



▼ Laundry Room  
Ground Floor

WIDTH: 1.77 m • LENGTH: 2.67 m  
AREA: 4.72 m<sup>2</sup> • PERIMETER: 8.88 m

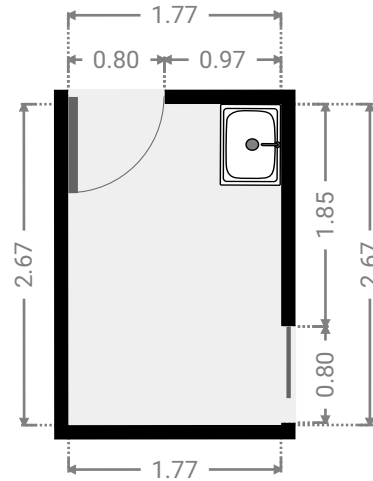

▼ Hall  
Ground Floor

WIDTH: 6.00 m • LENGTH: 2.19 m  
AREA: 8.12 m<sup>2</sup> • PERIMETER: 16.38 m

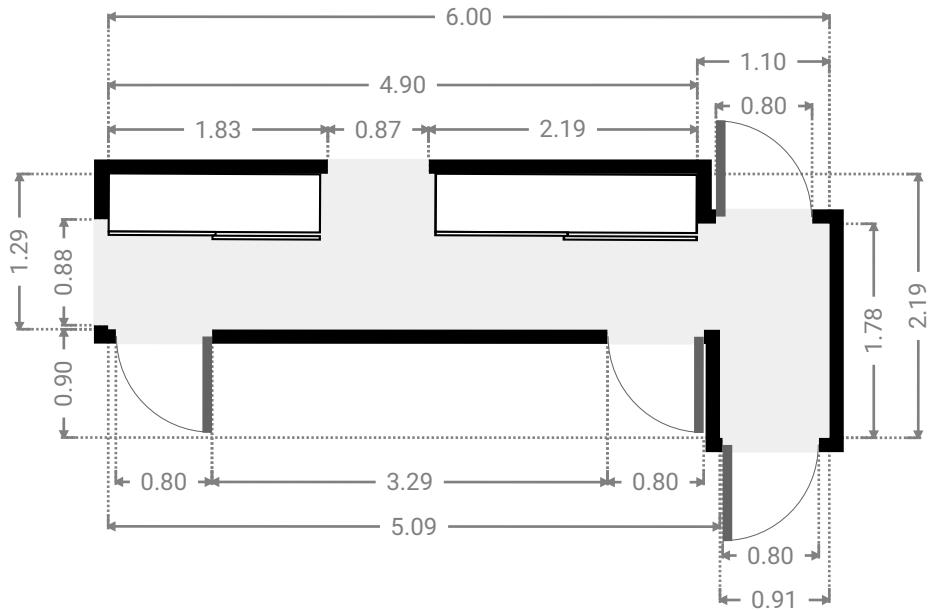
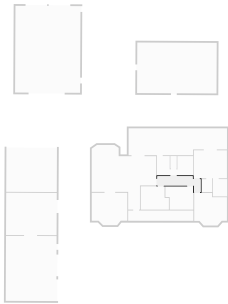

▼ Living Room  
Ground Floor

WIDTH: 4.92 m • LENGTH: 4.48 m  
AREA: 20.57 m<sup>2</sup> • PERIMETER: 18.13 m

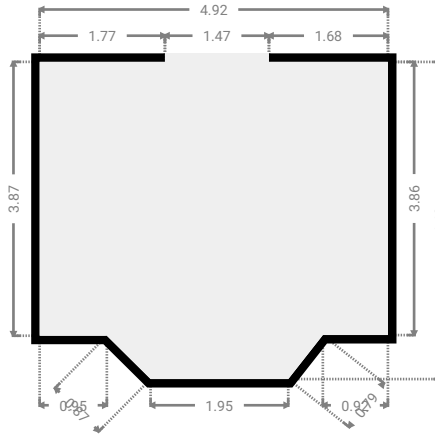

▼ Kitchen  
Ground Floor

WIDTH: 8.93 m • LENGTH: 8.96 m  
AREA: 51.60 m<sup>2</sup> • PERIMETER: 35.13 m

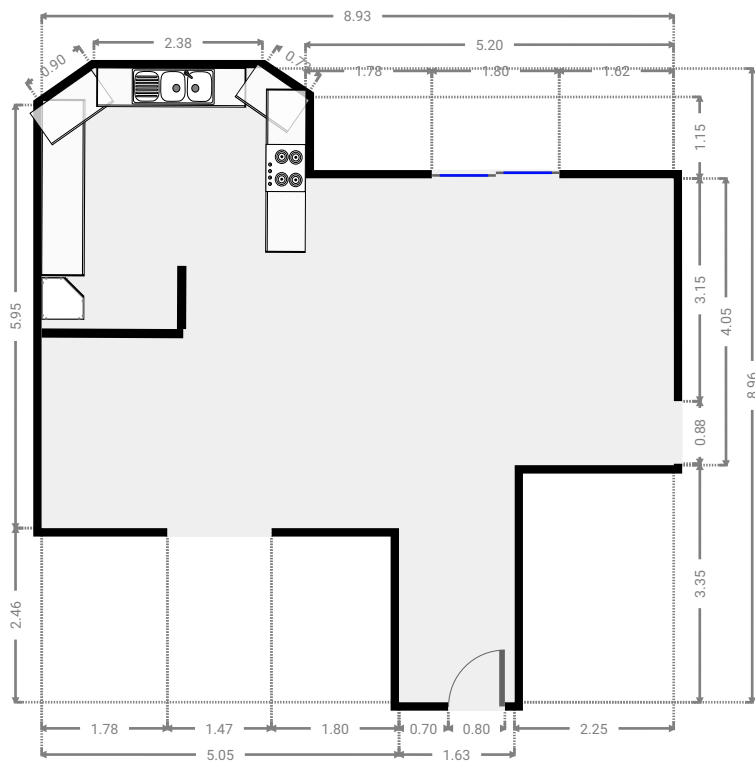
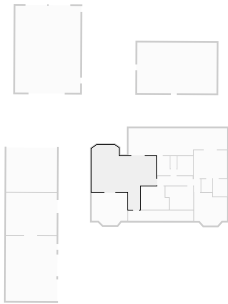

▼ Other  
Ground Floor

WIDTH: 11.00 m • LENGTH: 7.00 m  
AREA: 77.00 m<sup>2</sup> • PERIMETER: 36.00 m

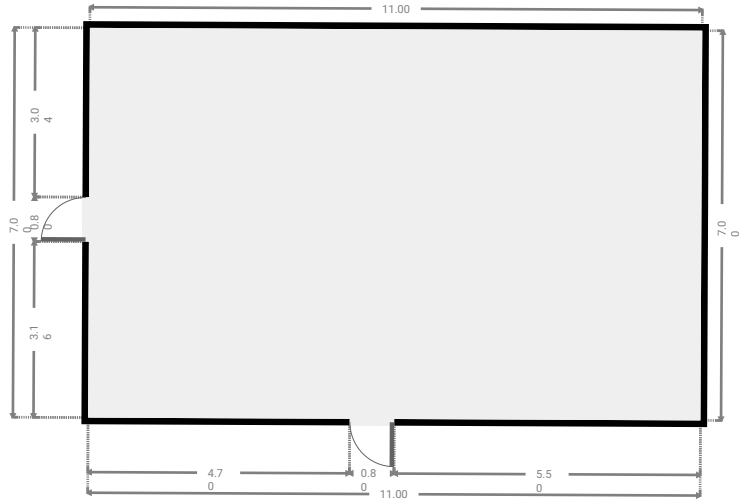
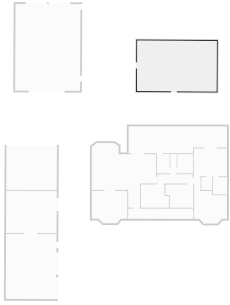

▼ Other  
Ground Floor

WIDTH: 9.00 m • LENGTH: 12.00 m  
AREA: 108.00 m<sup>2</sup> • PERIMETER: 42.00 m

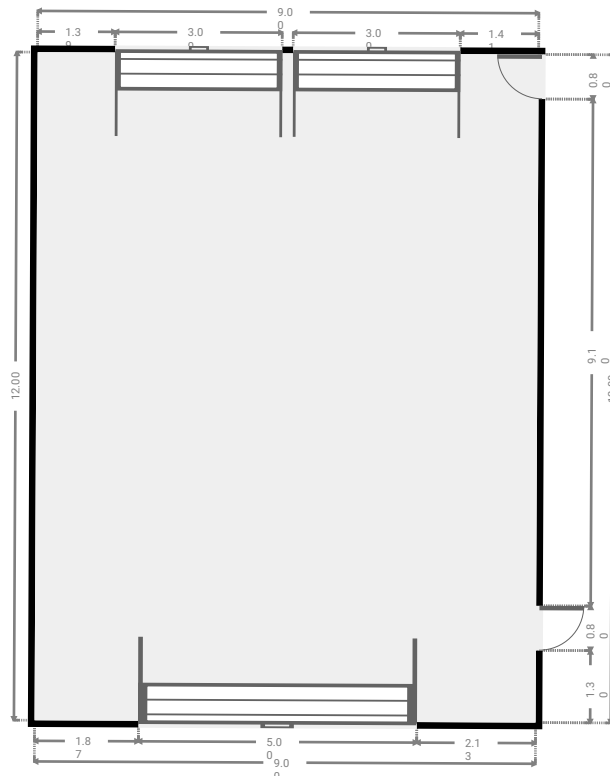
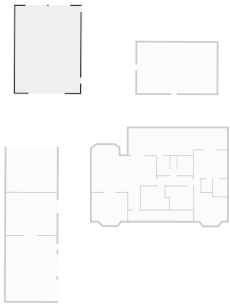

▼ **Other**  
Ground Floor

WIDTH: 7.00 m • LENGTH: 9.00 m  
AREA: 63.00 m<sup>2</sup> • PERIMETER: 32.00 m

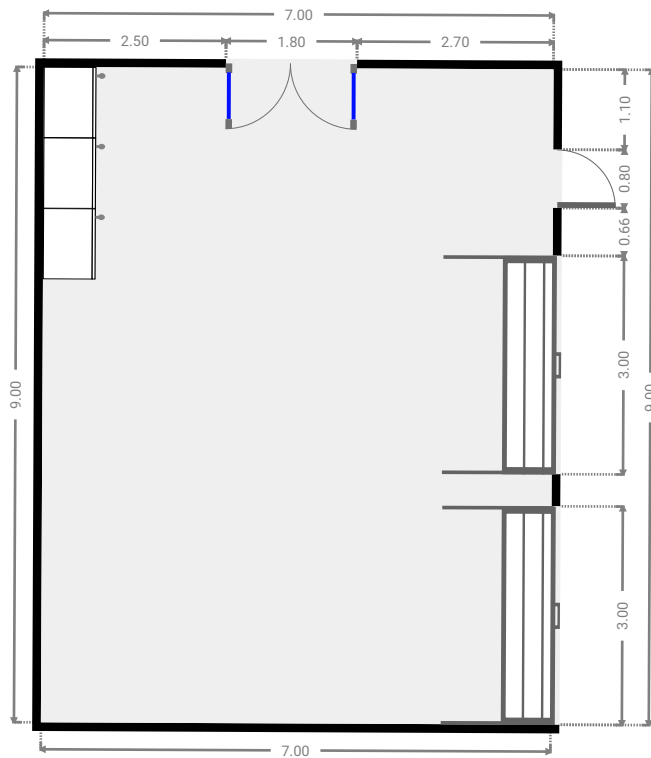
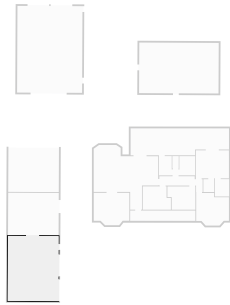

▼ **Living Room**  
Ground Floor

WIDTH: 7.00 m • LENGTH: 5.86 m  
AREA: 41.02 m<sup>2</sup> • PERIMETER: 25.72 m

