

137 Glendale Road

Created on
2021-05-19

Floors
1

▼ Ground Floor

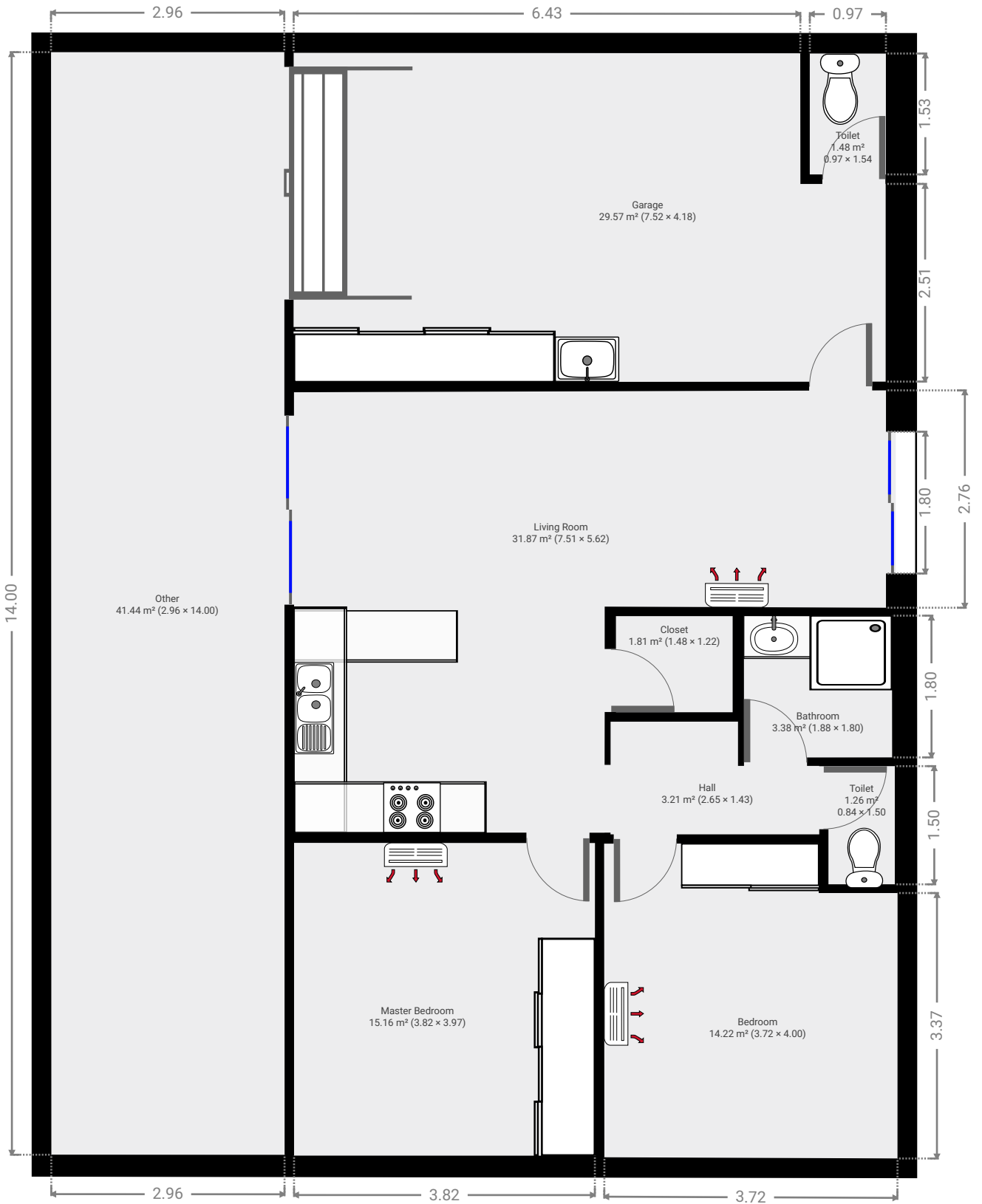

▼ Living Room
Ground Floor

WIDTH: 5.62 m • LENGTH: 7.51 m
AREA: 31.87 m² • PERIMETER: 26.24 m

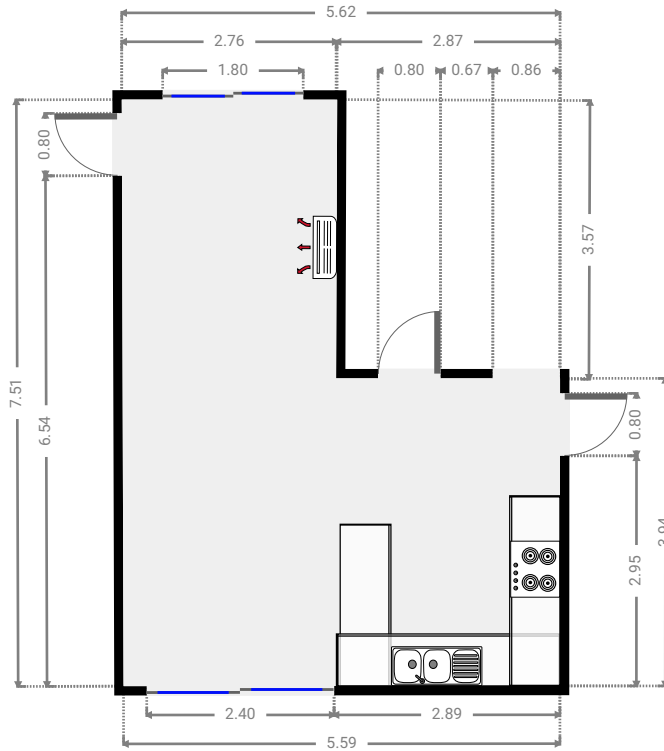
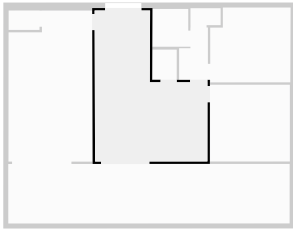

▼ Master Bedroom
Ground Floor

WIDTH: 3.97 m • LENGTH: 3.82 m
AREA: 15.16 m² • PERIMETER: 15.58 m

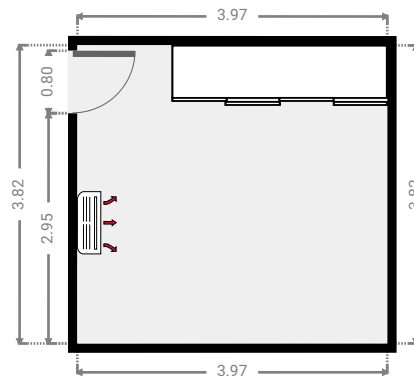
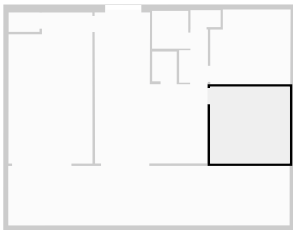

▼ **Garage**
Ground Floor

WIDTH: 4.18 m • LENGTH: 7.52 m
AREA: 29.57 m² • PERIMETER: 23.38 m

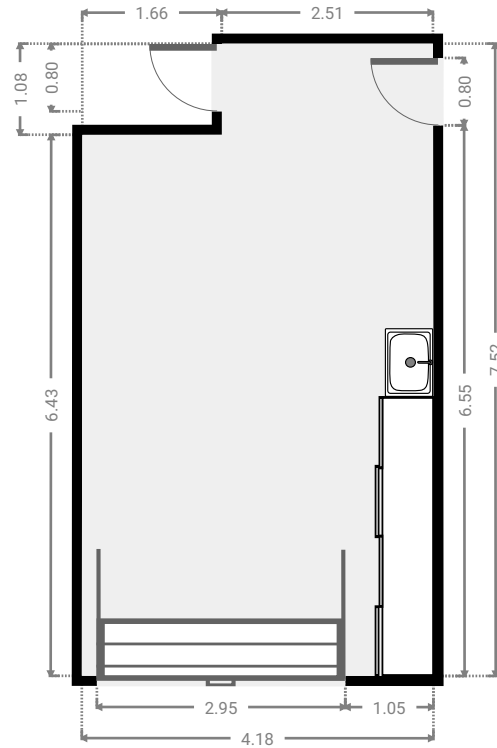
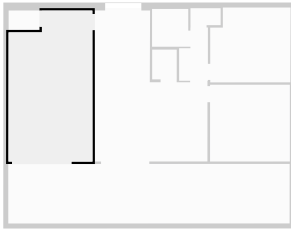

▼ **Toilet**
Ground Floor

WIDTH: 1.54 m • LENGTH: 0.97 m
AREA: 1.48 m² • PERIMETER: 5.00 m

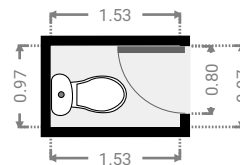
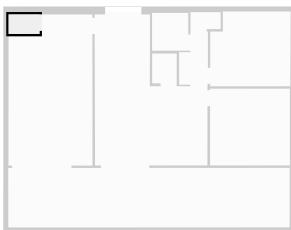

▼ **Closet**
Ground Floor

WIDTH: 1.22 m • LENGTH: 1.48 m
AREA: 1.81 m² • PERIMETER: 5.40 m

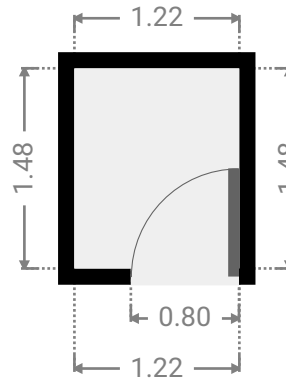
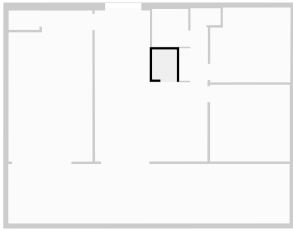

▼ **Hall**
Ground Floor

WIDTH: 1.43 m • LENGTH: 2.65 m
AREA: 3.21 m² • PERIMETER: 8.16 m

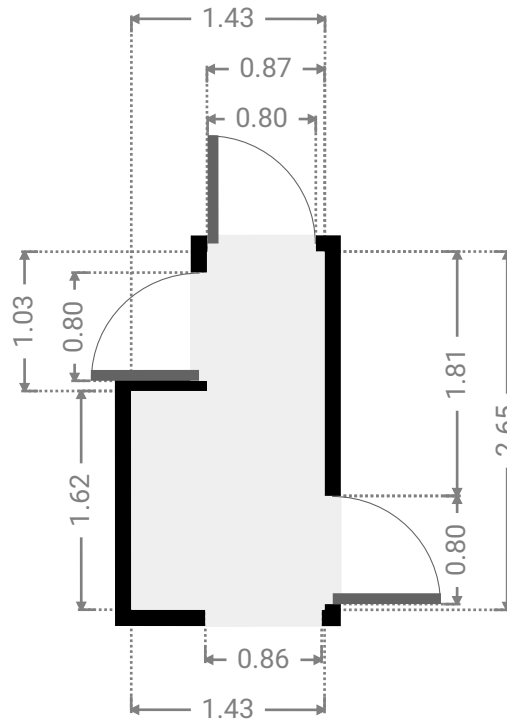
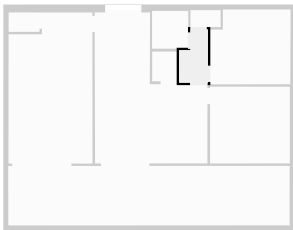

▼ **Bathroom**
Ground Floor

WIDTH: 1.80 m • LENGTH: 1.88 m
AREA: 3.38 m² • PERIMETER: 7.36 m

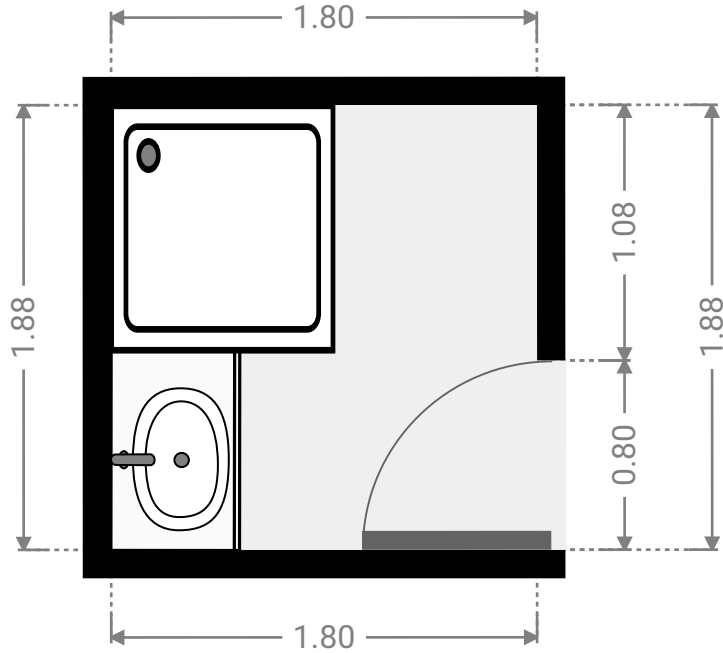
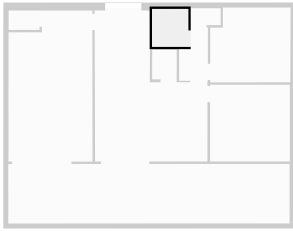

▼ **Toilet**
Ground Floor

WIDTH: 1.50 m • LENGTH: 0.84 m
AREA: 1.26 m² • PERIMETER: 4.68 m

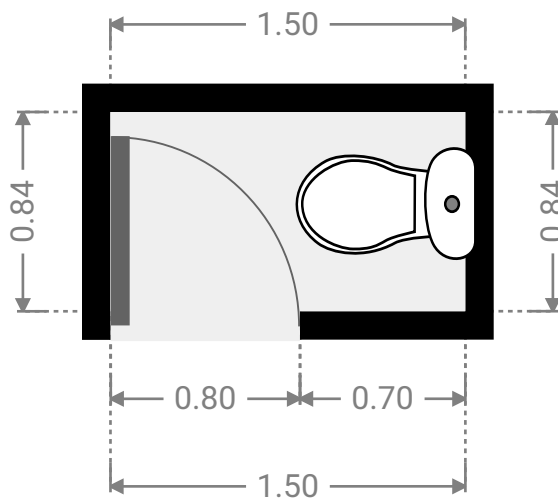
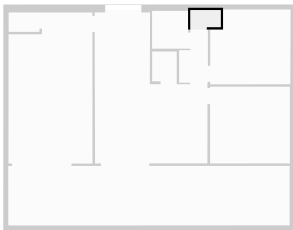

▼ **Bedroom**
Ground Floor

WIDTH: 4.00 m • LENGTH: 3.72 m
AREA: 14.22 m² • PERIMETER: 15.42 m

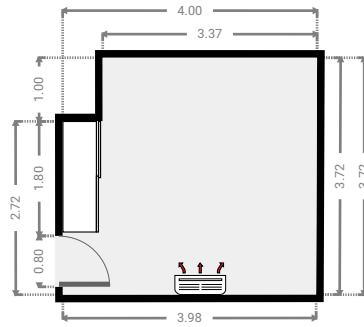
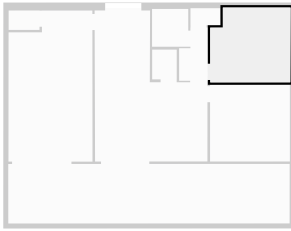

▼ **Other**
Ground Floor

WIDTH: 14.00 m • LENGTH: 2.96 m
AREA: 41.44 m² • PERIMETER: 33.92 m

