

# 132 Wooster Street

**SUBMITTED BY**

Ray White Rockhampton Casey  
stockers@cqoz.com

---

**CREATED ON**

2022-06-15

---

**Floors**

2

---

▼ Ground Floor

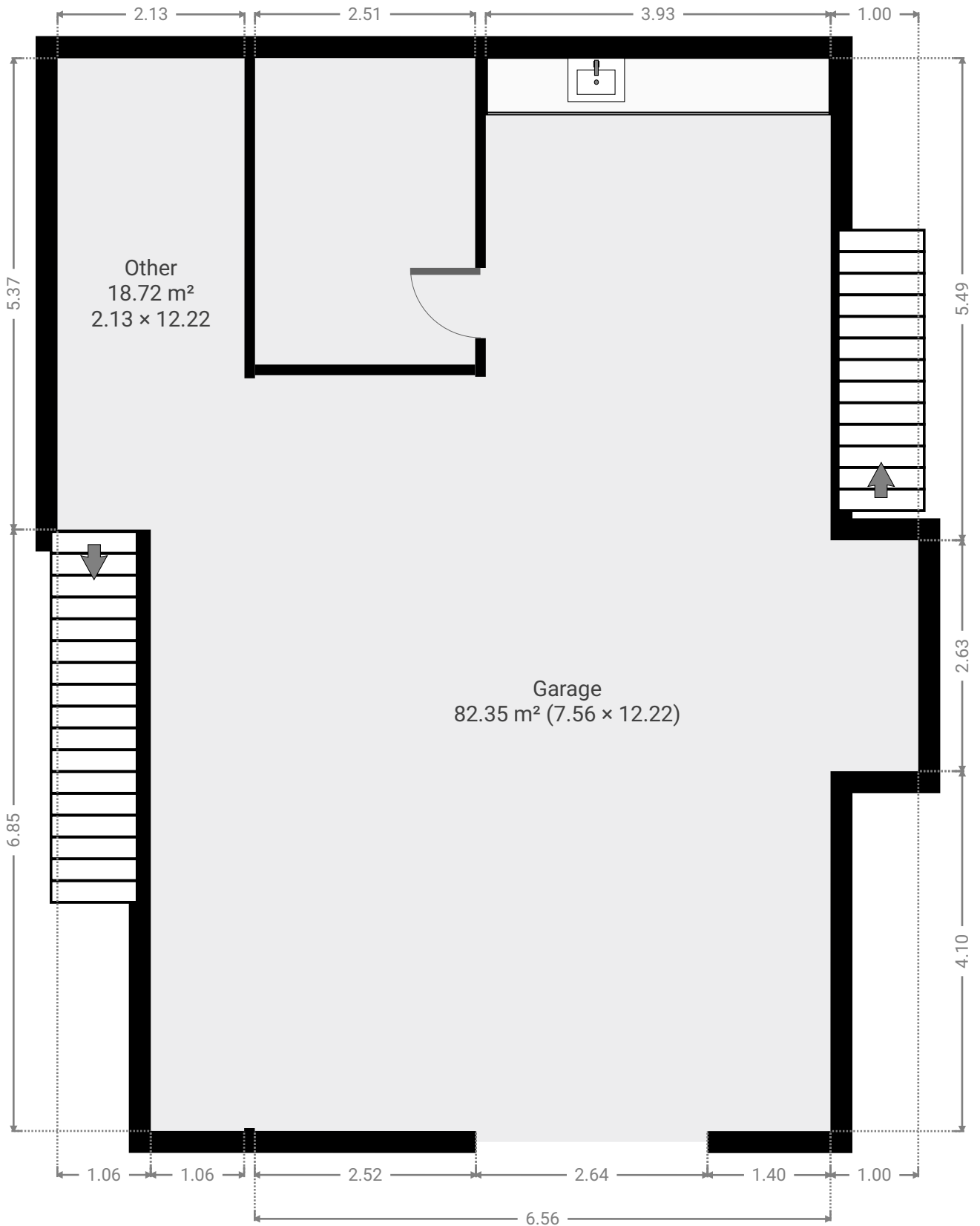

▼ **Garage**  
Ground Floor

WIDTH: 12.22 m • LENGTH: 7.56 m  
AREA: 82.35 m<sup>2</sup> • PERIMETER: 46.82 m

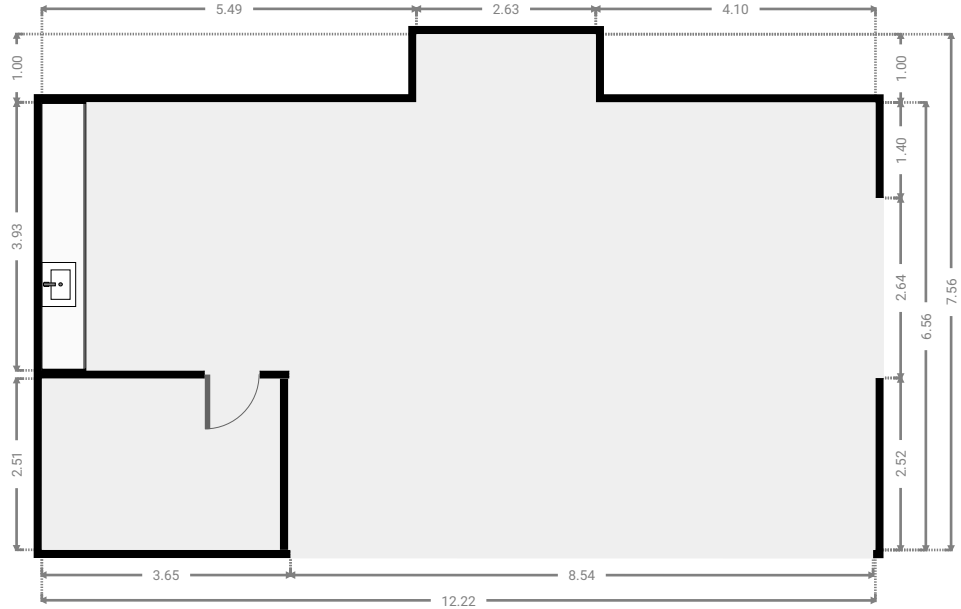
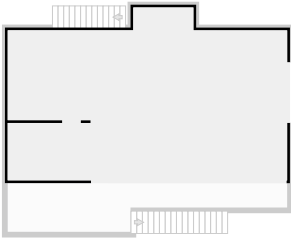

▼ **Other**  
Ground Floor

WIDTH: 12.22 m • LENGTH: 2.13 m  
AREA: 18.72 m<sup>2</sup> • PERIMETER: 28.69 m

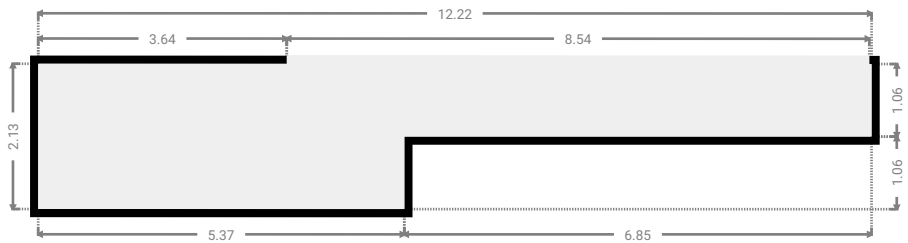
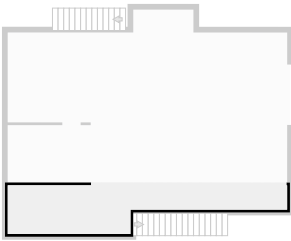

▼ 1st Floor



▼ **Bathroom**  
1st Floor

WIDTH: 1.58 m • LENGTH: 2.72 m  
AREA: 4.28 m<sup>2</sup> • PERIMETER: 8.59 m

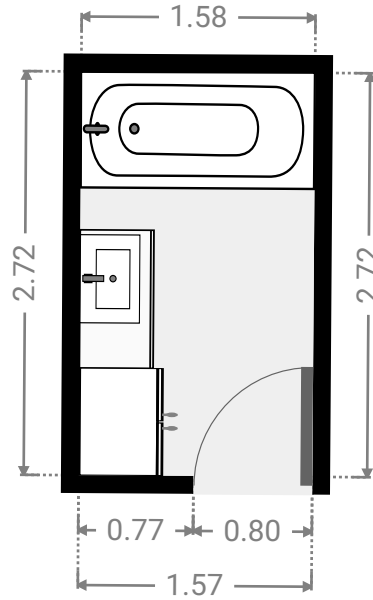
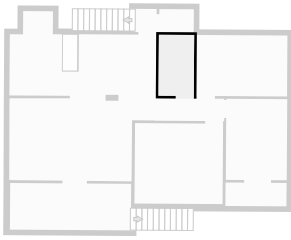

▼ **Bedroom**  
1st Floor

WIDTH: 3.93 m • LENGTH: 3.59 m  
AREA: 14.11 m<sup>2</sup> • PERIMETER: 15.04 m

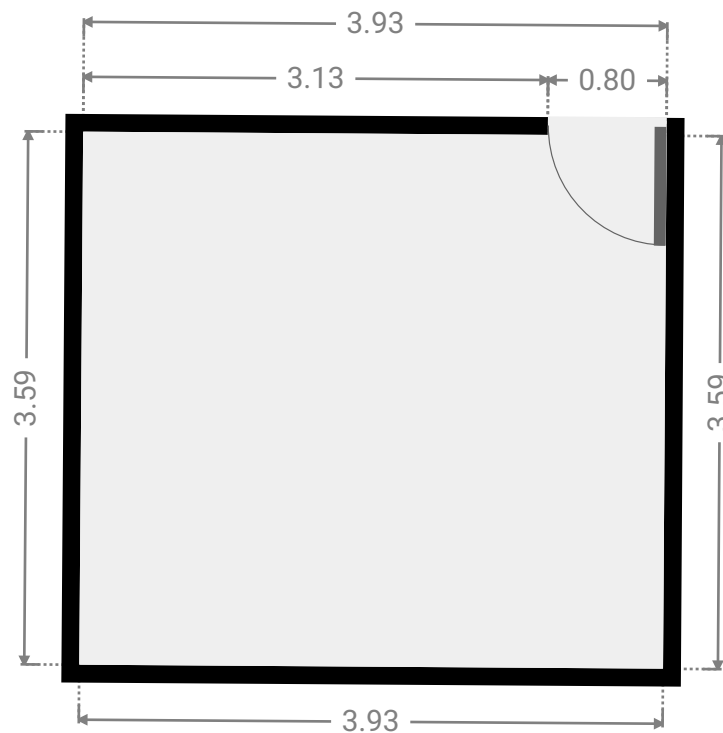
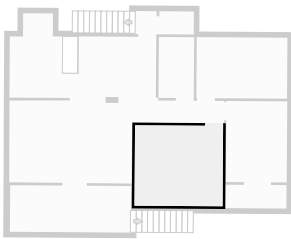

▼ Bedroom  
1st Floor

WIDTH: 2.72 m • LENGTH: 3.62 m  
AREA: 9.85 m<sup>2</sup> • PERIMETER: 12.68 m

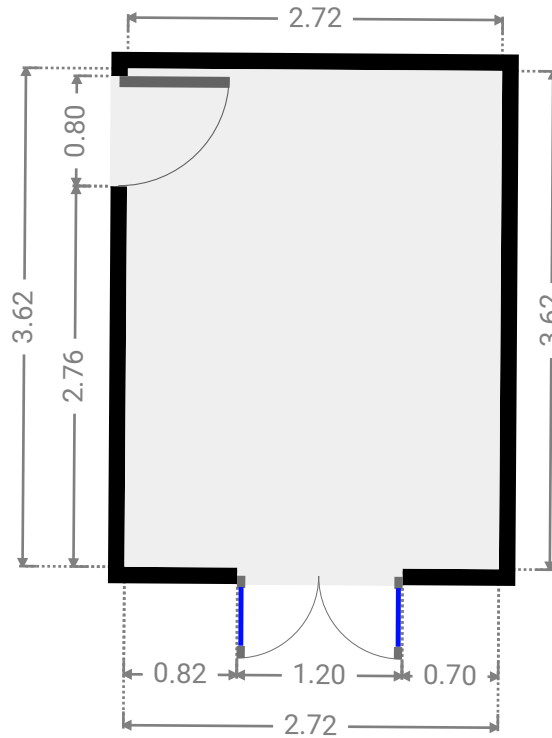
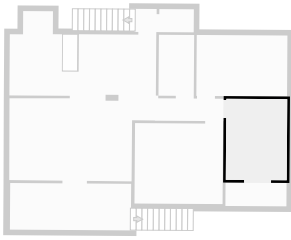

▼ Bedroom  
1st Floor

WIDTH: 4.05 m • LENGTH: 2.72 m  
AREA: 11.02 m<sup>2</sup> • PERIMETER: 13.54 m

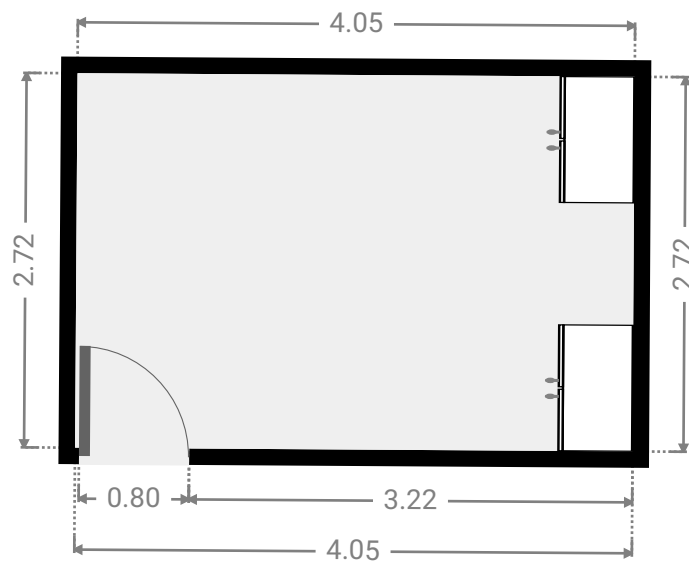
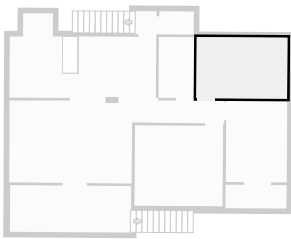

▼ Dining Room  
1st Floor

WIDTH: 3.83 m • LENGTH: 2.73 m  
AREA: 10.45 m<sup>2</sup> • PERIMETER: 13.12 m

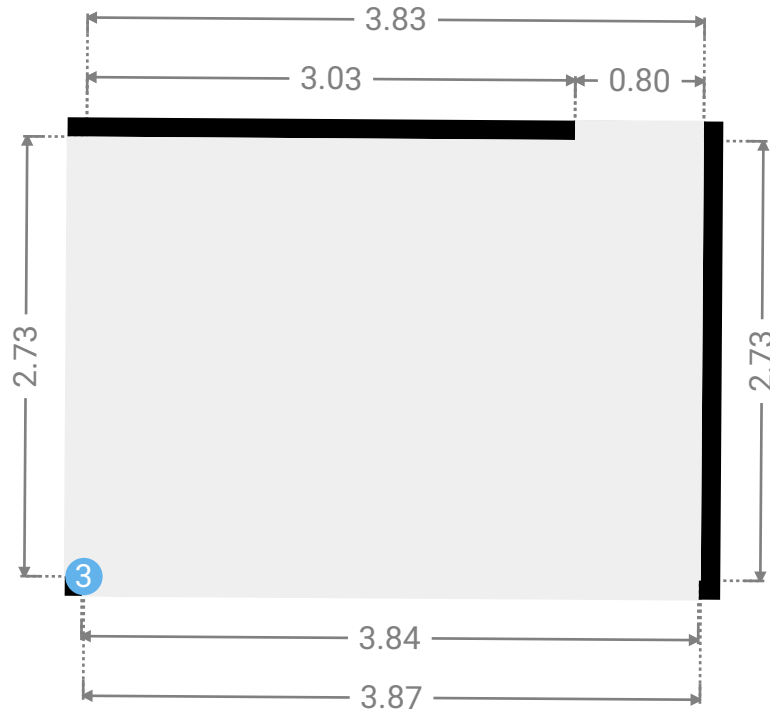
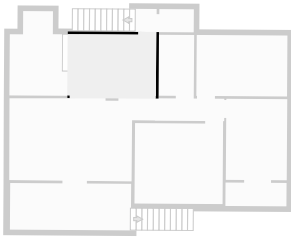

▼ Hall  
1st Floor

WIDTH: 2.97 m • LENGTH: 1.00 m  
AREA: 2.97 m<sup>2</sup> • PERIMETER: 7.94 m

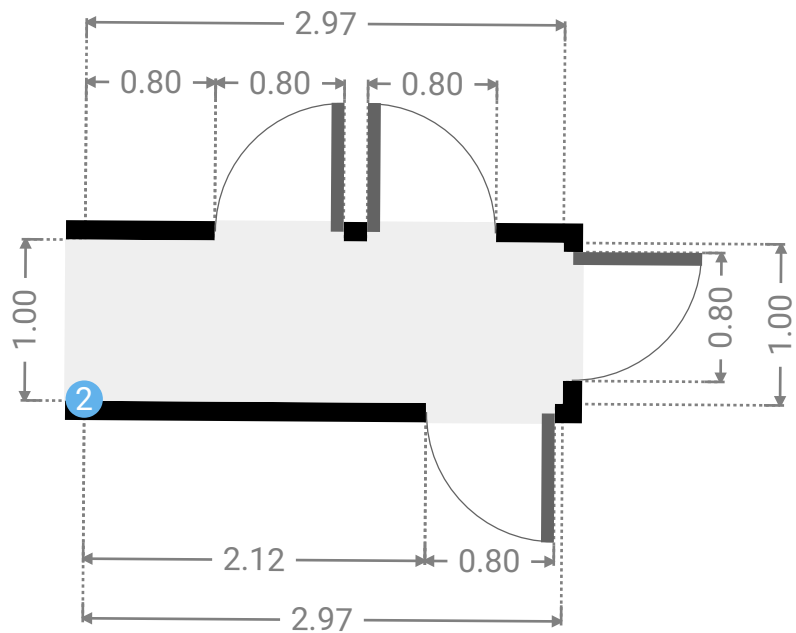
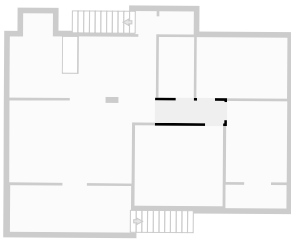

▼ **Hall**  
1st Floor

WIDTH: 0.98 m • LENGTH: 1.03 m  
AREA: 1.01 m<sup>2</sup> • PERIMETER: 4.02 m

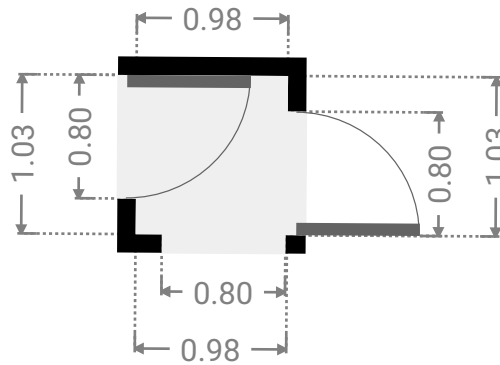
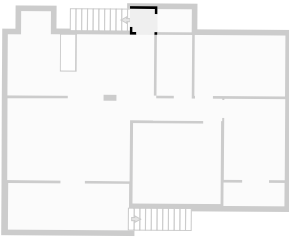

▼ **Kitchen**  
1st Floor

WIDTH: 2.59 m • LENGTH: 3.77 m  
AREA: 8.46 m<sup>2</sup> • PERIMETER: 12.72 m

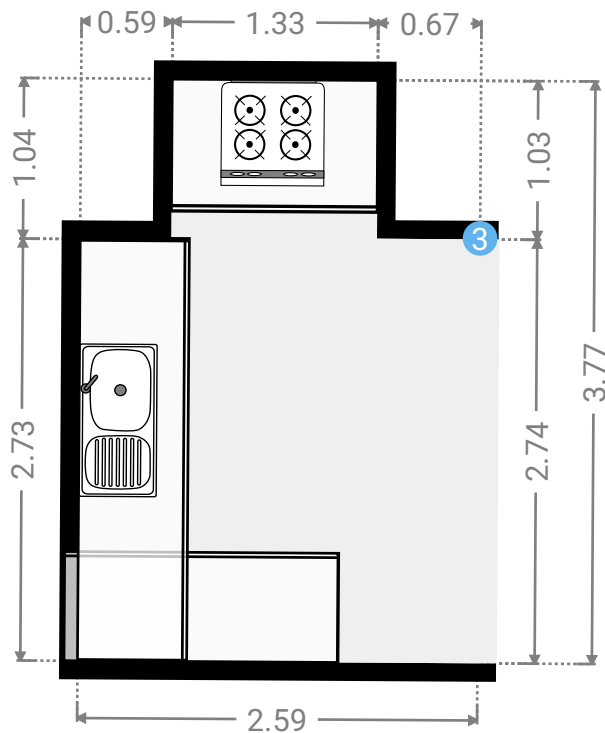



▼ **Kitchen/1st Floor**

---

3 **OPENING**

Height  
0.00 m



▼ **Living Room**  
1st Floor

WIDTH: 5.40 m • LENGTH: 2.08 m  
AREA: 11.23 m<sup>2</sup> • PERIMETER: 14.96 m

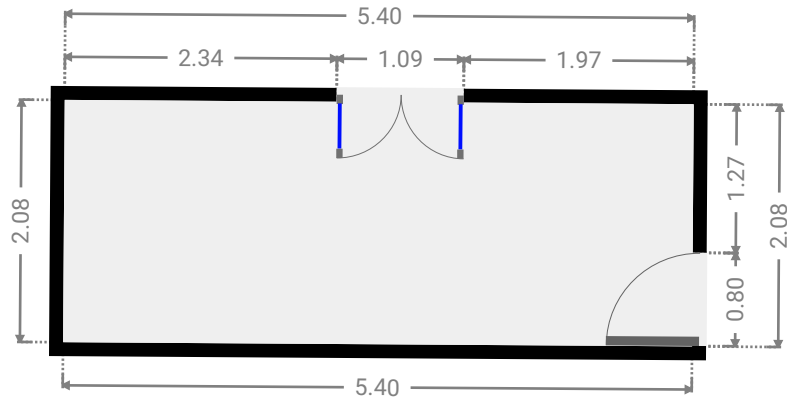
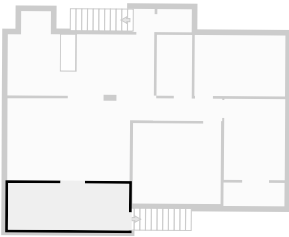

▼ **Living Room**  
1st Floor

WIDTH: 6.53 m • LENGTH: 3.71 m  
AREA: 21.16 m<sup>2</sup> • PERIMETER: 20.39 m

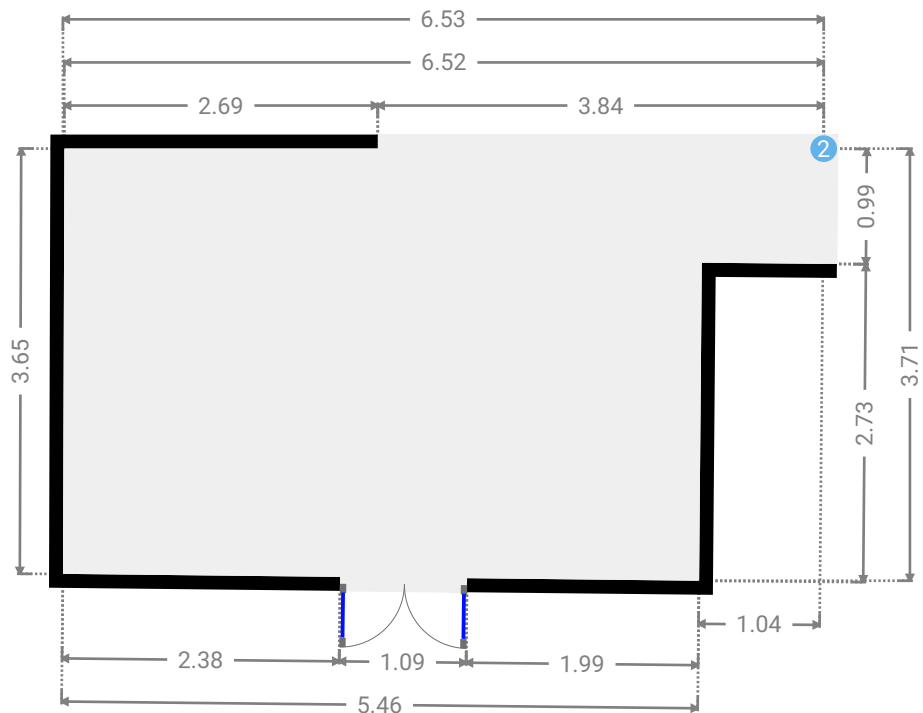
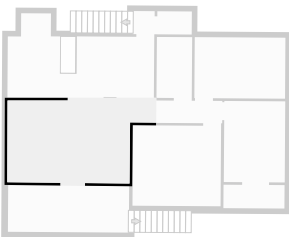

▼ Living Room/1st Floor

2 OPENING

Height  
0.00 m



▼ **Other**  
1st Floor

WIDTH: 2.72 m • LENGTH: 1.05 m  
AREA: 2.85 m<sup>2</sup> • PERIMETER: 7.54 m

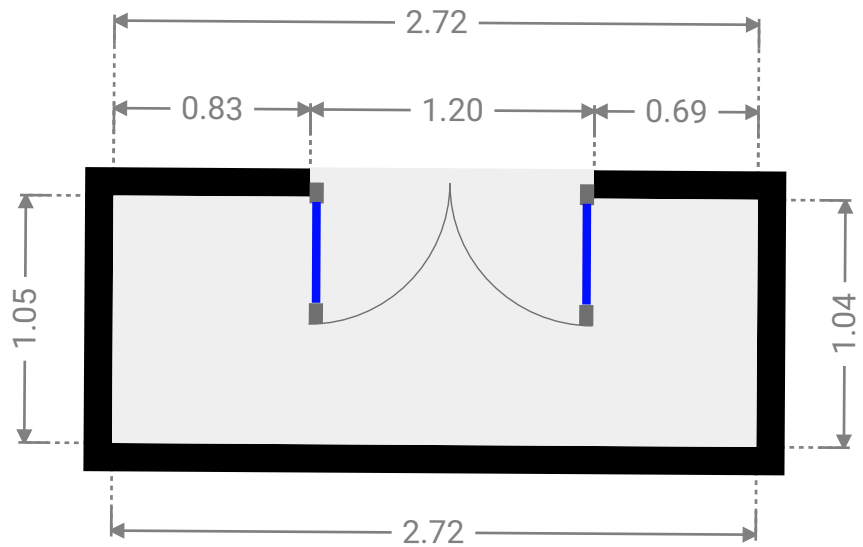
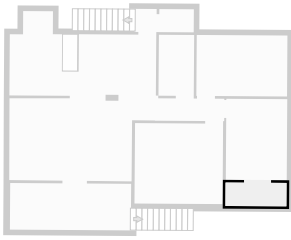

▼ **Toilet**  
1st Floor

WIDTH: 1.54 m • LENGTH: 1.03 m  
AREA: 1.58 m<sup>2</sup> • PERIMETER: 5.14 m

