

# 132 Bremner Street

**SUBMITTED BY**

Ray White Rockhampton Casey stockers@cqoz.com

---

**CREATED ON**

2022-08-22

---

**Floors**

2

---

---

▼ Ground Floor

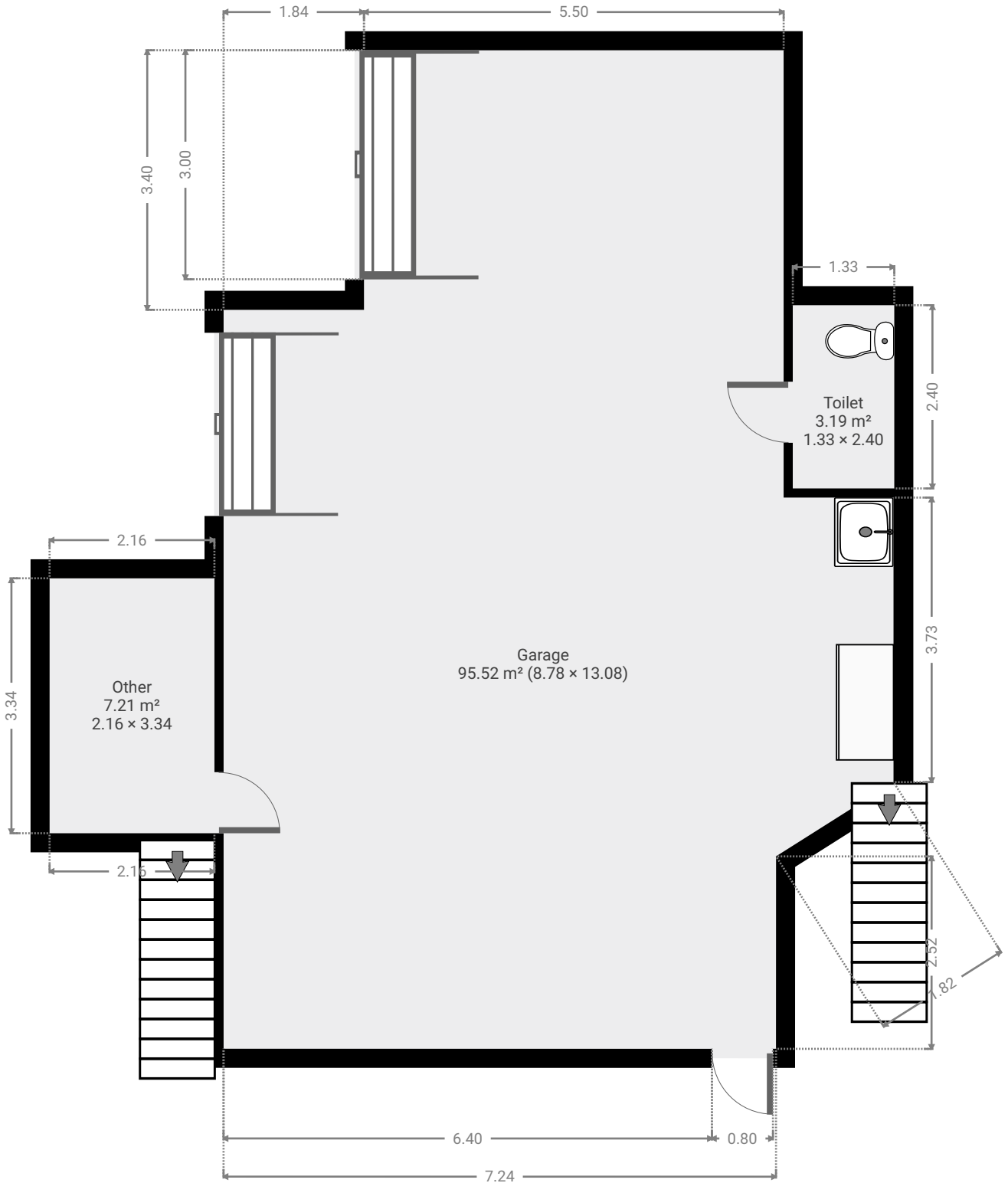

FLOORS: 2

▼ **Garage**  
Ground Floor

WIDTH: 13.08 m • LENGTH: 8.78 m  
AREA: 95.52 m<sup>2</sup> • PERIMETER: 43.03 m

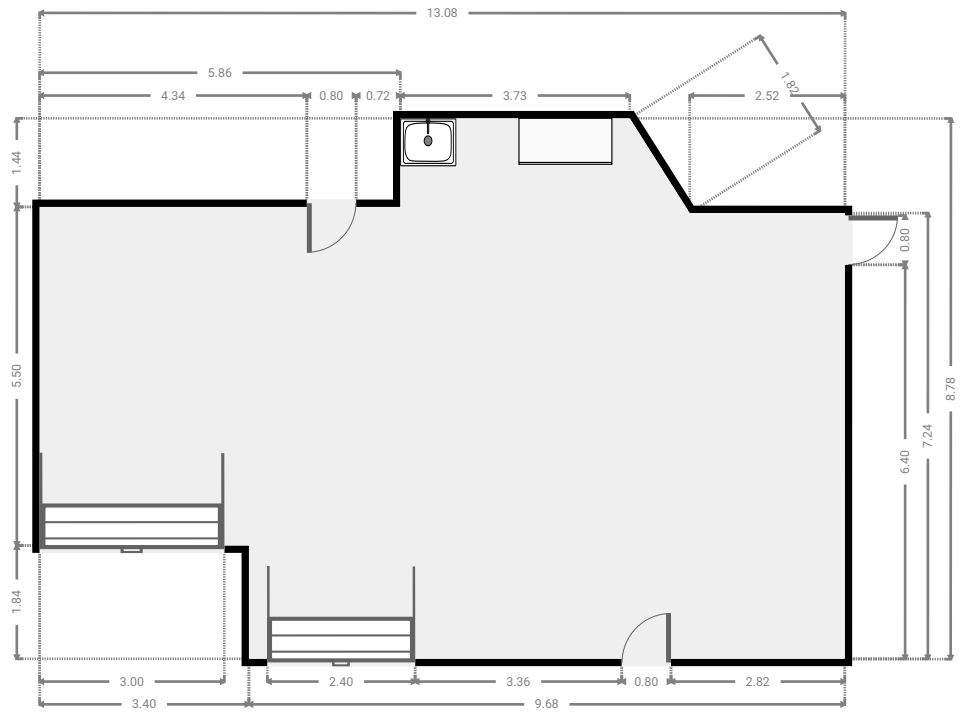
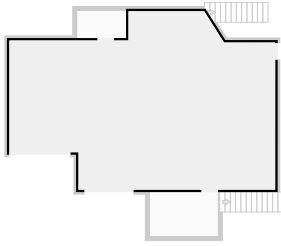

▼ **Other**  
Ground Floor

WIDTH: 3.34 m • LENGTH: 2.16 m  
AREA: 7.21 m<sup>2</sup> • PERIMETER: 11.00 m

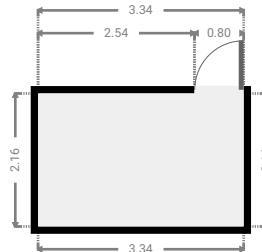
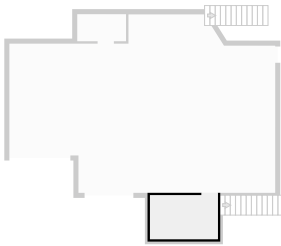

▼ Toilet  
Ground Floor

WIDTH: 2.40 m • LENGTH: 1.33 m  
AREA: 3.19 m<sup>2</sup> • PERIMETER: 7.46 m

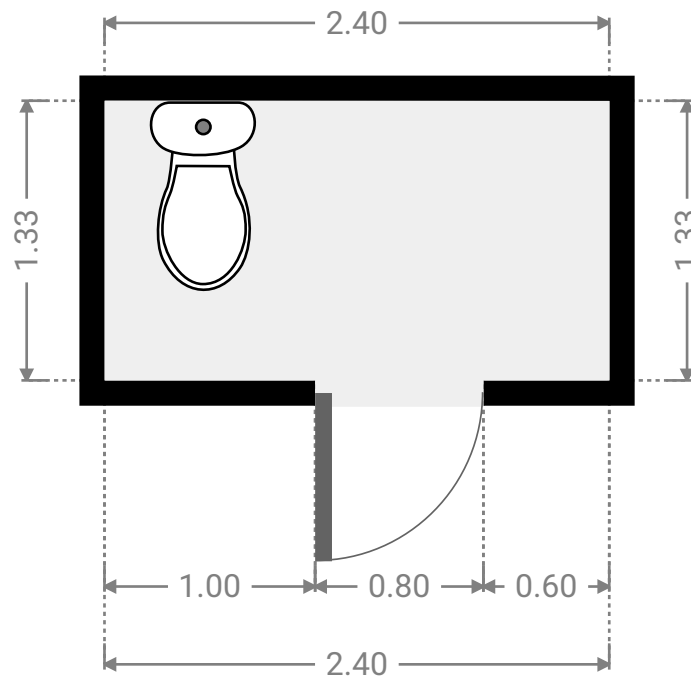
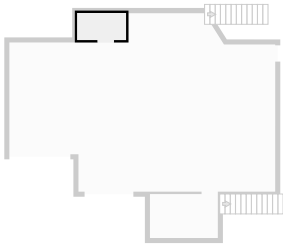

▼ 1st Floor



▼ **Bathroom**  
1st Floor

WIDTH: 2.40 m • LENGTH: 2.70 m  
AREA: 6.48 m<sup>2</sup> • PERIMETER: 10.20 m

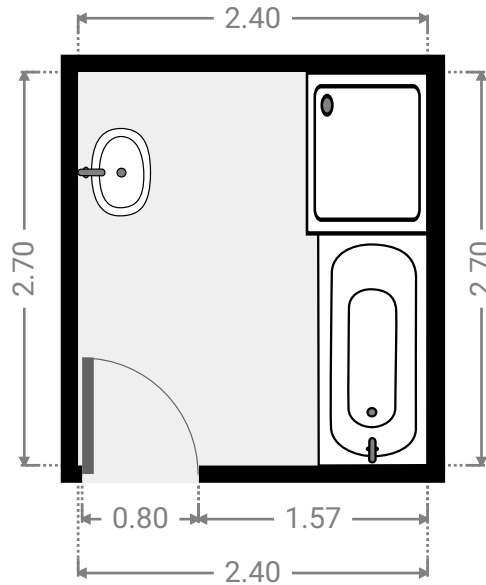
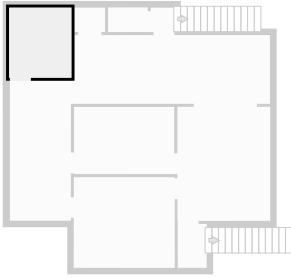

▼ **Bedroom**  
1st Floor

WIDTH: 3.90 m • LENGTH: 3.50 m  
AREA: 13.63 m<sup>2</sup> • PERIMETER: 14.79 m

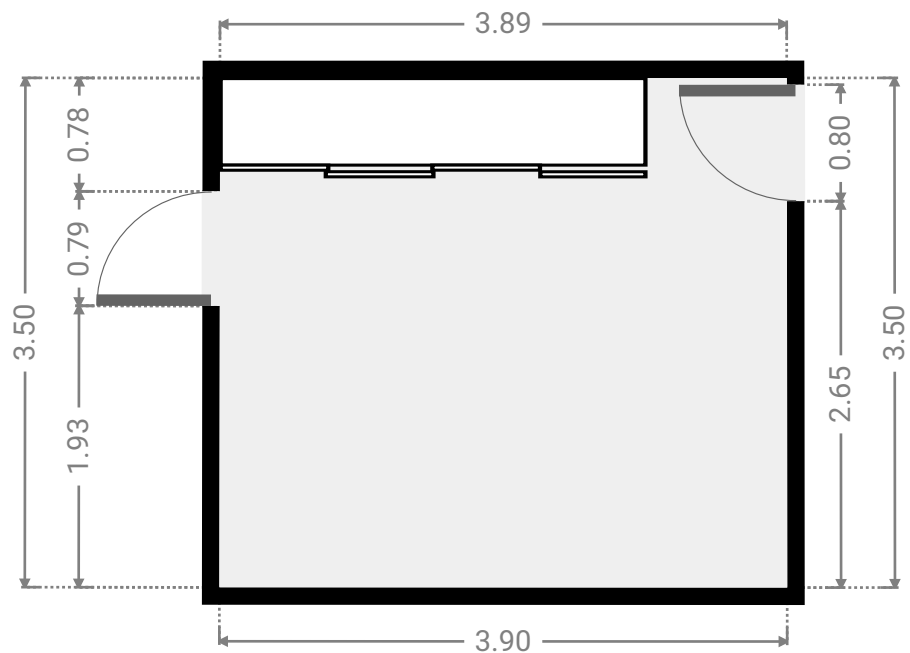
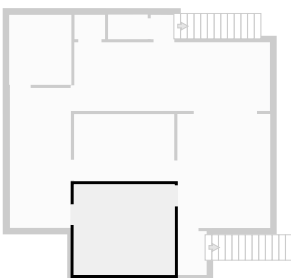

▼ **Bedroom**  
1st Floor

WIDTH: 3.86 m • LENGTH: 2.59 m  
AREA: 10.01 m<sup>2</sup> • PERIMETER: 12.91 m

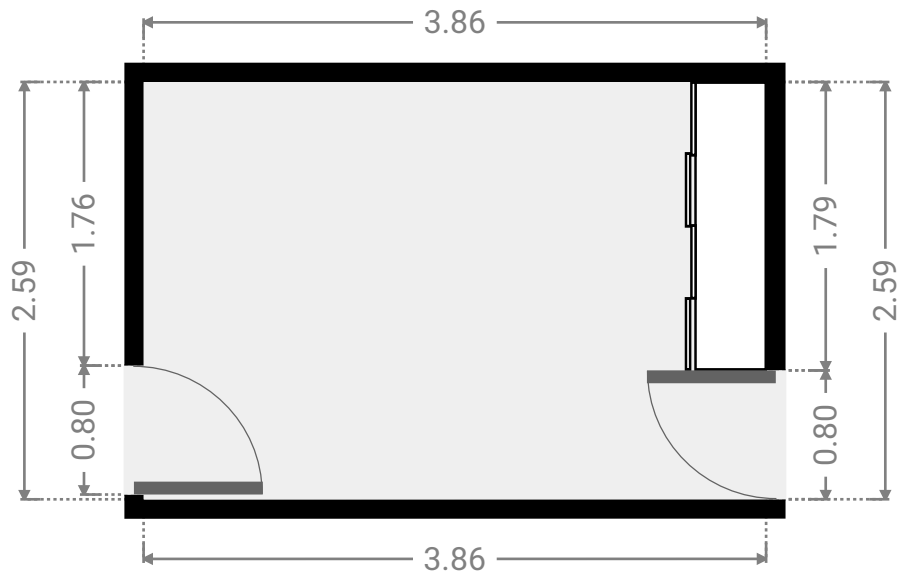
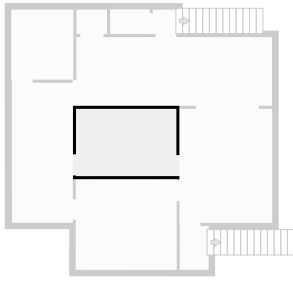

▼ **Hall**  
1st Floor

WIDTH: 0.91 m • LENGTH: 0.94 m  
AREA: 0.86 m<sup>2</sup> • PERIMETER: 3.70 m

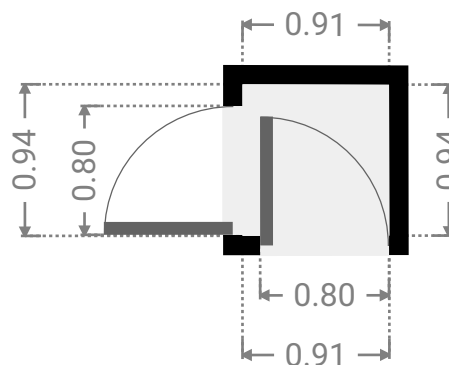

▼ **Hall**  
1st Floor

WIDTH: 1.12 m • LENGTH: 1.69 m  
AREA: 1.89 m<sup>2</sup> • PERIMETER: 5.62 m

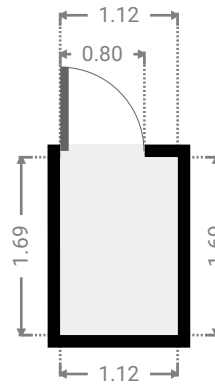
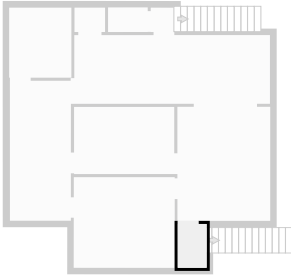

▼ **Kitchen**  
1st Floor

WIDTH: 7.55 m • LENGTH: 2.65 m  
AREA: 20.01 m<sup>2</sup> • PERIMETER: 20.40 m

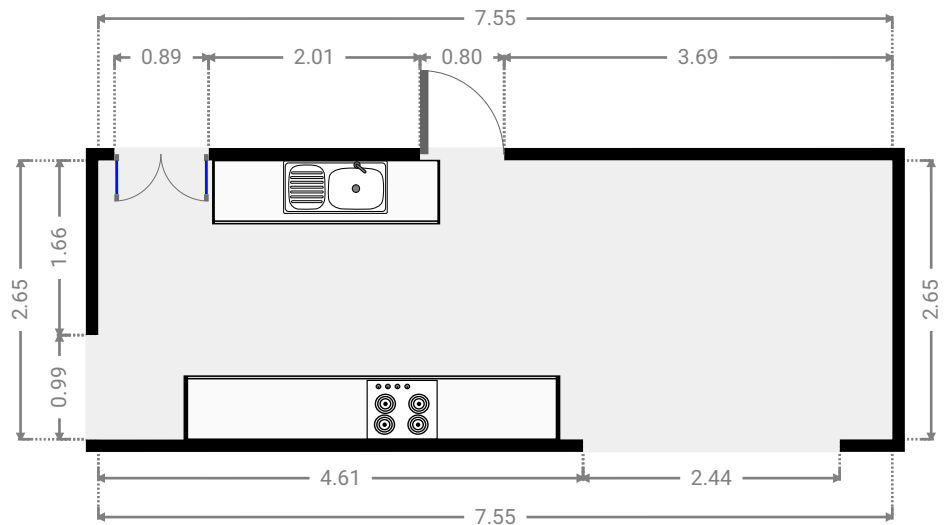
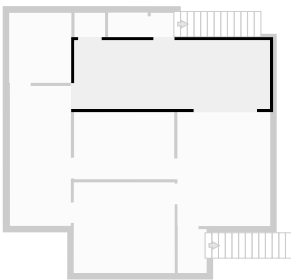



▼ **Closet**  
1st Floor

WIDTH: 1.18 m • LENGTH: 0.94 m  
AREA: 1.11 m<sup>2</sup> • PERIMETER: 4.24 m

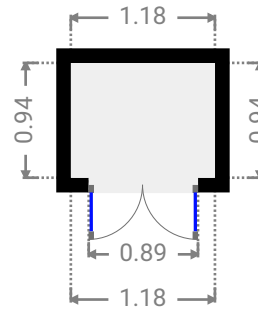

▼ **Living Room**  
1st Floor

WIDTH: 3.58 m • LENGTH: 4.40 m  
AREA: 15.76 m<sup>2</sup> • PERIMETER: 15.96 m

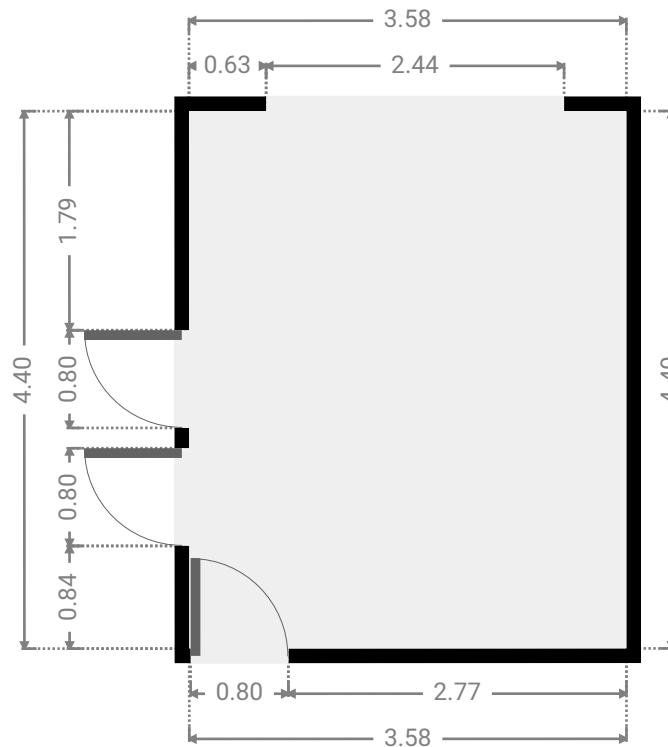
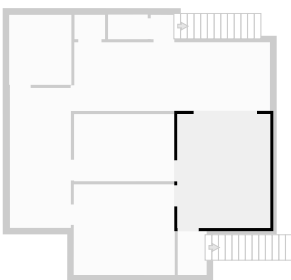

▼ **Living Room**  
1st Floor

WIDTH: 2.35 m • LENGTH: 5.40 m  
AREA: 12.70 m<sup>2</sup> • PERIMETER: 15.50 m

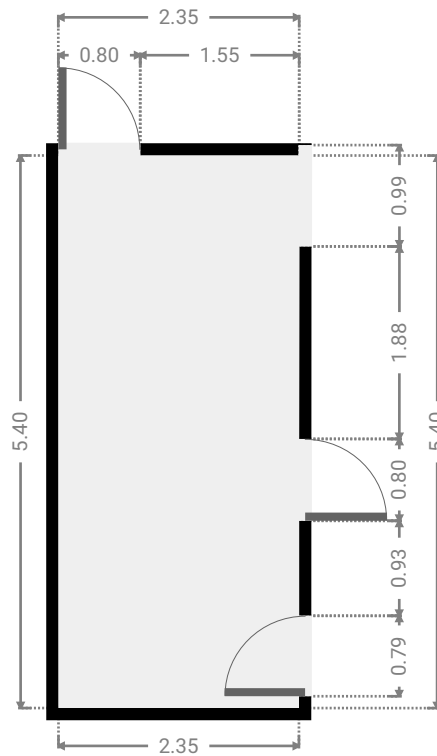
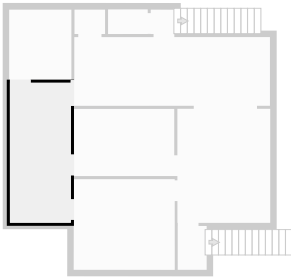

▼ **Toilet**  
1st Floor

WIDTH: 1.53 m • LENGTH: 0.95 m  
AREA: 1.45 m<sup>2</sup> • PERIMETER: 4.96 m

