

13 Mary Street

SUBMITTED BY

Ray White Rockhampton Casey
stockers@cqoz.com

CREATED ON

2022-09-14

Floors

2

▼ Ground Floor

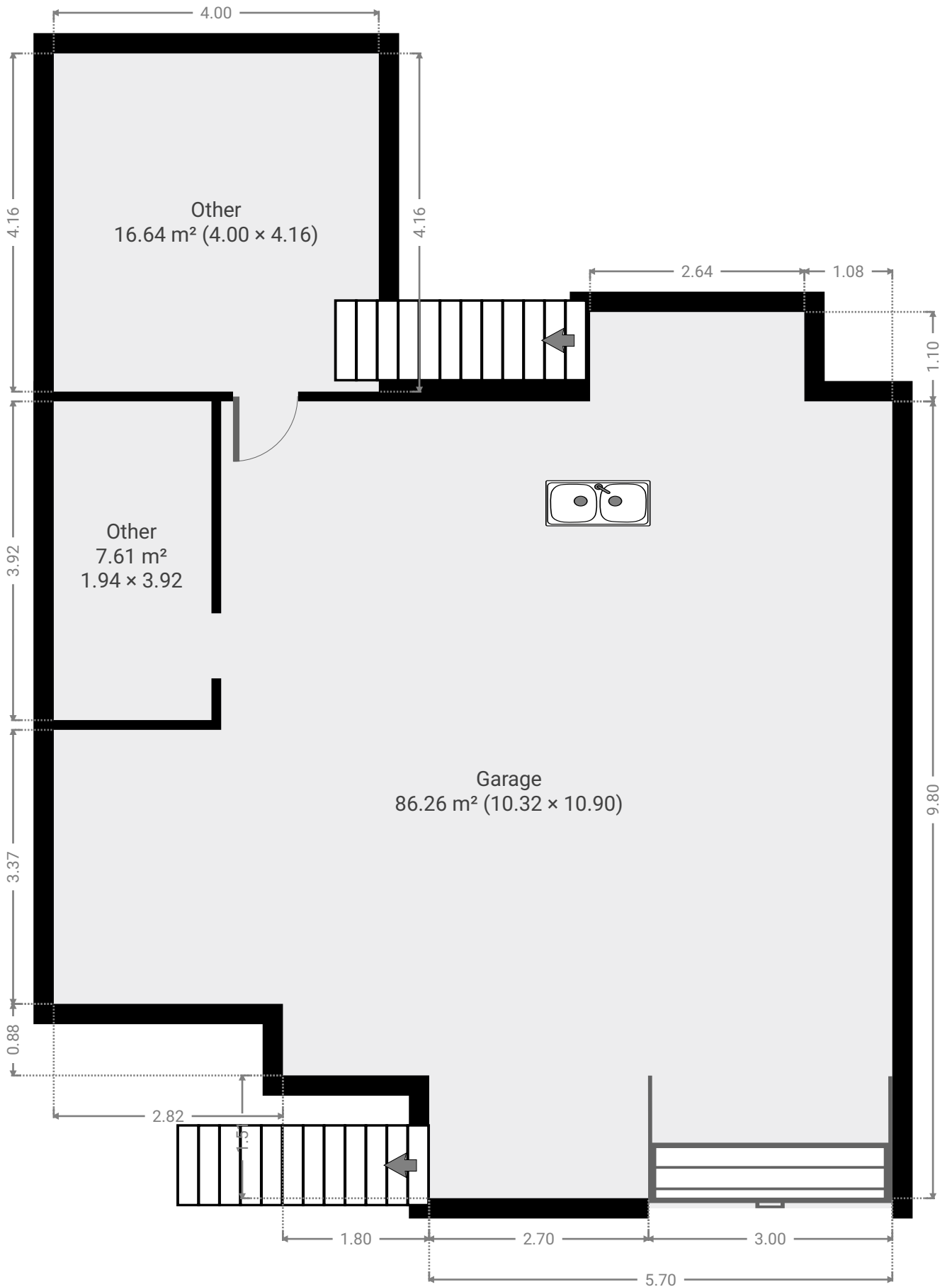

▼ Garage
Ground Floor

WIDTH: 10.32 m • LENGTH: 10.90 m
AREA: 86.26 m² • PERIMETER: 42.44 m

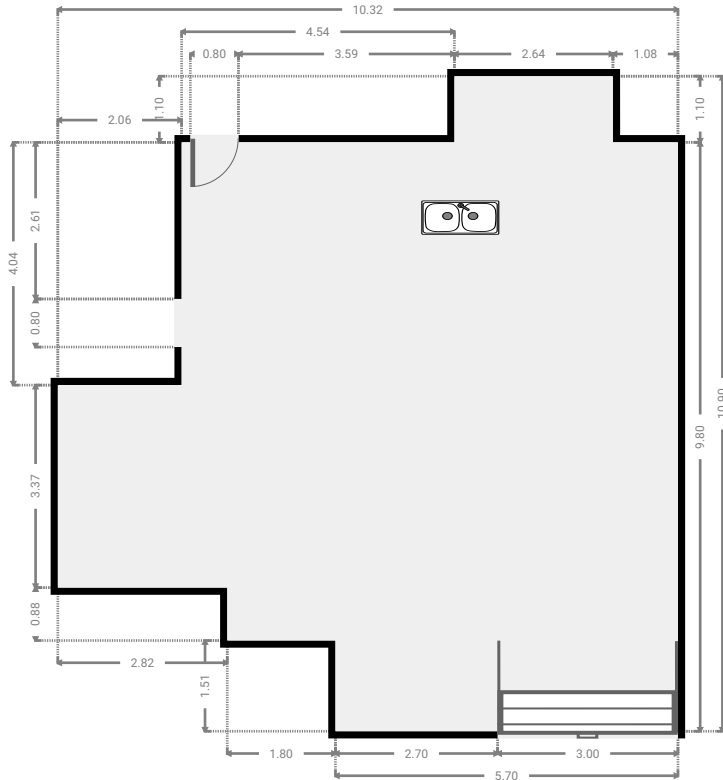
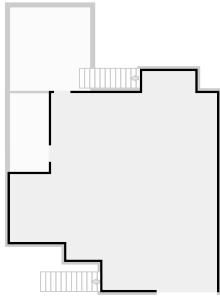

▼ Other
Ground Floor

WIDTH: 4.00 m • LENGTH: 4.16 m
AREA: 16.64 m² • PERIMETER: 16.32 m

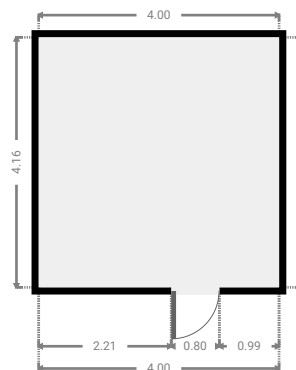
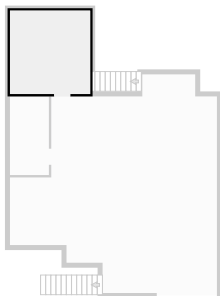

▼ Other
Ground Floor

WIDTH: 1.94 m • LENGTH: 3.92 m
AREA: 7.61 m² • PERIMETER: 11.72 m

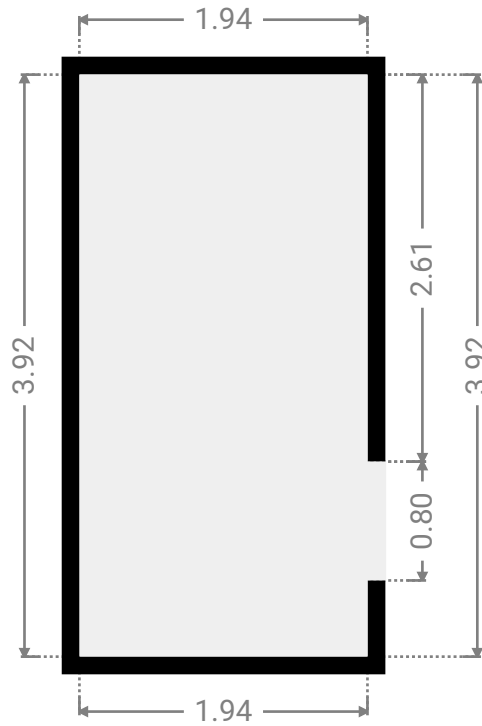
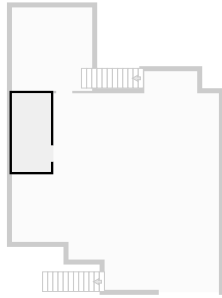

▼ 1st Floor



▼ **Bathroom**
1st Floor

WIDTH: 2.48 m • LENGTH: 3.04 m
AREA: 7.00 m² • PERIMETER: 11.04 m

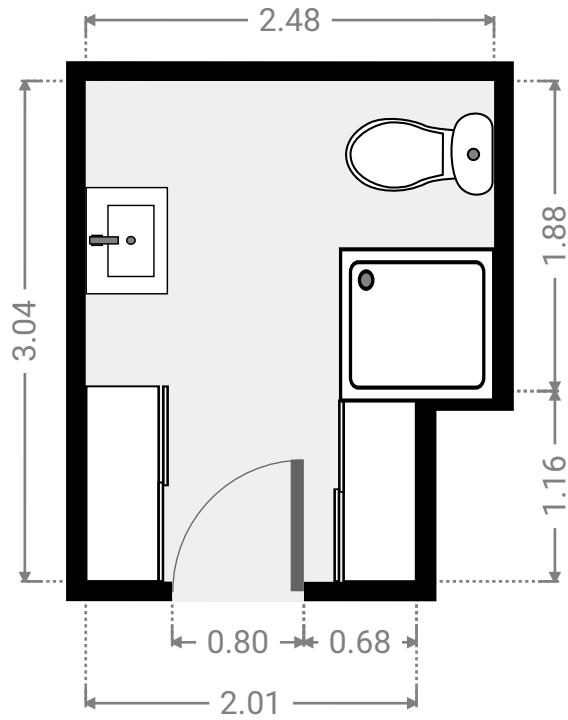
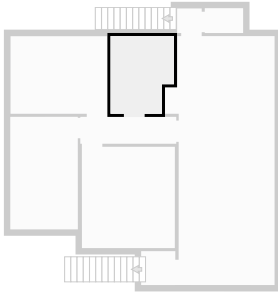

▼ **Bedroom**
1st Floor

WIDTH: 3.78 m • LENGTH: 3.03 m
AREA: 11.45 m² • PERIMETER: 13.62 m

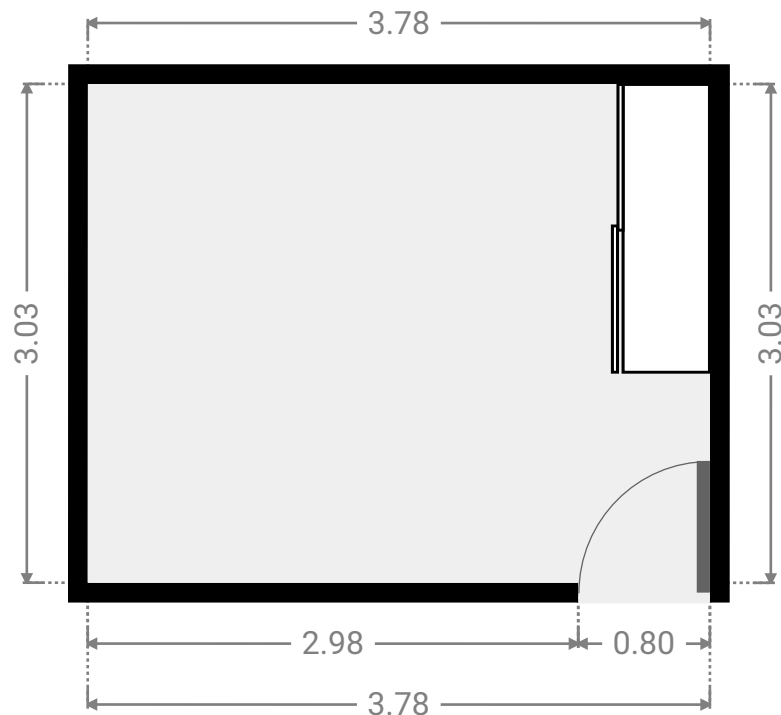
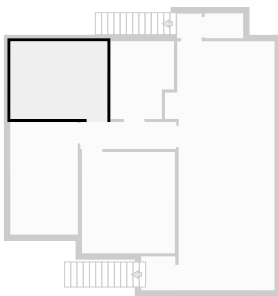

▼ **Bedroom**
1st Floor

WIDTH: 2.64 m • LENGTH: 4.40 m
AREA: 11.61 m² • PERIMETER: 14.08 m

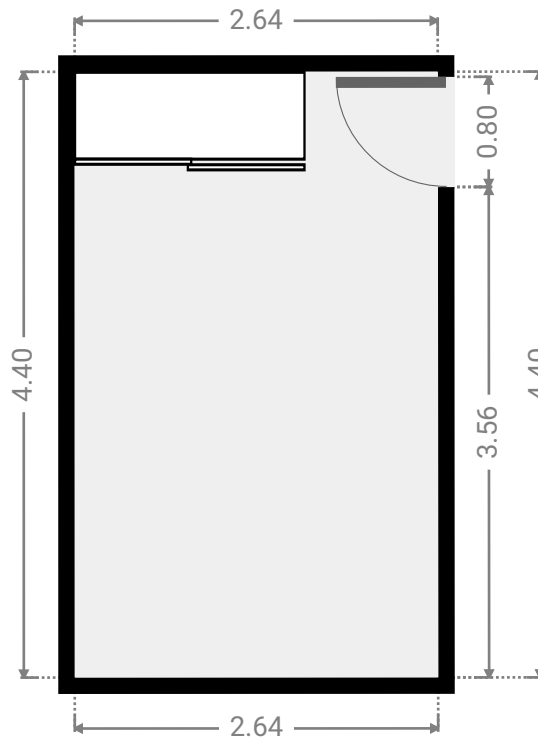
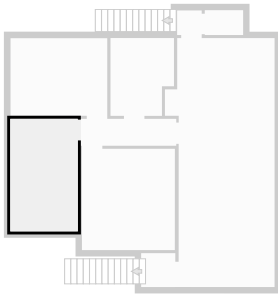

▼ **Bedroom**
1st Floor

WIDTH: 3.64 m • LENGTH: 3.96 m
AREA: 14.39 m² • PERIMETER: 15.19 m

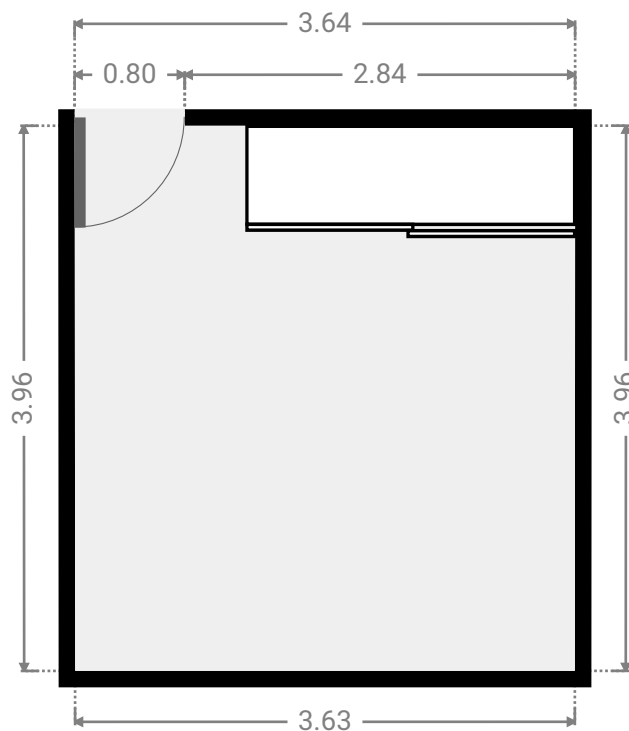
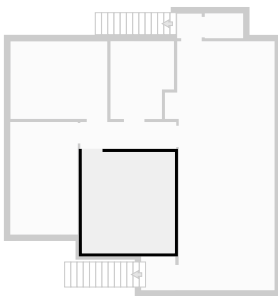

▼ **Hall**
1st Floor

WIDTH: 3.75 m • LENGTH: 1.05 m
AREA: 3.94 m² • PERIMETER: 9.60 m

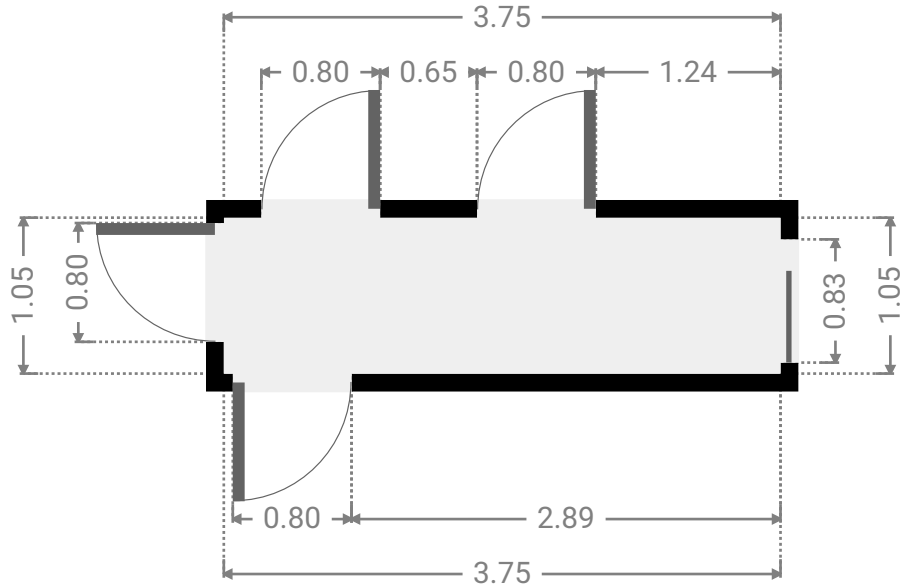
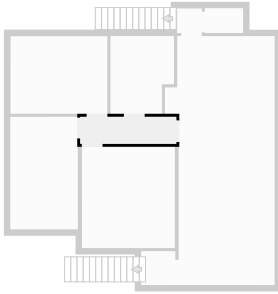

▼ **Hall**
1st Floor

WIDTH: 1.33 m • LENGTH: 1.32 m
AREA: 1.77 m² • PERIMETER: 5.32 m

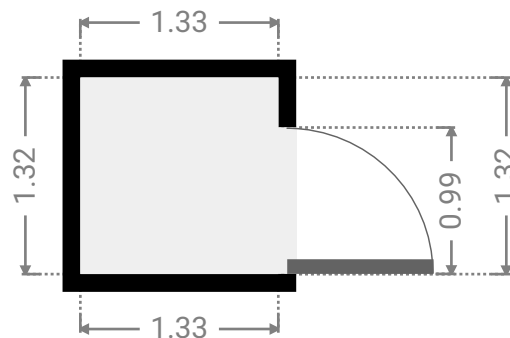
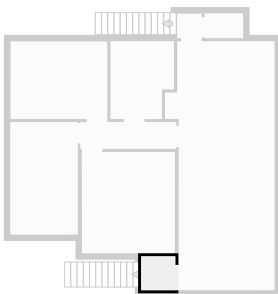

▼ **Hall**
1st Floor

WIDTH: 0.96 m • LENGTH: 0.96 m
AREA: 0.92 m² • PERIMETER: 3.84 m

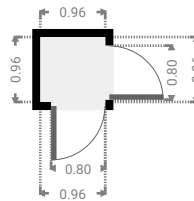
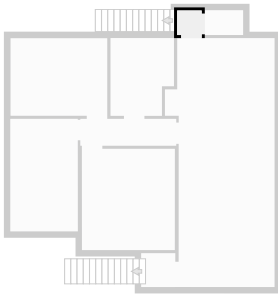

▼ **Kitchen**
1st Floor

WIDTH: 4.29 m • LENGTH: 9.73 m
AREA: 37.14 m² • PERIMETER: 28.03 m

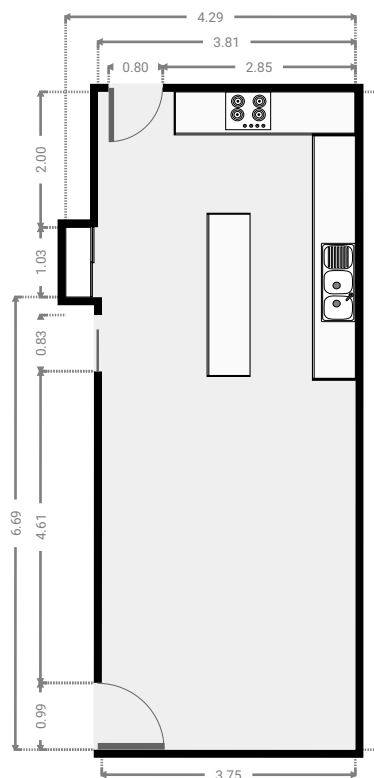
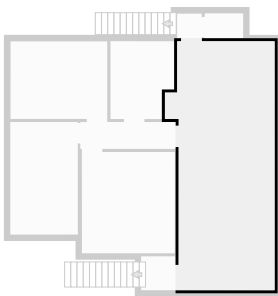

▼ Toilet
1st Floor

WIDTH: 1.50 m • LENGTH: 0.97 m
AREA: 1.46 m² • PERIMETER: 4.94 m

