

13 Macaulay Street

SUBMITTED BY
Janelle Casey
stockers@cqoz.com

CREATED ON
2021-10-28

Floors
1

▼ Ground Floor



FLOORS: 1

▼ **Bedroom**
Ground Floor

WIDTH: 3.00 m • LENGTH: 3.62 m
AREA: 10.86 m² • PERIMETER: 13.24 m

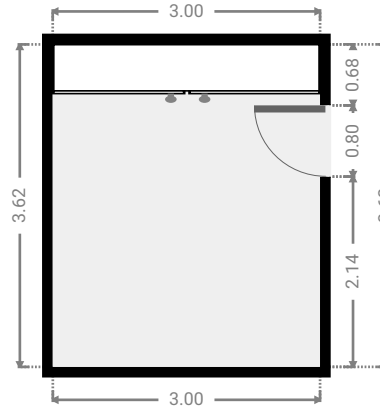
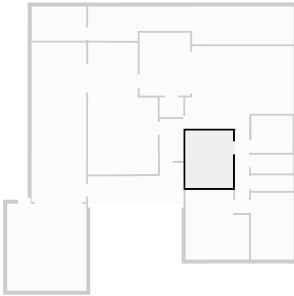

▼ **Carport**
Ground Floor

WIDTH: 5.00 m • LENGTH: 5.50 m
AREA: 27.50 m² • PERIMETER: 21.00 m

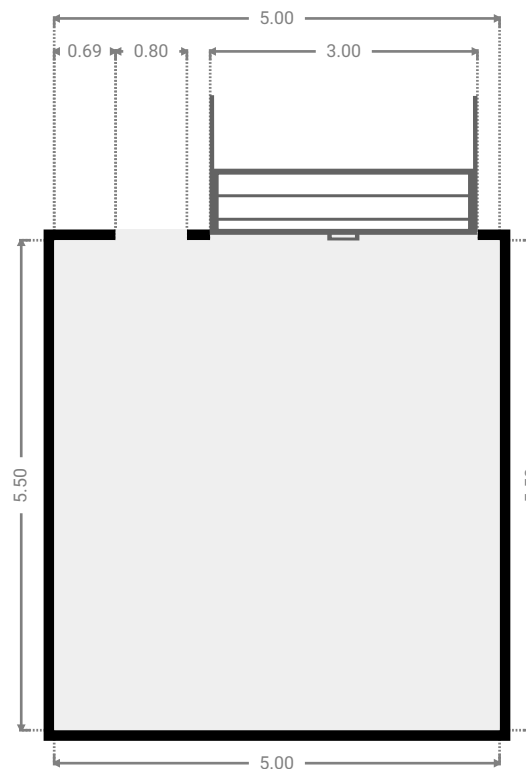
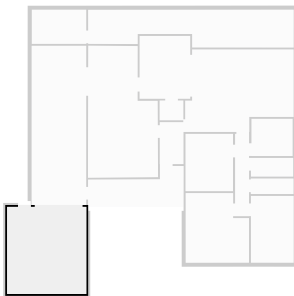

▼ Other Ground Floor

WIDTH: 6.04 m • LENGTH: 2.46 m
AREA: 11.03 m² • PERIMETER: 16.98 m

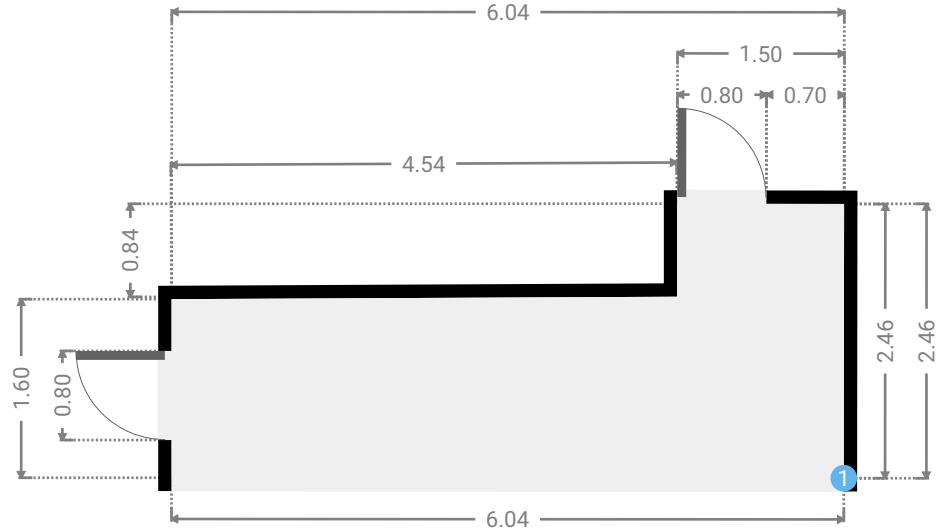
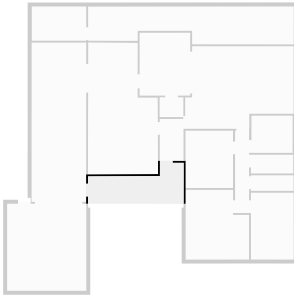

▼ Other/Ground Floor

1 OPENING

Height
0.00 m



FLOORS: 1

▼ Other Ground Floor

WIDTH: 12.99 m • LENGTH: 2.40 m
AREA: 27.37 m² • PERIMETER: 32.01 m

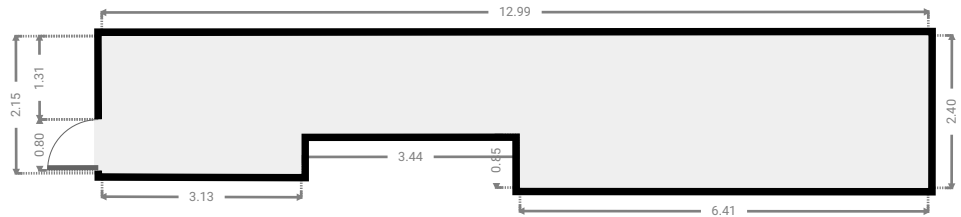
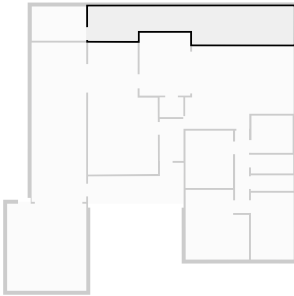

▼ Laundry Room Ground Floor

WIDTH: 3.44 m • LENGTH: 2.16 m
AREA: 7.43 m² • PERIMETER: 11.20 m

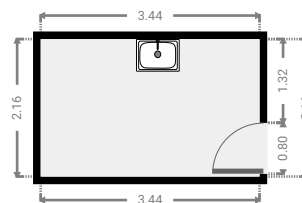
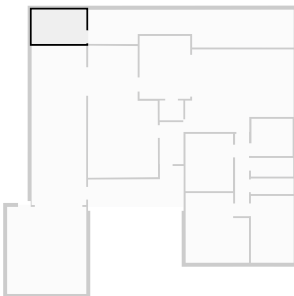

FLOORS: 1

▼ Bedroom
Ground Floor

WIDTH: 4.01 m • LENGTH: 4.40 m
AREA: 16.03 m² • PERIMETER: 16.81 m

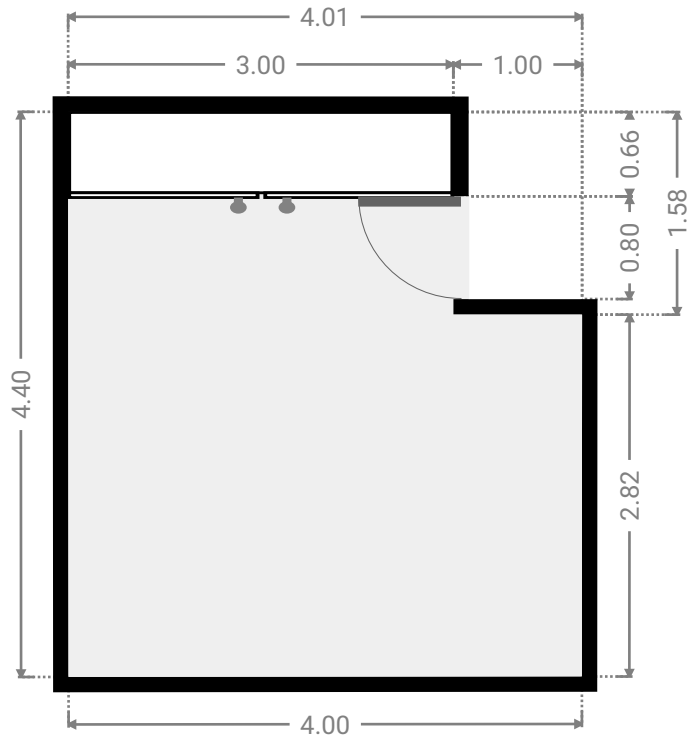
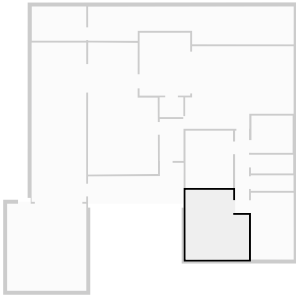

▼ Bedroom
Ground Floor

WIDTH: 2.71 m • LENGTH: 4.22 m
AREA: 11.39 m² • PERIMETER: 13.84 m

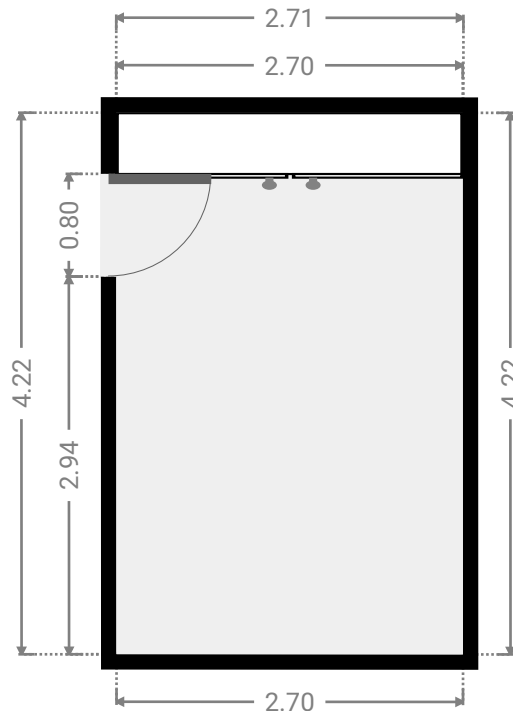
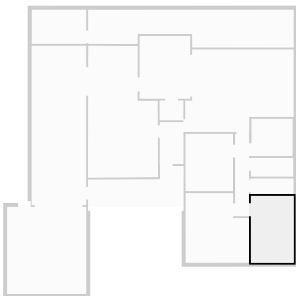

FLOORS: 1

▼ Toilet
Ground Floor

WIDTH: 2.70 m • LENGTH: 0.98 m
AREA: 2.65 m² • PERIMETER: 7.36 m

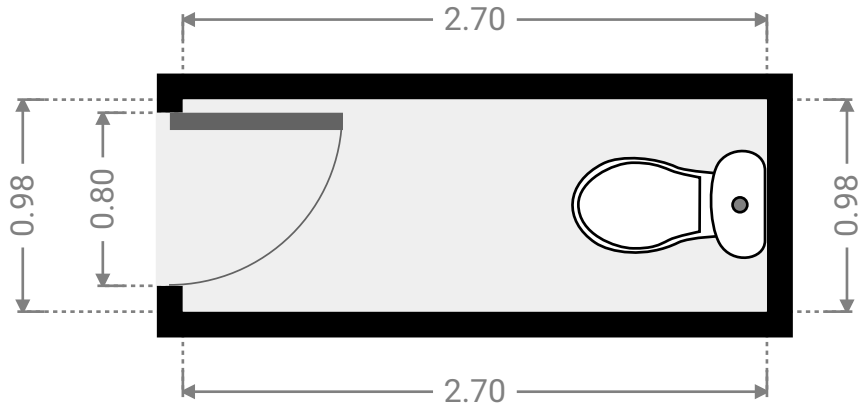
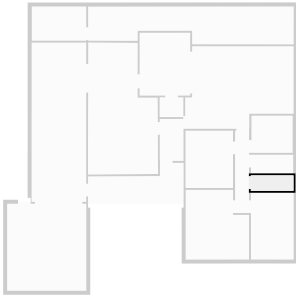

▼ Bathroom
Ground Floor

WIDTH: 2.67 m • LENGTH: 1.18 m
AREA: 3.15 m² • PERIMETER: 7.70 m

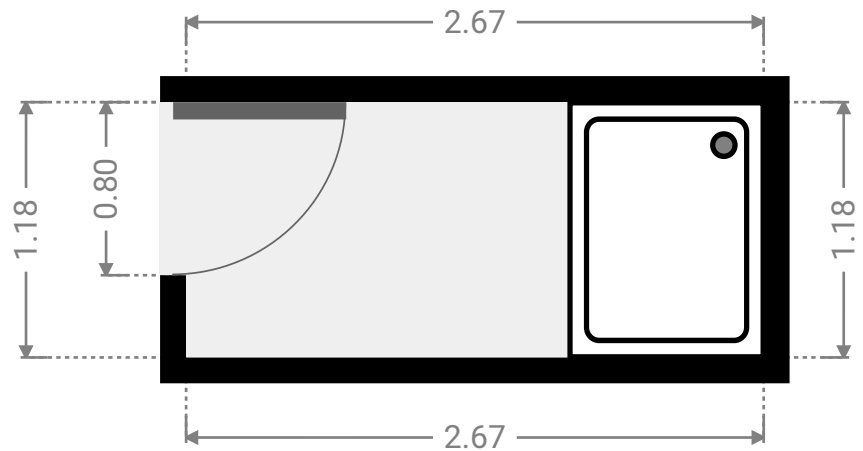
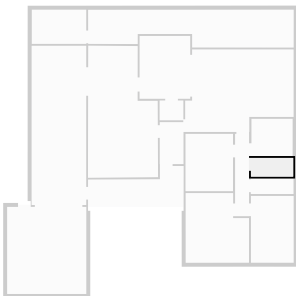

FLOORS: 1

▼ Living Room Ground Floor

WIDTH: 4.43 m • LENGTH: 8.35 m
AREA: 32.23 m² • PERIMETER: 25.46 m

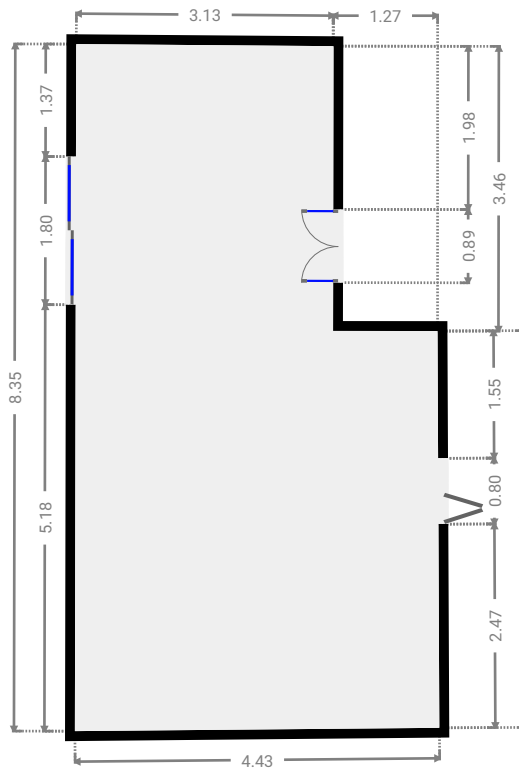
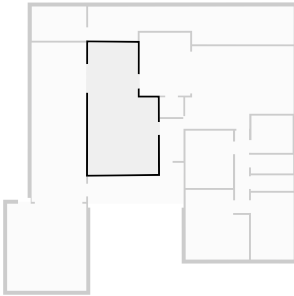

▼ Bathroom Ground Floor

WIDTH: 2.60 m • LENGTH: 2.35 m
AREA: 6.11 m² • PERIMETER: 9.90 m

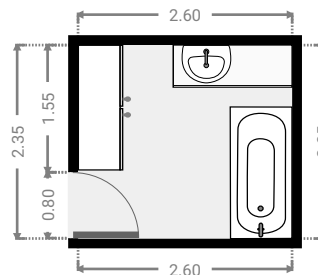
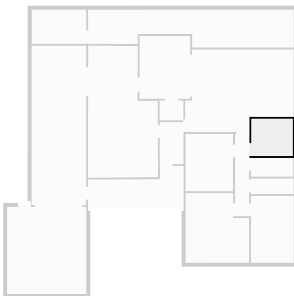

FLOORS: 1

▼ **Hallway**
Ground Floor

WIDTH: 0.88 m • LENGTH: 5.20 m
AREA: 4.58 m² • PERIMETER: 12.16 m

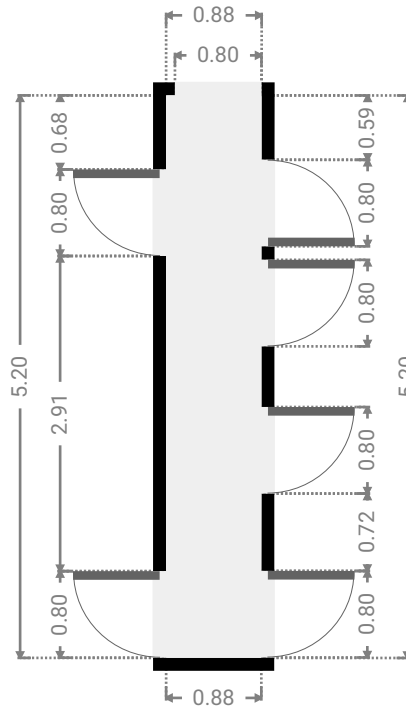
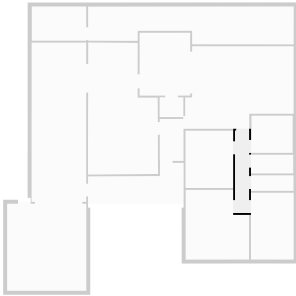

▼ **Living Room**
Ground Floor

WIDTH: 6.85 m • LENGTH: 5.22 m
AREA: 31.65 m² • PERIMETER: 24.13 m

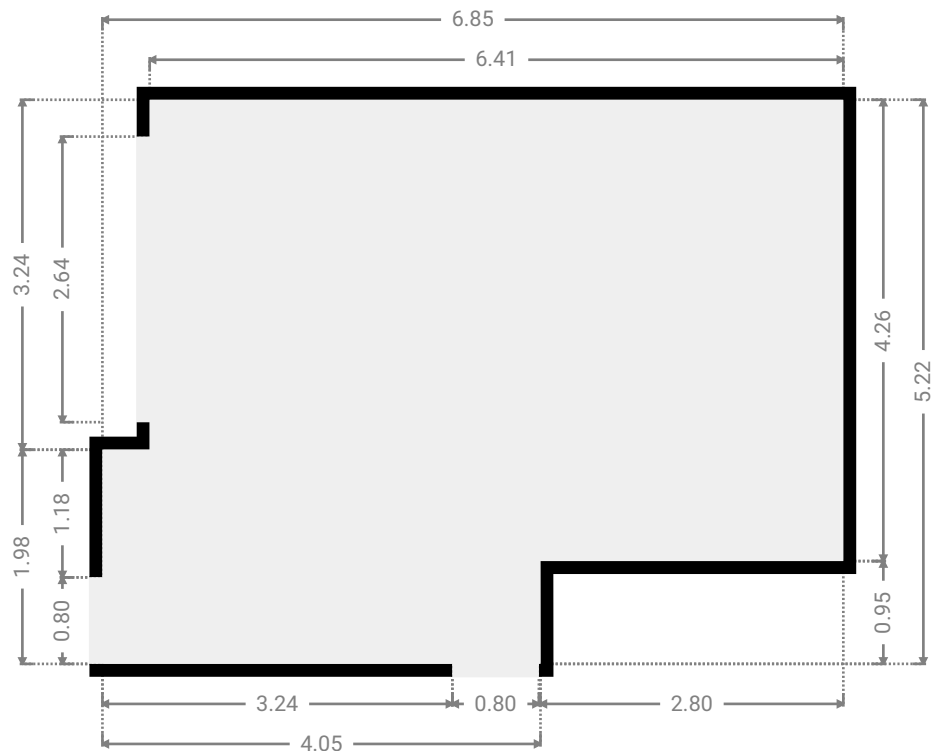
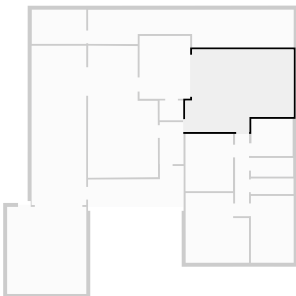

FLOORS: 1

▼ Hall
Ground Floor

WIDTH: 1.50 m • LENGTH: 2.65 m
AREA: 3.97 m² • PERIMETER: 8.30 m

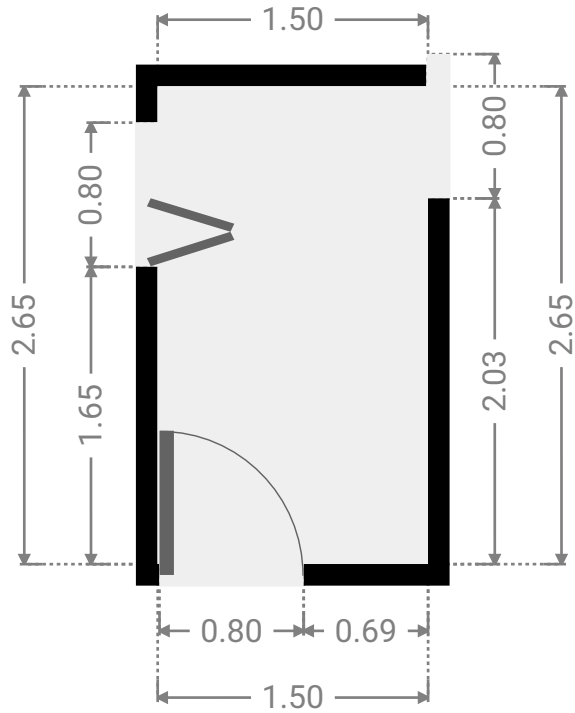
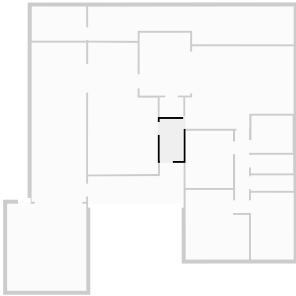

▼ Other
Ground Floor

WIDTH: 1.50 m • LENGTH: 1.25 m
AREA: 1.88 m² • PERIMETER: 5.50 m

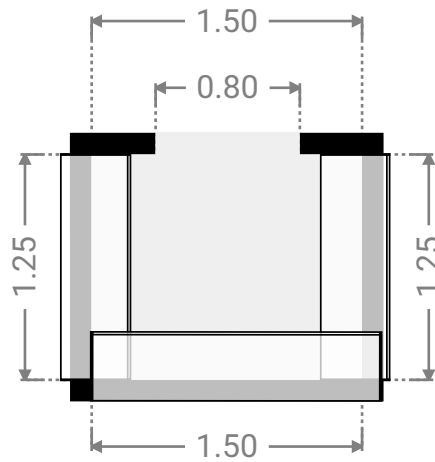

▼ Kitchen Ground Floor

WIDTH: 3.20 m • LENGTH: 3.97 m
AREA: 12.70 m² • PERIMETER: 14.34 m

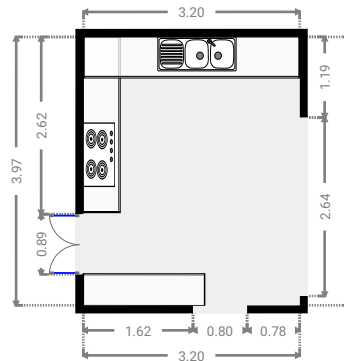
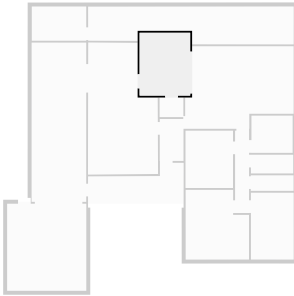

▼ Garage Ground Floor

WIDTH: 3.45 m • LENGTH: 10.06 m
AREA: 34.70 m² • PERIMETER: 27.02 m

