

13 LillyPilly Avenue

SUBMITTED BY

Ray White Rockhampton Casey
stockers@cqoz.com

CREATED ON

2022-11-23

Floors

2

▼ Ground Floor

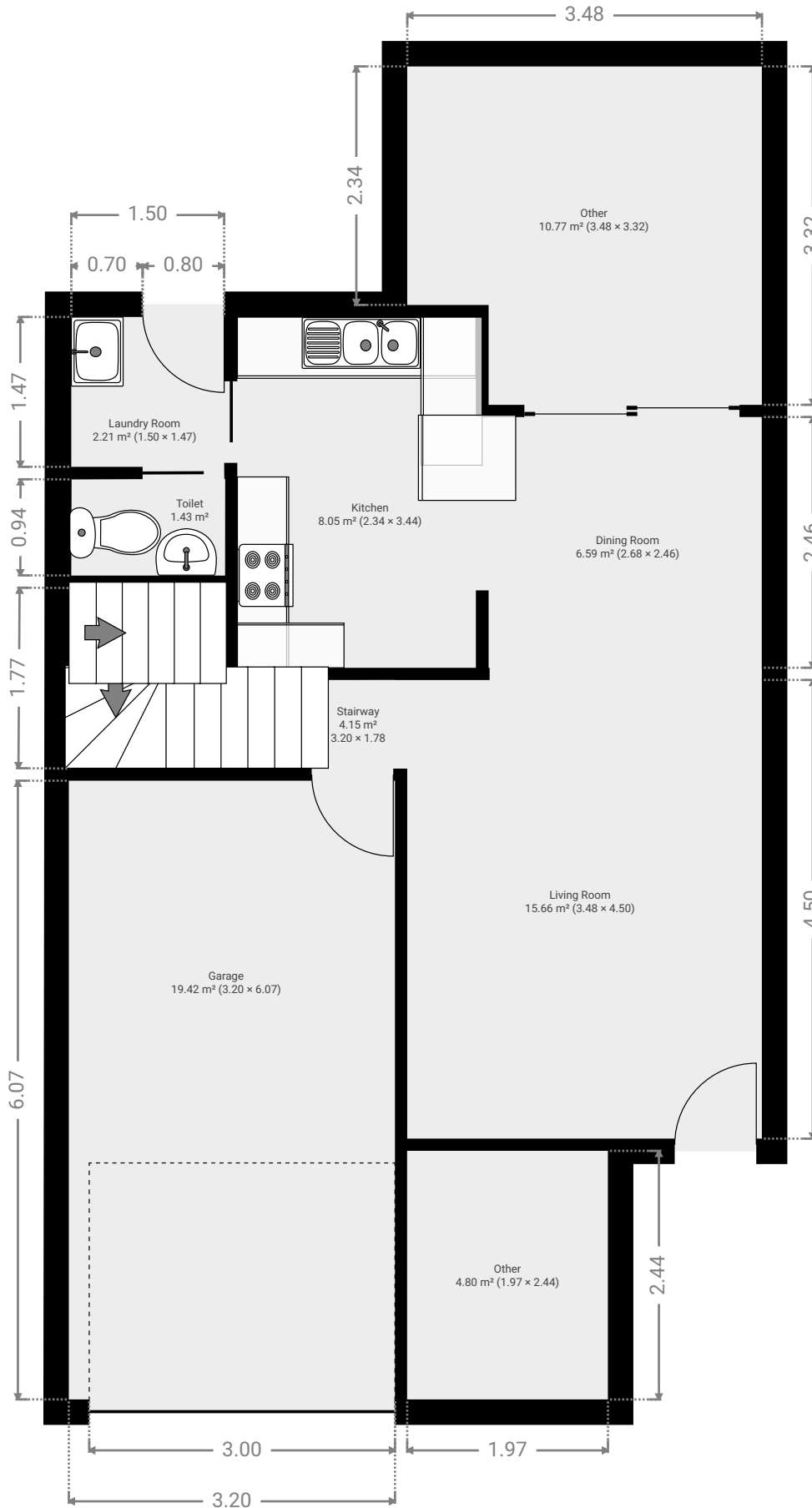

▼ Dining Room
Ground Floor

WIDTH: 2.68 m • LENGTH: 2.46 m
AREA: 6.59 m² • PERIMETER: 10.28 m

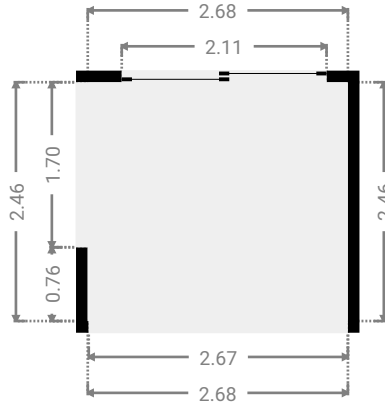
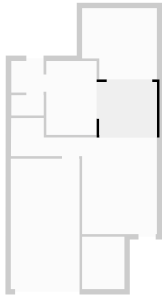

▼ Garage
Ground Floor

WIDTH: 3.20 m • LENGTH: 6.07 m
AREA: 19.42 m² • PERIMETER: 18.54 m

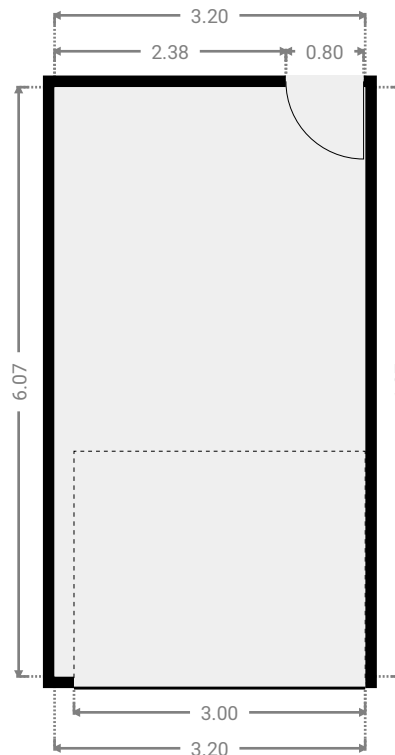
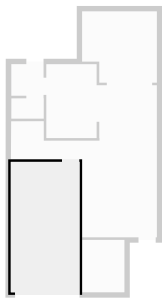

▼ **Kitchen**
Ground Floor

WIDTH: 2.34 m • LENGTH: 3.44 m
AREA: 8.05 m² • PERIMETER: 11.56 m

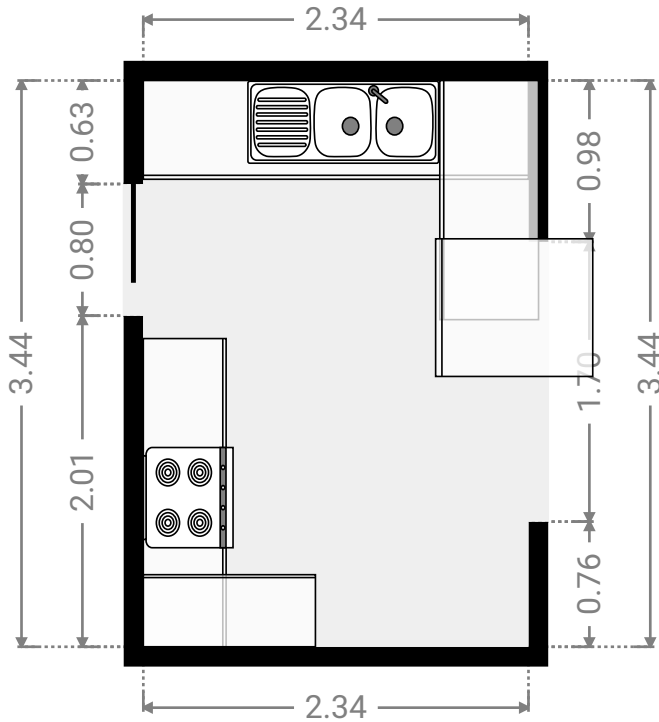
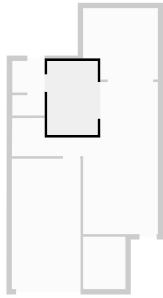

▼ **Laundry Room**
Ground Floor

WIDTH: 1.50 m • LENGTH: 1.47 m
AREA: 2.21 m² • PERIMETER: 5.94 m

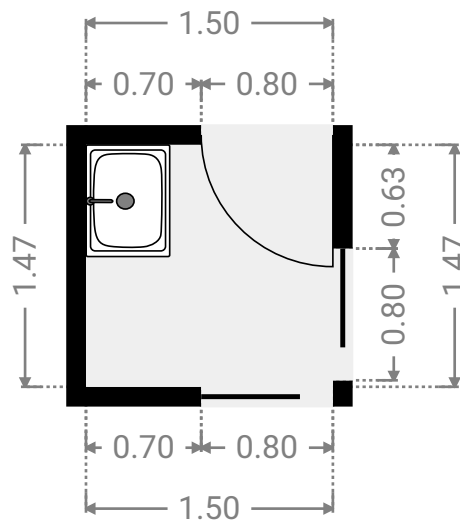
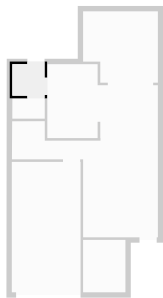

▼ **Living Room**
Ground Floor

WIDTH: 3.48 m • LENGTH: 4.50 m
AREA: 15.66 m² • PERIMETER: 15.96 m

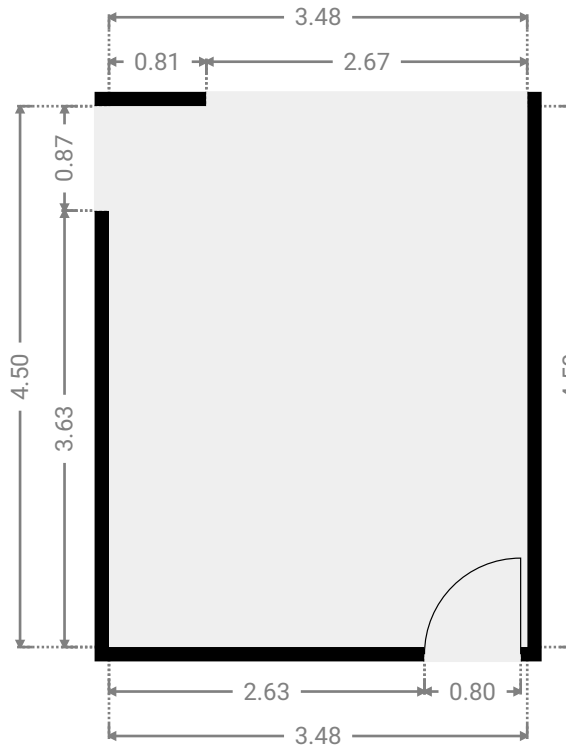
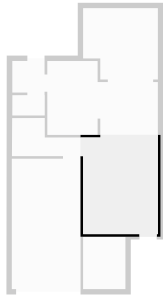

▼ **Other**
Ground Floor

WIDTH: 3.48 m • LENGTH: 3.32 m
AREA: 10.77 m² • PERIMETER: 13.60 m

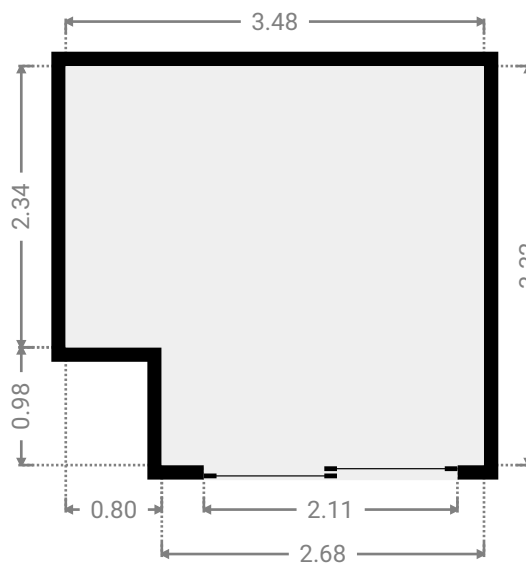
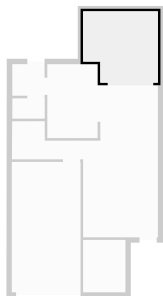

▼ **Other**
Ground Floor

WIDTH: 1.97 m • LENGTH: 2.44 m
AREA: 4.80 m² • PERIMETER: 8.82 m

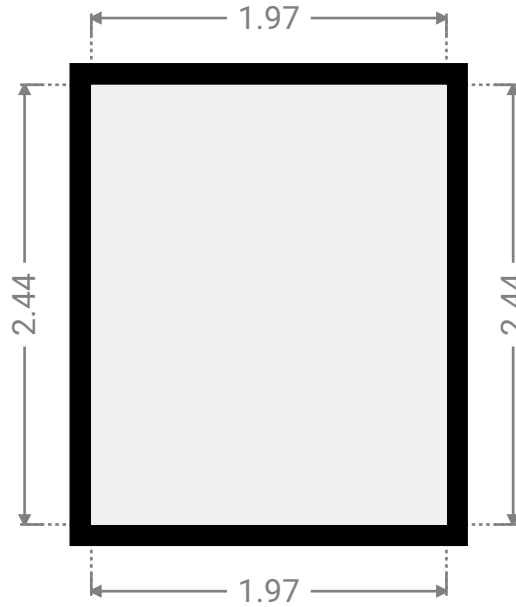
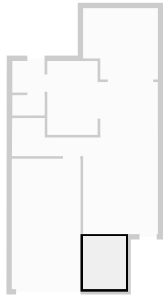

▼ **Stairway**
Ground Floor

WIDTH: 3.20 m • LENGTH: 1.78 m
AREA: 4.15 m² • PERIMETER: 9.93 m

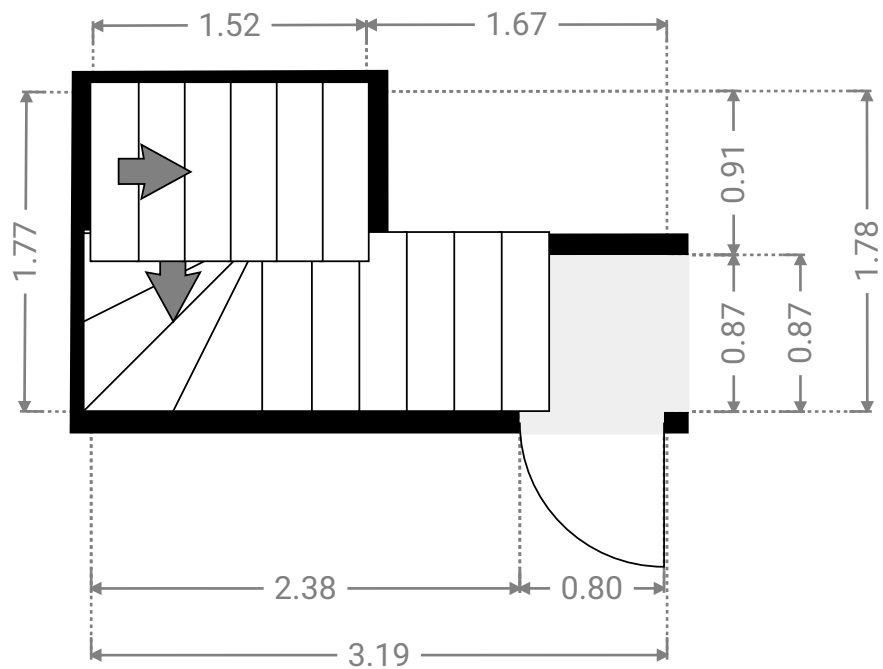
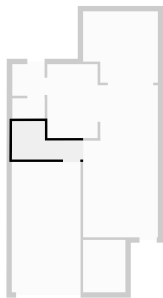

▼ Toilet
Ground Floor

WIDTH: 1.51 m • LENGTH: 0.95 m
AREA: 1.43 m² • PERIMETER: 4.91 m

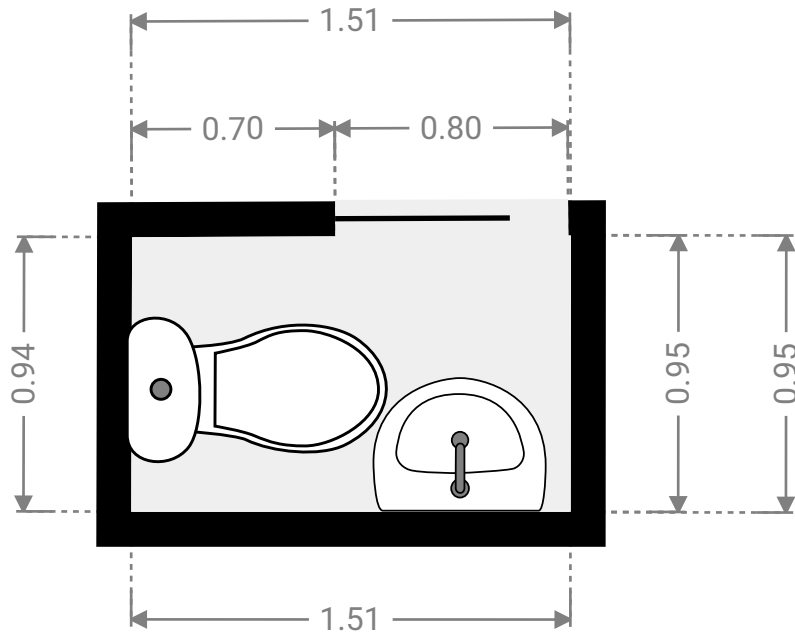
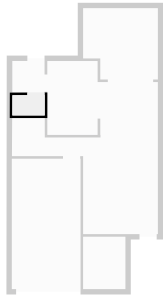

▼ 1st Floor

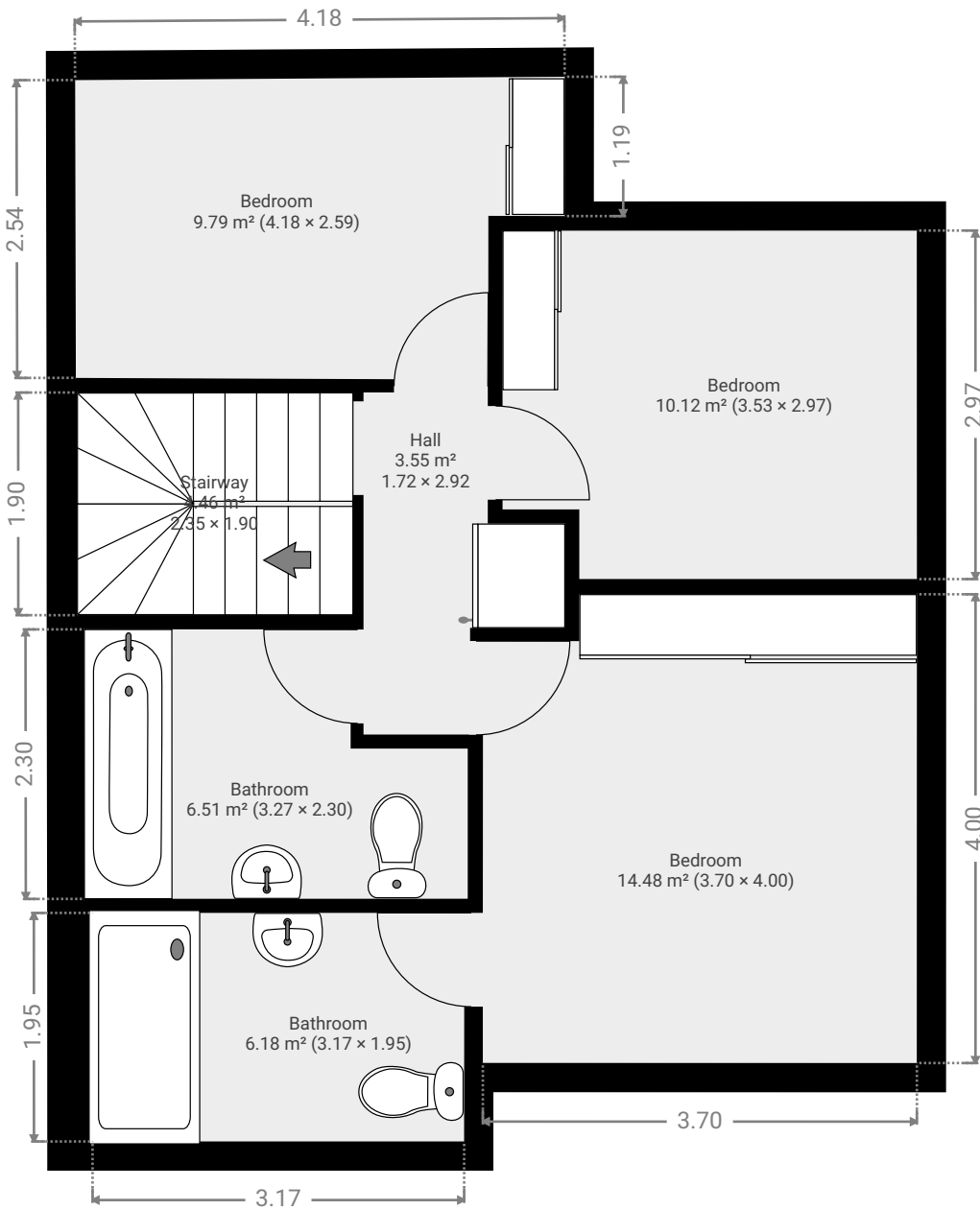

▼ **Bathroom**
1st Floor

WIDTH: 3.27 m • LENGTH: 2.30 m
AREA: 6.51 m² • PERIMETER: 11.14 m

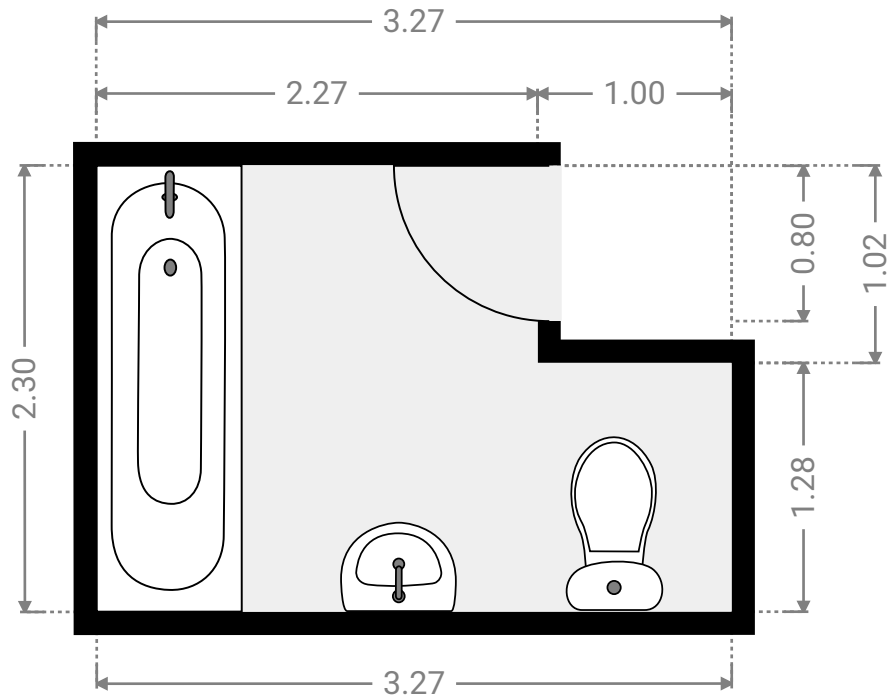
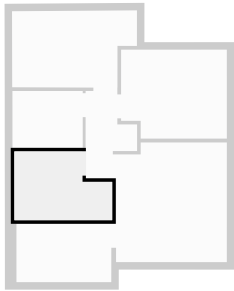

▼ **Bathroom**
1st Floor

WIDTH: 3.17 m • LENGTH: 1.95 m
AREA: 6.18 m² • PERIMETER: 10.24 m

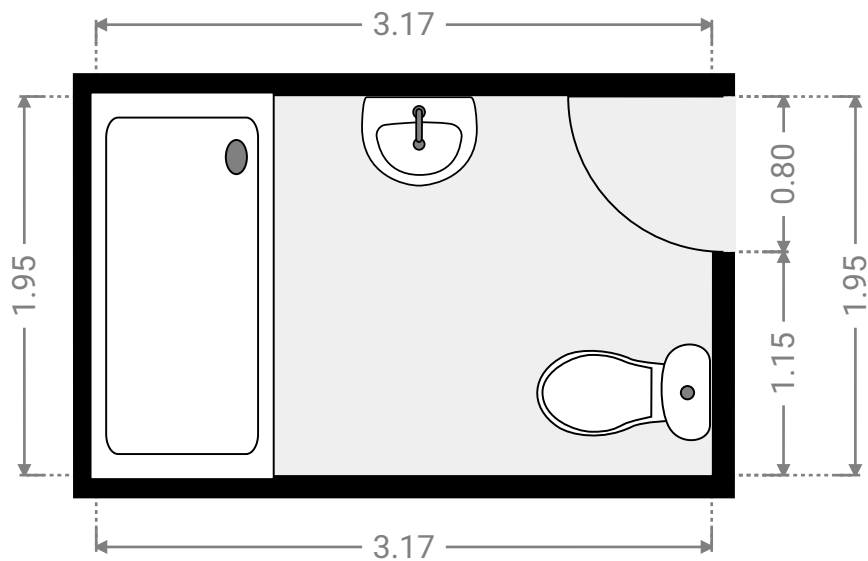
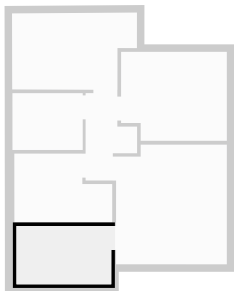

▼ **Bedroom**
1st Floor

WIDTH: 4.18 m • LENGTH: 2.59 m
AREA: 9.79 m² • PERIMETER: 13.47 m

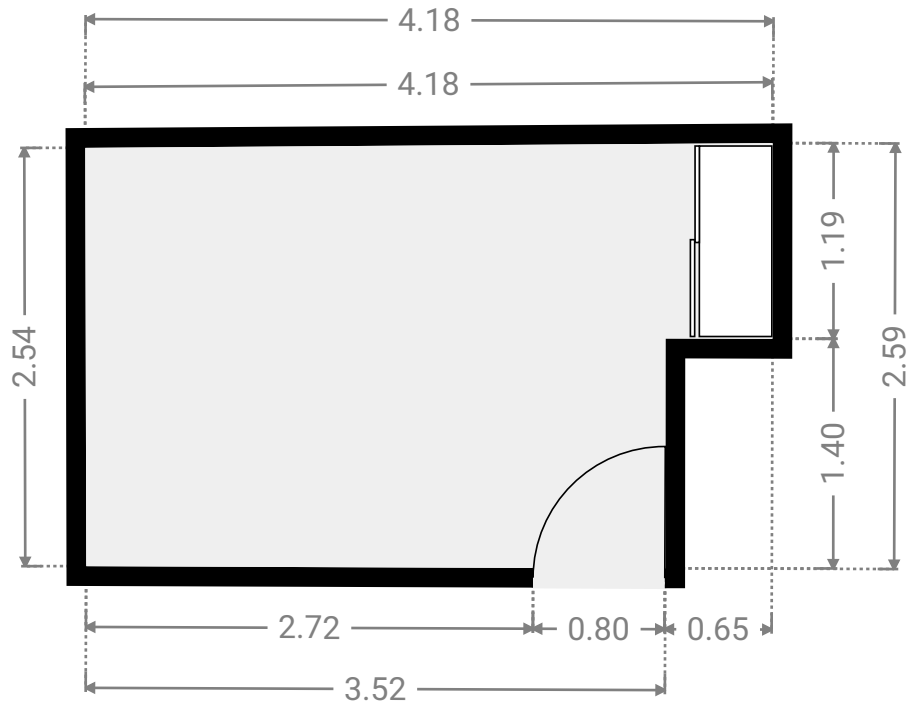
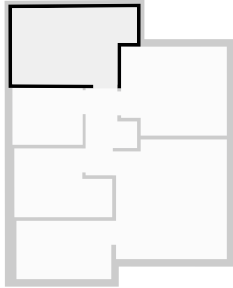

▼ **Bedroom**
1st Floor

WIDTH: 3.53 m • LENGTH: 2.97 m
AREA: 10.12 m² • PERIMETER: 13.01 m

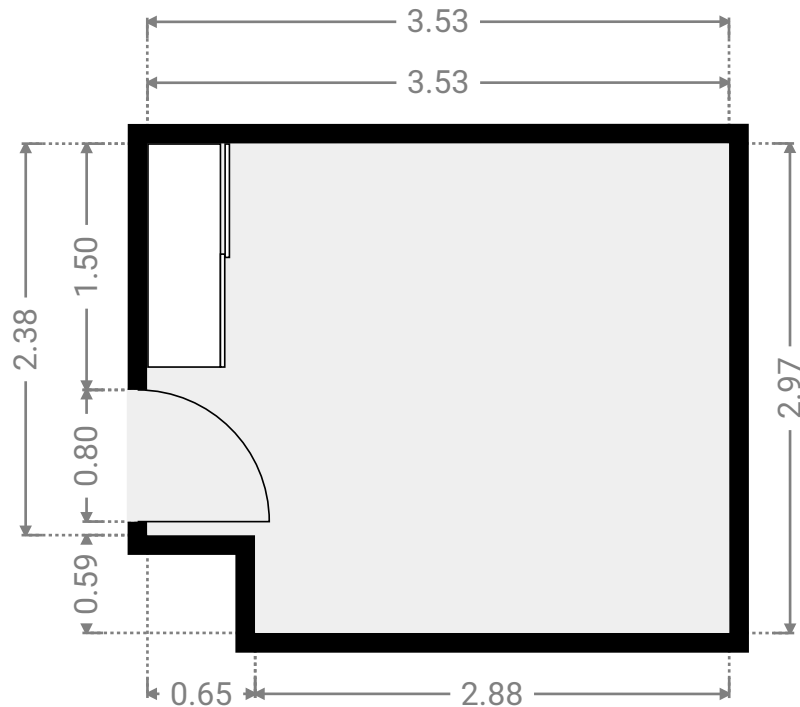
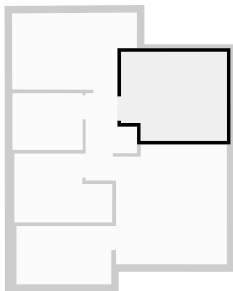

▼ **Bedroom**
1st Floor

WIDTH: 3.70 m • LENGTH: 4.00 m
AREA: 14.48 m² • PERIMETER: 15.40 m

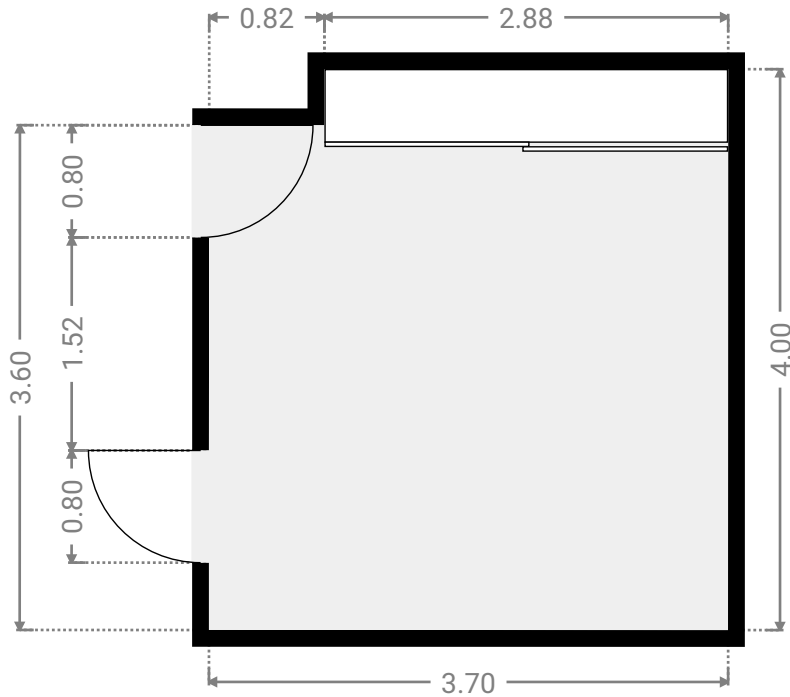
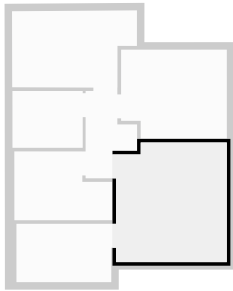

▼ **Hall**
1st Floor

WIDTH: 1.72 m • LENGTH: 2.92 m
AREA: 3.55 m² • PERIMETER: 9.28 m

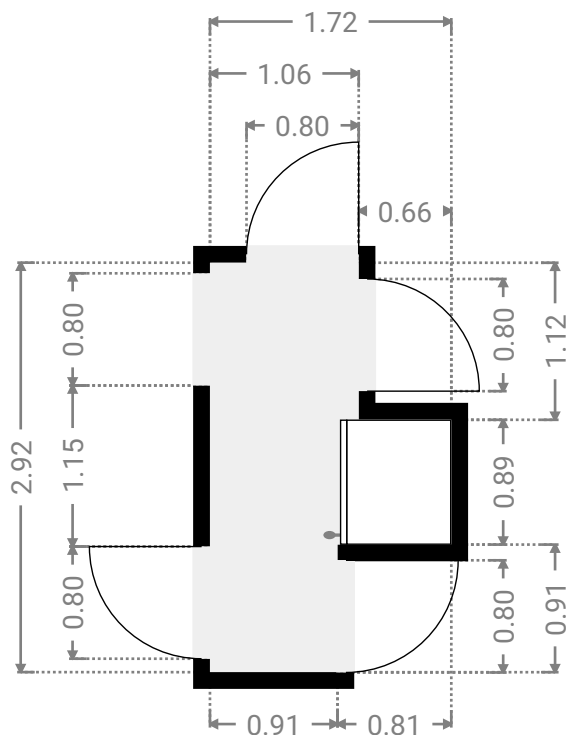
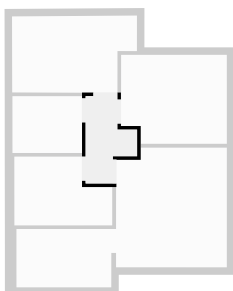

▼ **Stairway**
1st Floor

WIDTH: 2.35 m • LENGTH: 1.90 m
AREA: 4.46 m² • PERIMETER: 8.50 m

