

# 129 Stamford Street

**SUBMITTED BY**

Ray White Rockhampton Casey  
stockers@cqoz.com

---

**CREATED ON**

2022-08-22

---

**Floors**

1

---

▼ Ground Floor



FLOORS: 1

▼ **Bathroom**  
Ground Floor

WIDTH: 1.82 m • LENGTH: 2.56 m  
AREA: 4.66 m<sup>2</sup> • PERIMETER: 8.75 m

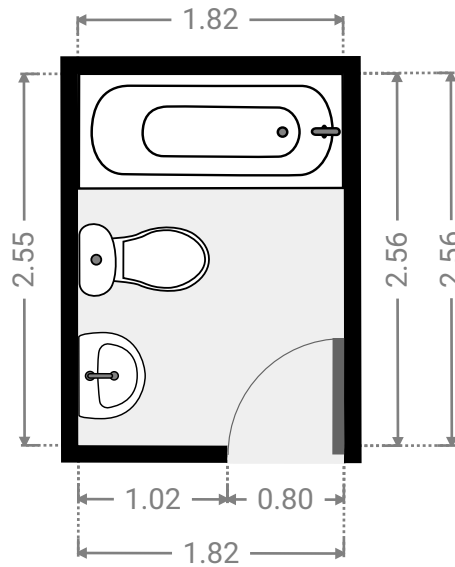
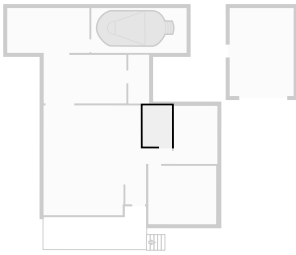

▼ **Bedroom**  
Ground Floor

WIDTH: 4.24 m • LENGTH: 3.65 m  
AREA: 15.48 m<sup>2</sup> • PERIMETER: 15.78 m

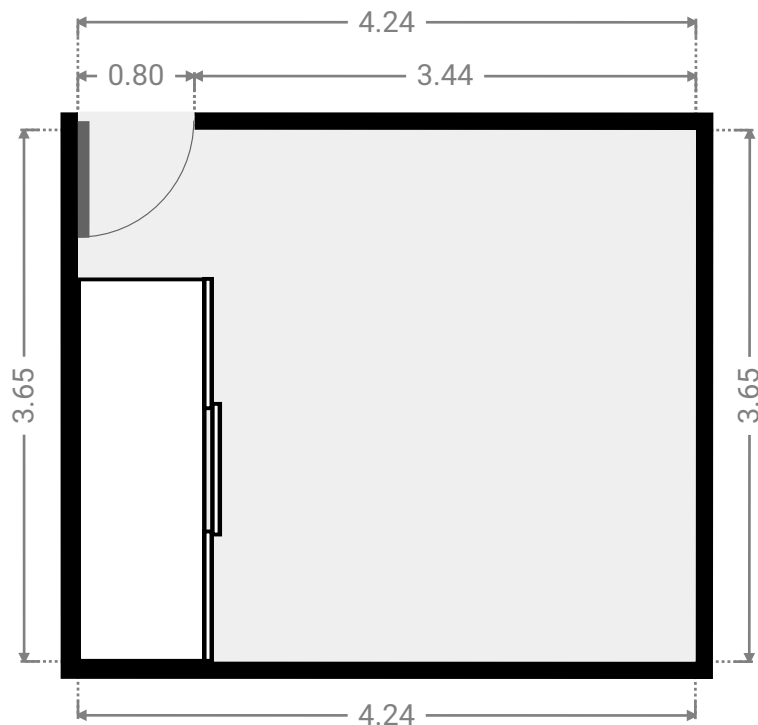
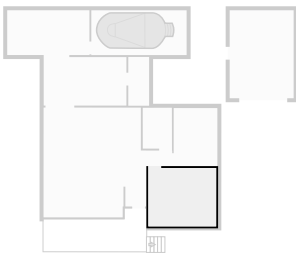

FLOORS: 1

▼ **Bedroom**  
Ground Floor

WIDTH: 2.73 m • LENGTH: 3.63 m  
AREA: 9.91 m<sup>2</sup> • PERIMETER: 12.72 m

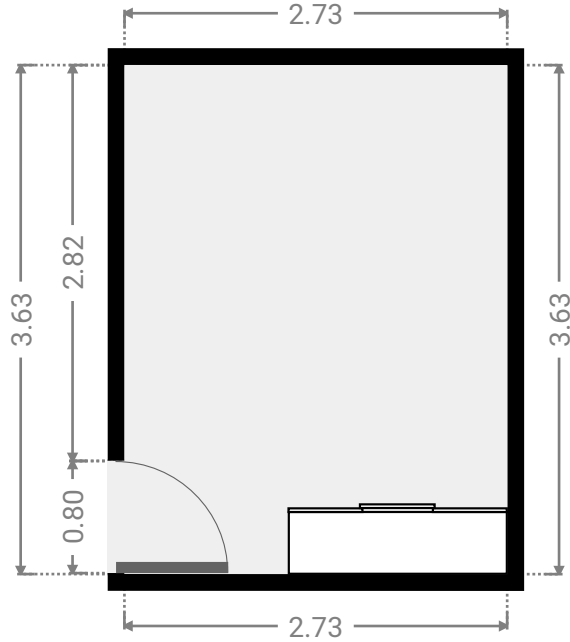
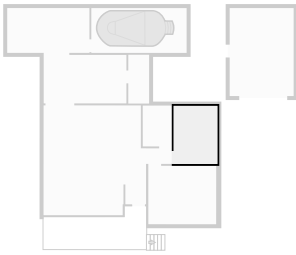

▼ **Deck**  
Ground Floor

WIDTH: 5.14 m • LENGTH: 2.80 m  
AREA: 14.39 m<sup>2</sup> • PERIMETER: 15.88 m

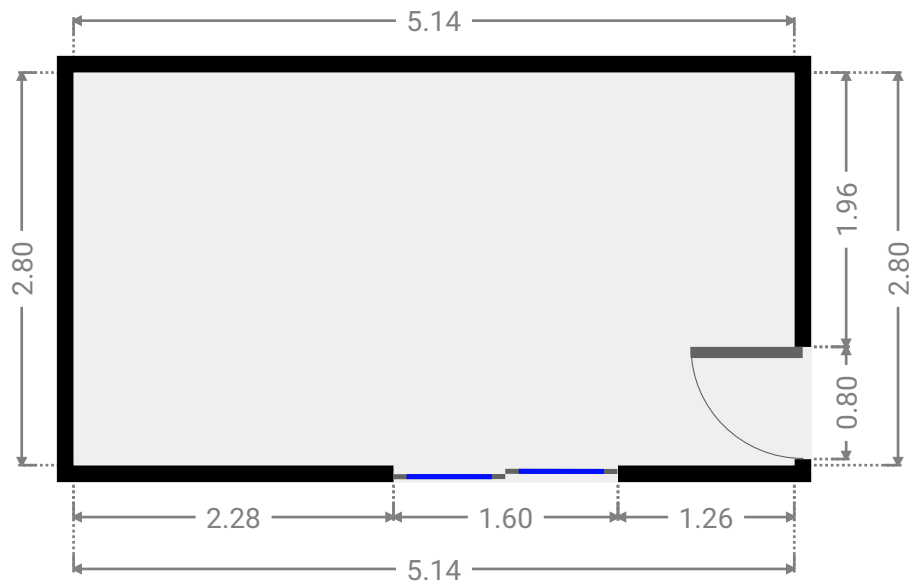

▼ Garage  
Ground Floor

WIDTH: 4.00 m • LENGTH: 5.50 m  
AREA: 22.00 m<sup>2</sup> • PERIMETER: 19.00 m

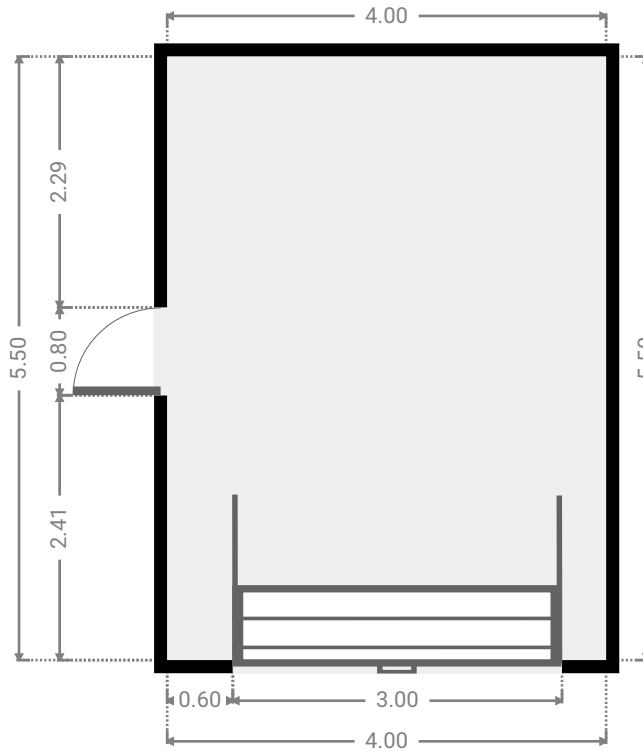
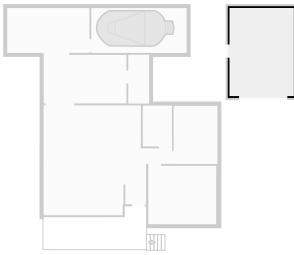

▼ Hall  
Ground Floor

WIDTH: 1.53 m • LENGTH: 0.97 m  
AREA: 1.48 m<sup>2</sup> • PERIMETER: 5.00 m

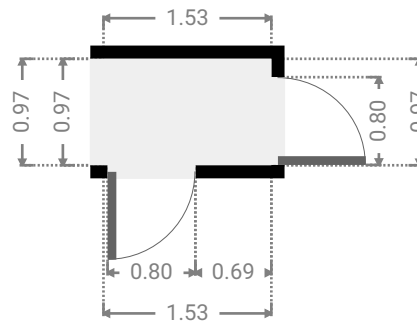
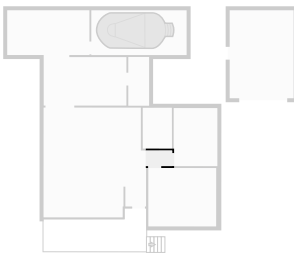

FLOORS: 1

▼ **Laundry Room**  
Ground Floor

WIDTH: 1.30 m • LENGTH: 3.05 m  
AREA: 3.96 m<sup>2</sup> • PERIMETER: 8.70 m

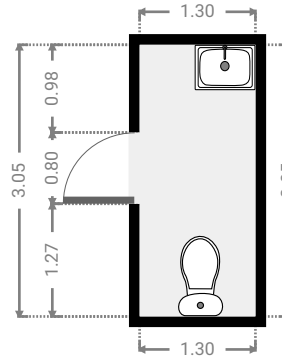

▼ **Living Room**  
Ground Floor

WIDTH: 6.41 m • LENGTH: 6.87 m  
AREA: 41.96 m<sup>2</sup> • PERIMETER: 29.02 m

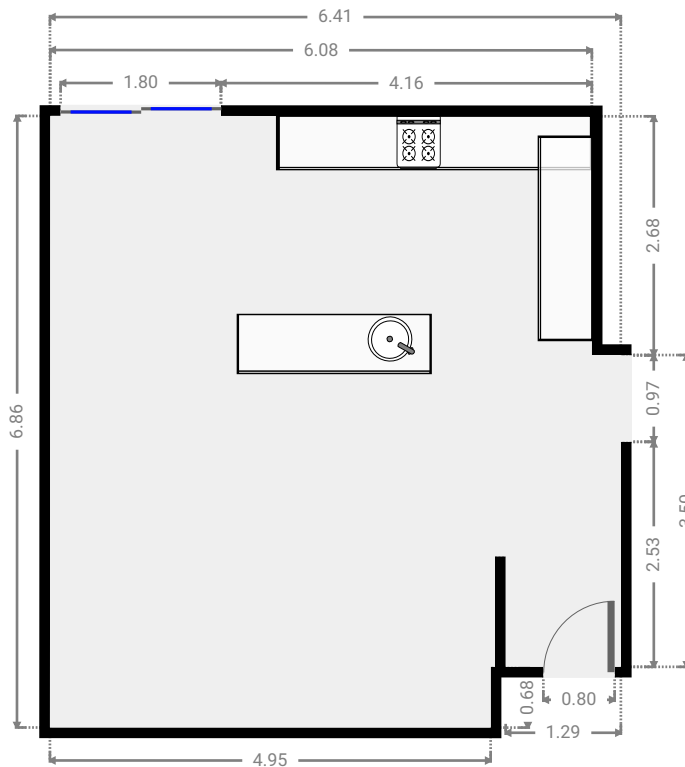
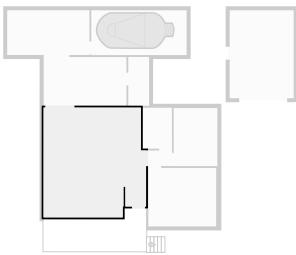

FLOORS: 1

▼ Deck  
Ground Floor

WIDTH: 6.43 m • LENGTH: 2.69 m  
AREA: 13.79 m<sup>2</sup> • PERIMETER: 18.22 m

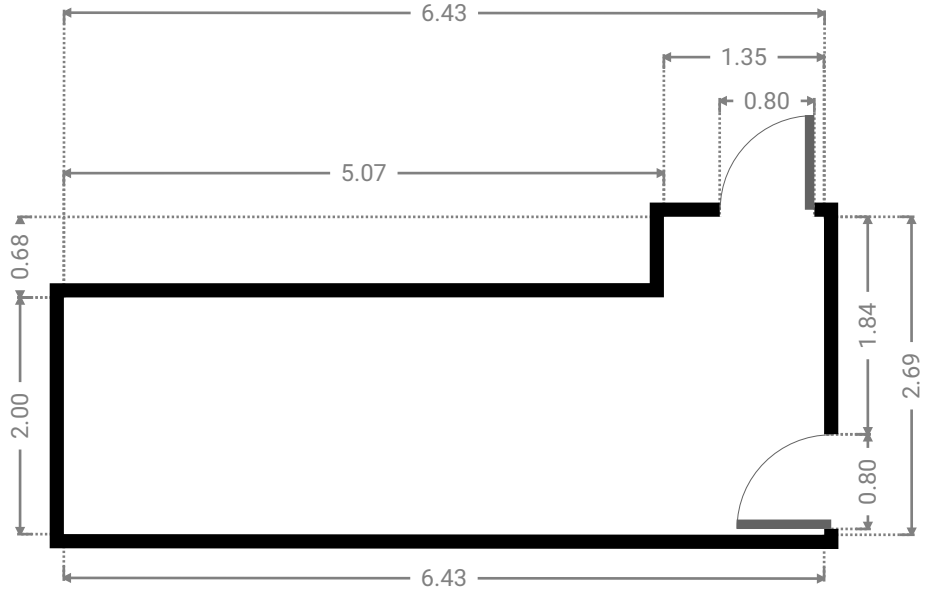
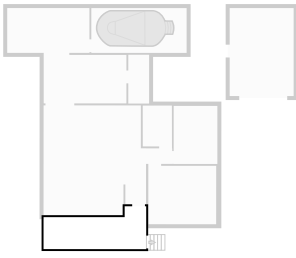

▼ Living Room  
Ground Floor

WIDTH: 5.17 m • LENGTH: 3.03 m  
AREA: 15.67 m<sup>2</sup> • PERIMETER: 16.40 m

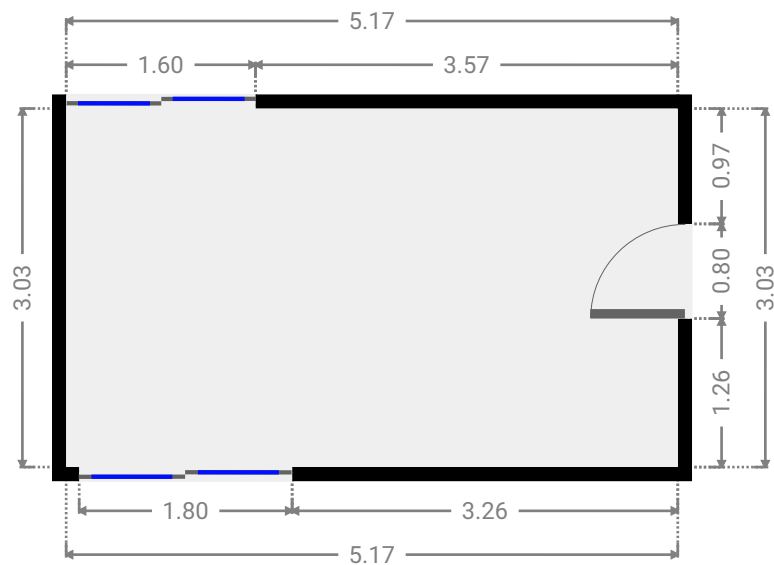

▼ **Spa Area**  
Ground Floor

WIDTH: 5.96 m • LENGTH: 2.80 m  
AREA: 16.68 m<sup>2</sup> • PERIMETER: 17.52 m

