

128 Upper Dawson Road

SUBMITTED BY
Ray White Rockhampton

CREATED ON
2022-11-09

Floors
1

▼ Ground Floor

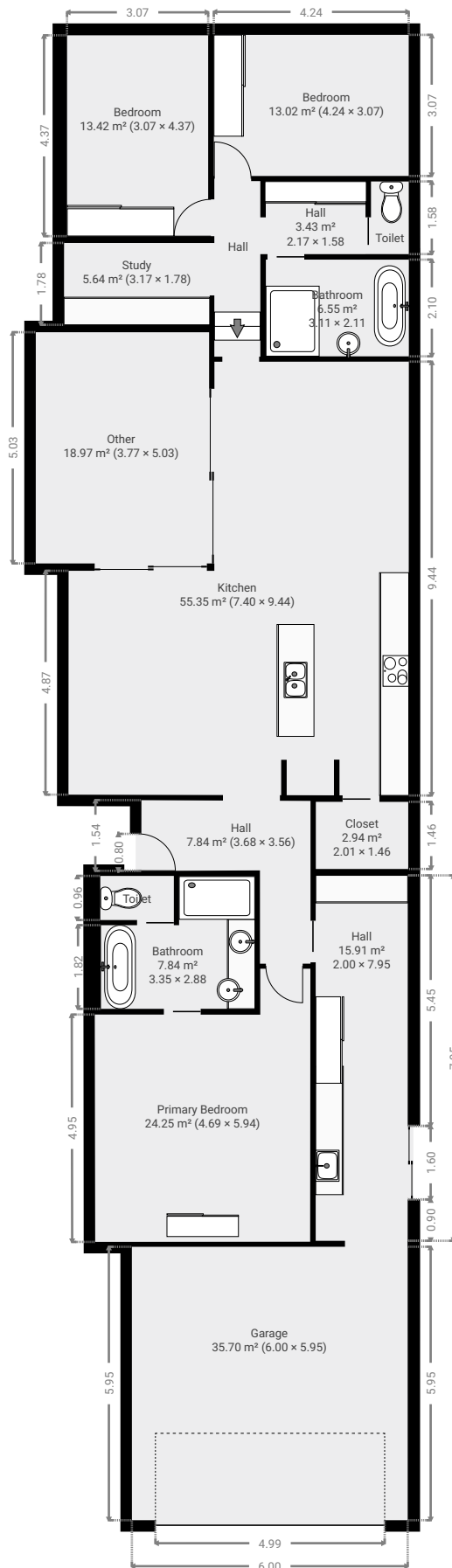

▼ **Bathroom**
Ground Floor

WIDTH: 3.35 m • LENGTH: 2.88 m
AREA: 7.84 m² • PERIMETER: 12.46 m

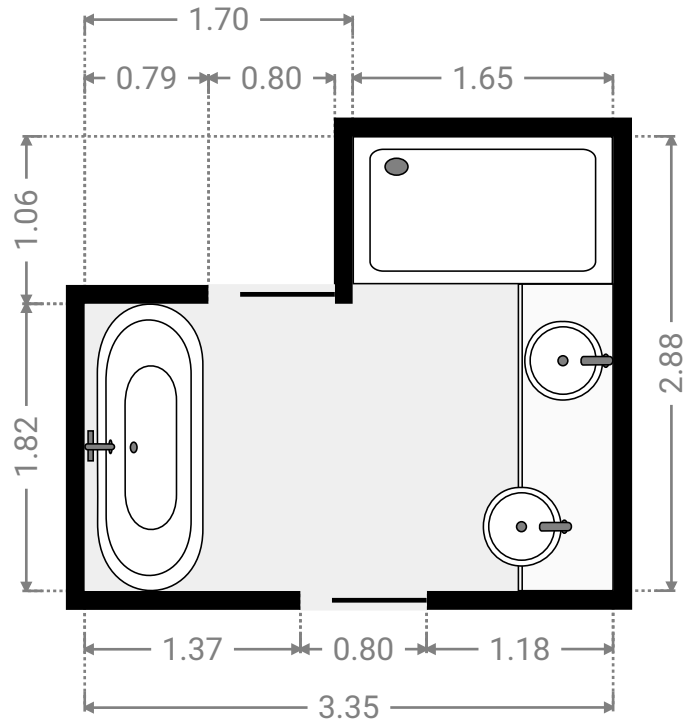
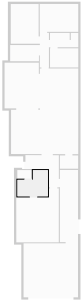

▼ **Bathroom**
Ground Floor

WIDTH: 3.11 m • LENGTH: 2.11 m
AREA: 6.55 m² • PERIMETER: 10.43 m

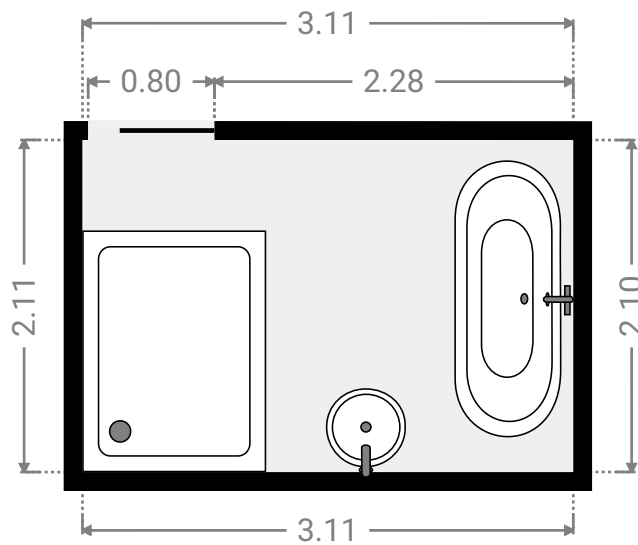

▼ **Bedroom**
Ground Floor

WIDTH: 3.07 m • LENGTH: 4.37 m
AREA: 13.42 m² • PERIMETER: 14.88 m

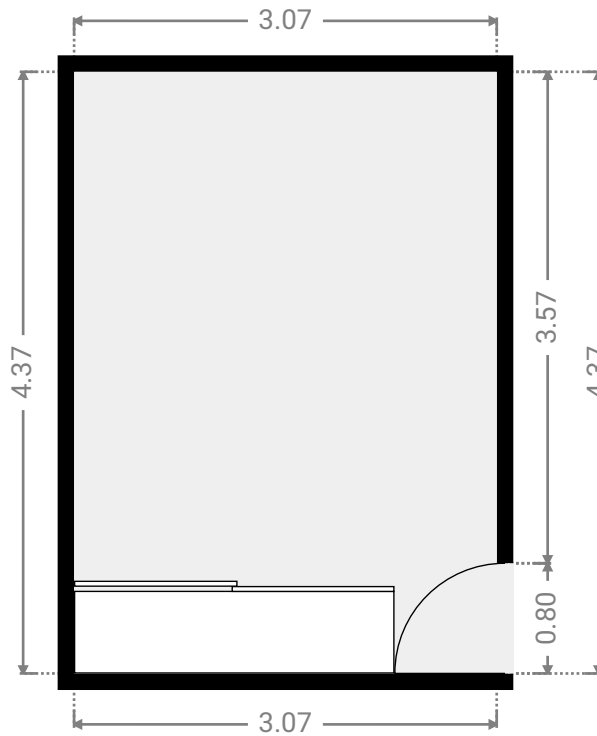
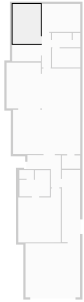

▼ **Bedroom**
Ground Floor

WIDTH: 4.24 m • LENGTH: 3.07 m
AREA: 13.02 m² • PERIMETER: 14.62 m

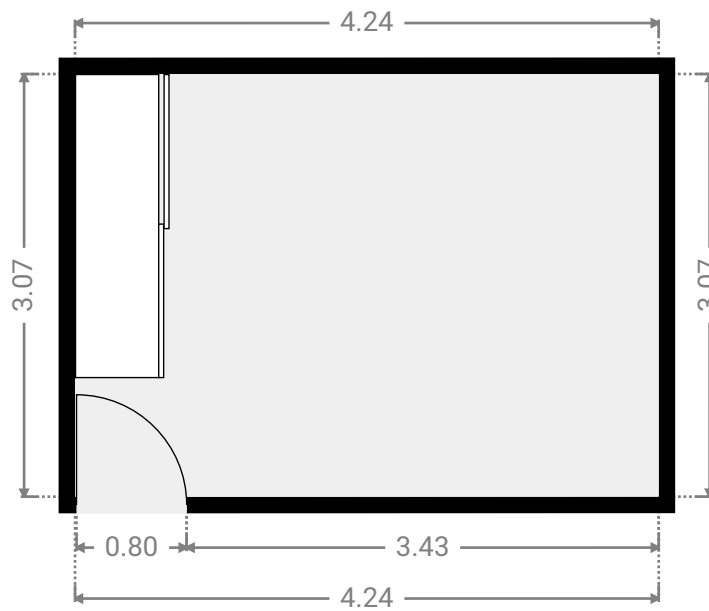
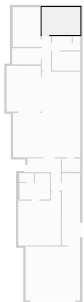

FLOORS: 1

▼ **Garage**
Ground Floor

WIDTH: 6.00 m • LENGTH: 5.95 m
AREA: 35.70 m² • PERIMETER: 23.90 m

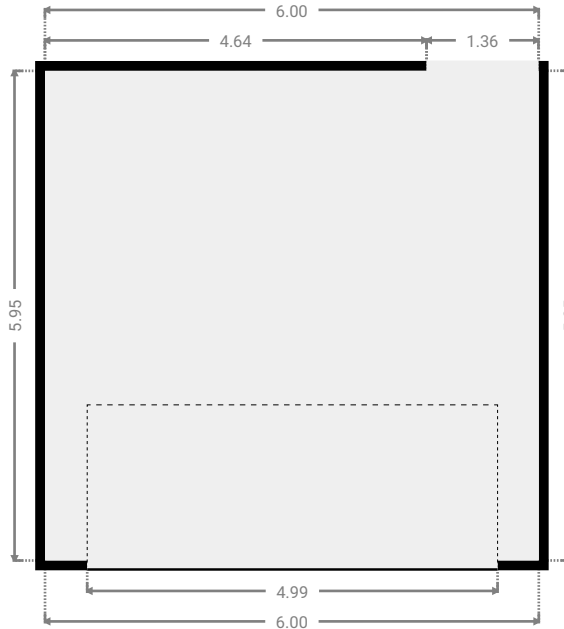
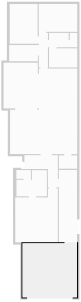

▼ **Hall**
Ground Floor

WIDTH: 2.00 m • LENGTH: 7.95 m
AREA: 15.91 m² • PERIMETER: 19.90 m

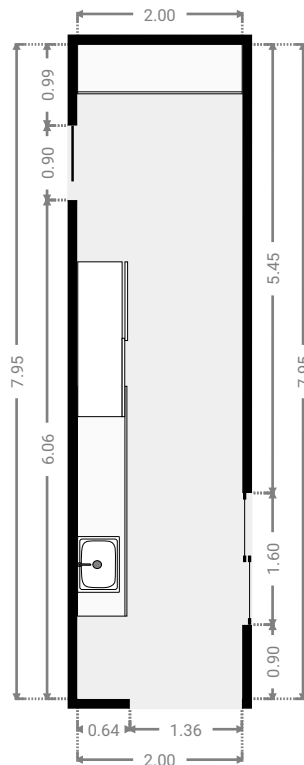

FLOORS: 1

▼ **Hall**
Ground Floor

WIDTH: 3.68 m • LENGTH: 3.56 m
AREA: 7.84 m² • PERIMETER: 14.47 m

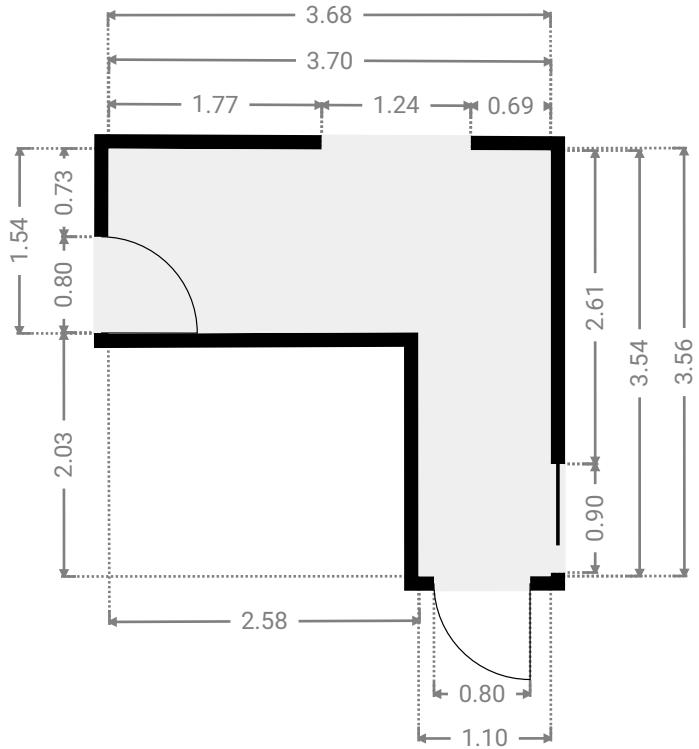

▼ **Hall**
Ground Floor

WIDTH: 1.00 m • LENGTH: 3.82 m
AREA: 3.82 m² • PERIMETER: 9.64 m

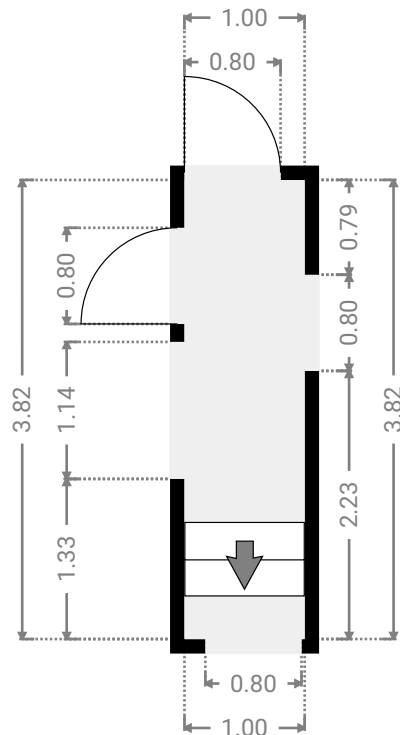

FLOORS: 1

▼ **Hall**
Ground Floor

WIDTH: 2.17 m • LENGTH: 1.58 m
AREA: 3.43 m² • PERIMETER: 7.50 m

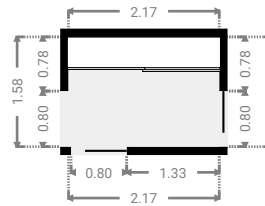

▼ **Kitchen**
Ground Floor

WIDTH: 7.40 m • LENGTH: 9.44 m
AREA: 55.35 m² • PERIMETER: 33.66 m

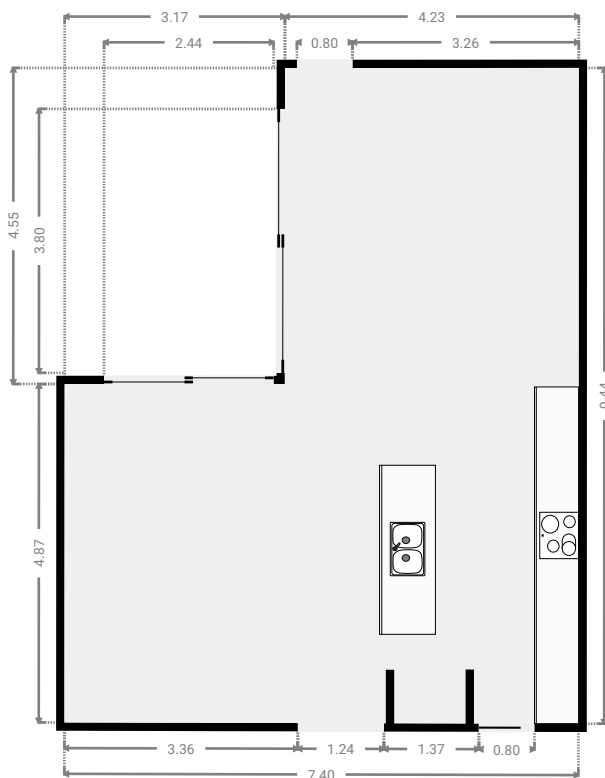
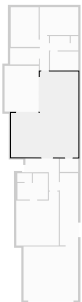

FLOORS: 1

▼ **Closet**
Ground Floor

WIDTH: 2.01 m • LENGTH: 1.46 m
AREA: 2.94 m² • PERIMETER: 6.94 m

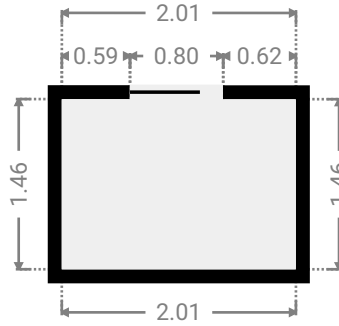

▼ **Other**
Ground Floor

WIDTH: 3.77 m • LENGTH: 5.03 m
AREA: 18.97 m² • PERIMETER: 17.60 m

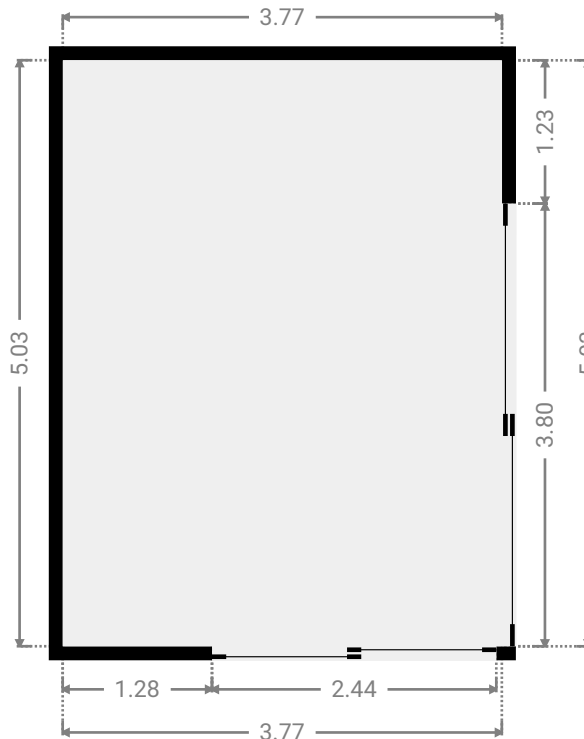

FLOORS: 1

▼ **Primary Bedroom**
Ground Floor

WIDTH: 4.69 m • LENGTH: 5.94 m
AREA: 24.25 m² • PERIMETER: 21.25 m

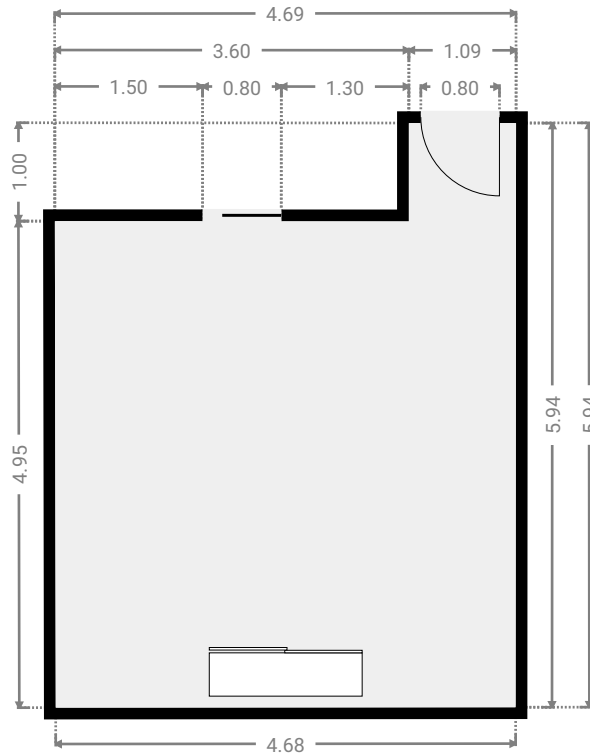
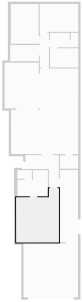

▼ **Study**
Ground Floor

WIDTH: 3.17 m • LENGTH: 1.78 m
AREA: 5.64 m² • PERIMETER: 9.90 m

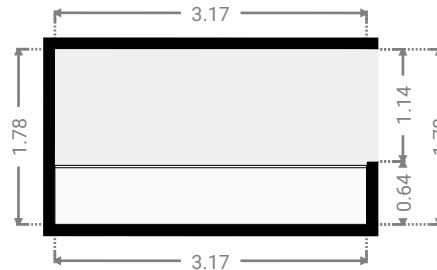

▼ **Toilet**
Ground Floor

WIDTH: 1.60 m • LENGTH: 0.96 m
AREA: 1.54 m² • PERIMETER: 5.12 m

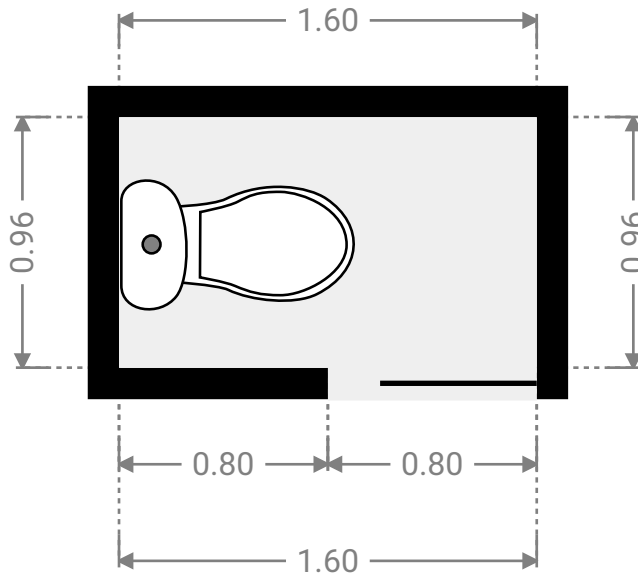
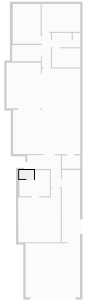

▼ **Toilet**
Ground Floor

WIDTH: 0.82 m • LENGTH: 1.58 m
AREA: 1.30 m² • PERIMETER: 4.80 m

