

# 127 Edington Street

**SUBMITTED BY**

Ray White Rockhampton Casey  
stockers@cqoz.com

---

**CREATED ON**

2021-11-30

---

**Floors**

2

---

▼ Ground Floor

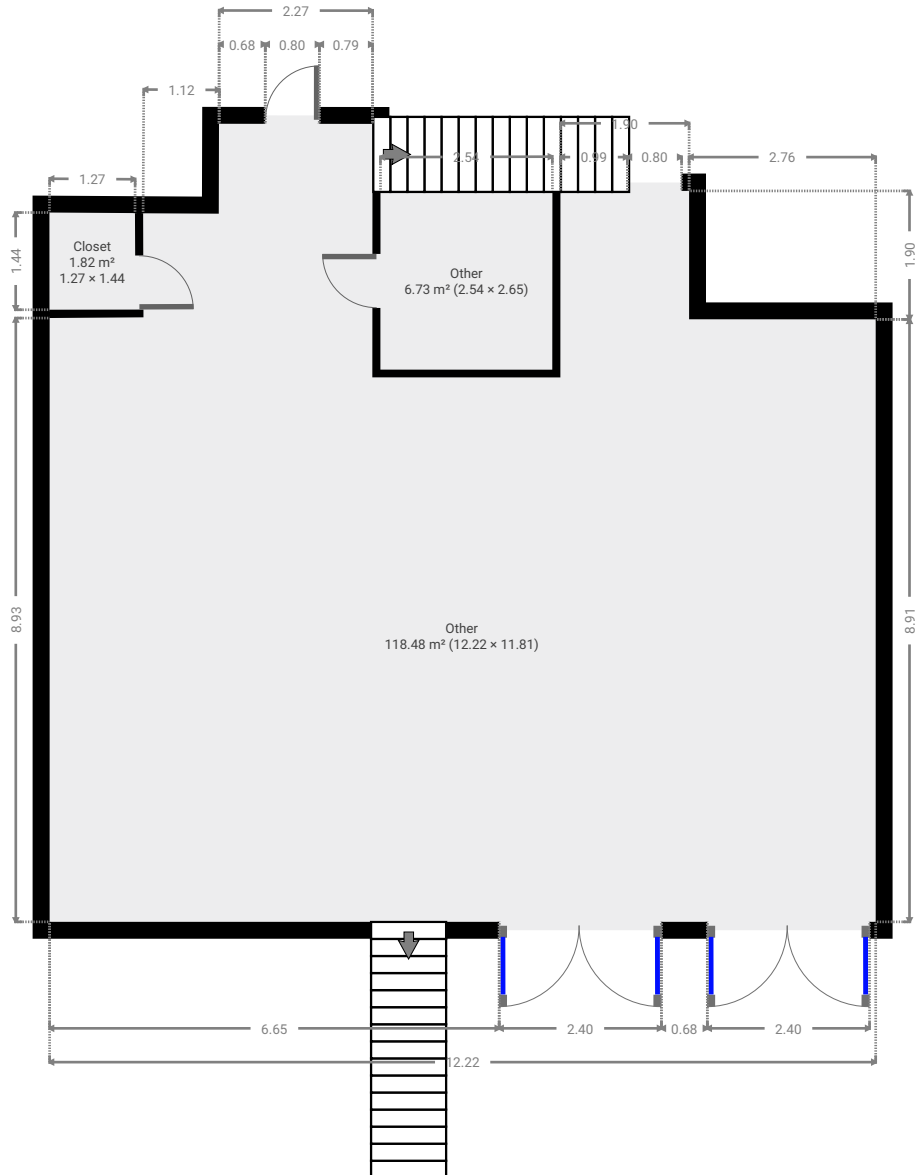
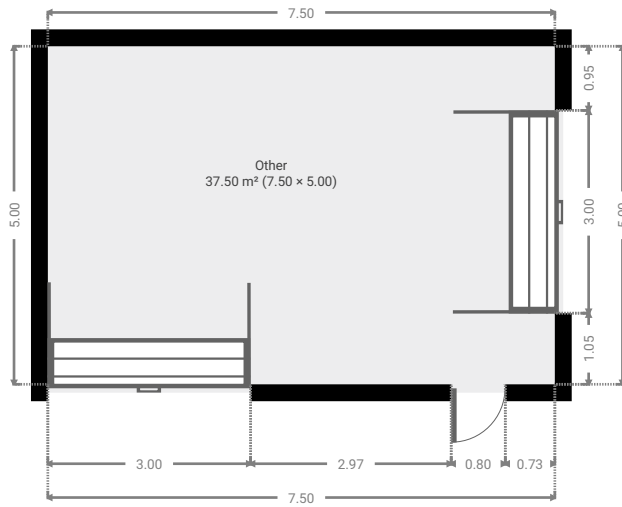

▼ Other  
Ground Floor

WIDTH: 12.22 m • LENGTH: 11.81 m  
AREA: 118.48 m<sup>2</sup> • PERIMETER: 53.57 m

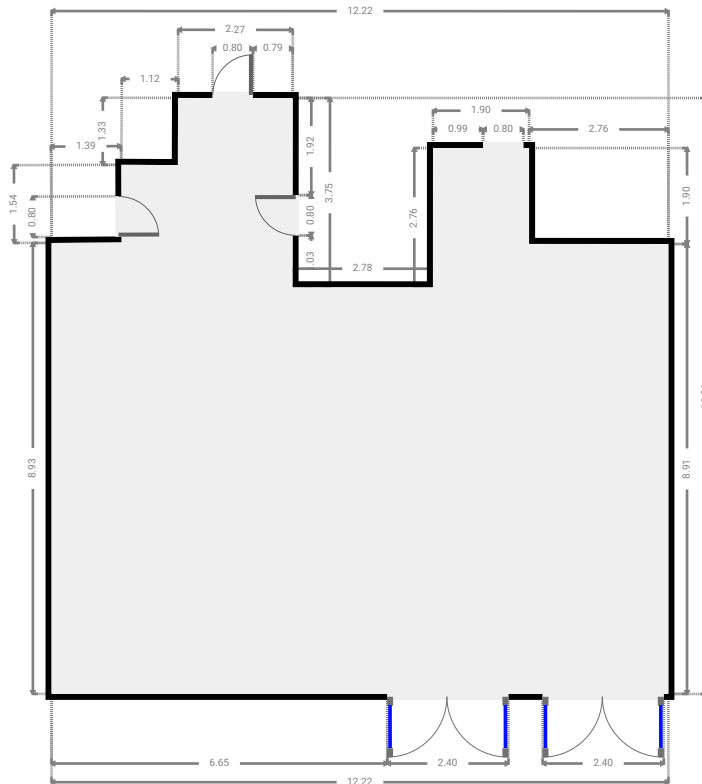
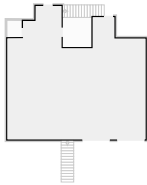

▼ Other  
Ground Floor

WIDTH: 2.54 m • LENGTH: 2.65 m  
AREA: 6.73 m<sup>2</sup> • PERIMETER: 10.38 m

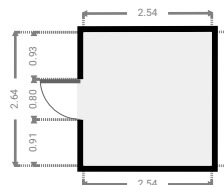
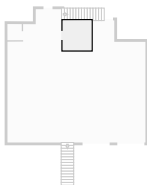

▼ **Closet**  
Ground Floor

WIDTH: 1.27 m • LENGTH: 1.44 m  
AREA: 1.82 m<sup>2</sup> • PERIMETER: 5.40 m

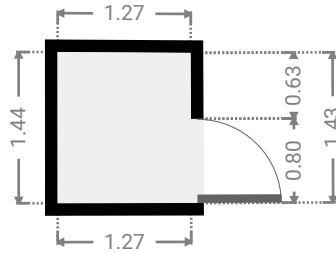
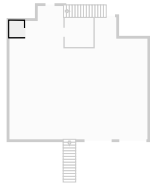

▼ **Other**  
Ground Floor

WIDTH: 7.50 m • LENGTH: 5.00 m  
AREA: 37.50 m<sup>2</sup> • PERIMETER: 25.00 m

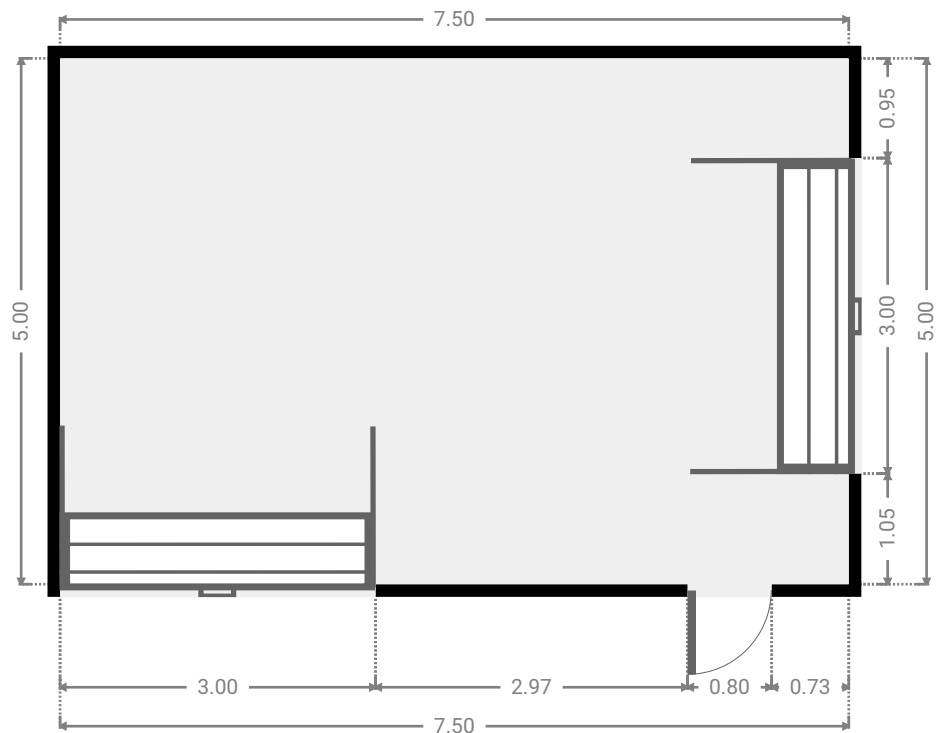
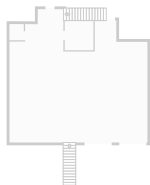

▼ 1st Floor

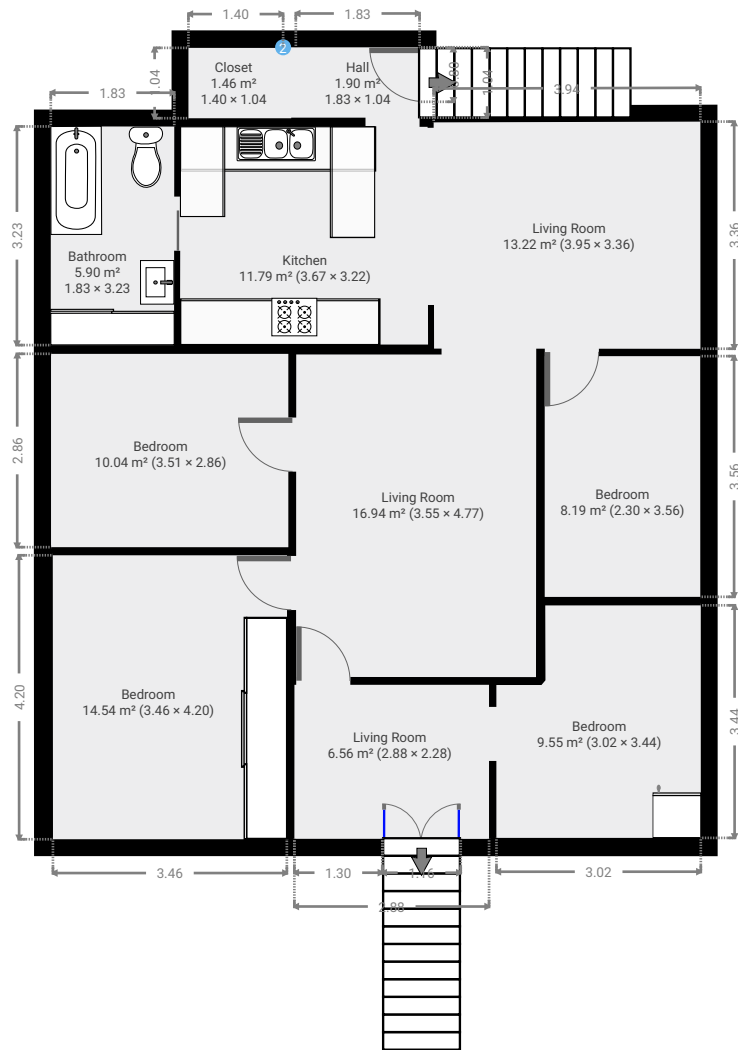

▼ **Living Room**  
1st Floor

WIDTH: 2.88 m • LENGTH: 2.28 m  
AREA: 6.56 m<sup>2</sup> • PERIMETER: 10.32 m

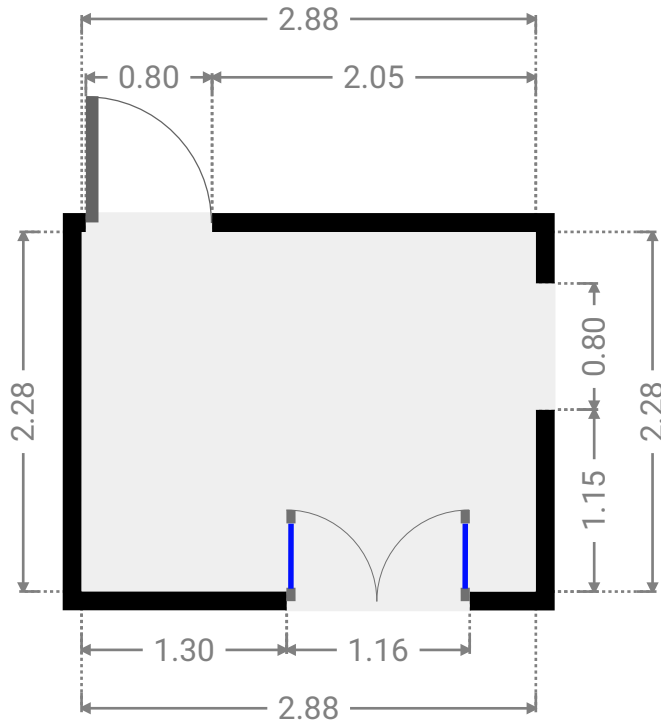
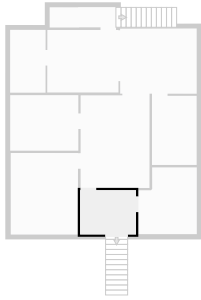

▼ **Bedroom**  
1st Floor

WIDTH: 3.02 m • LENGTH: 3.44 m  
AREA: 9.55 m<sup>2</sup> • PERIMETER: 12.89 m

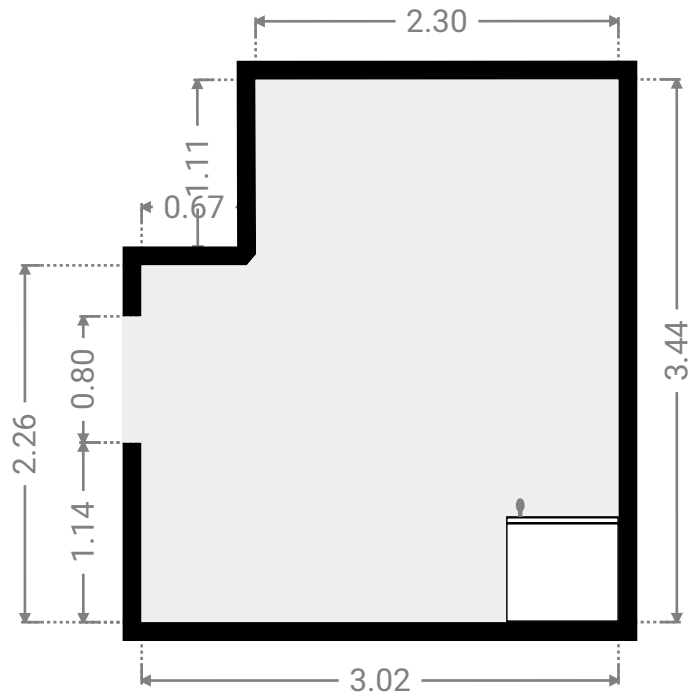
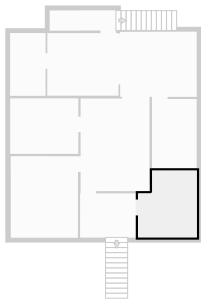

▼ Living Room  
1st Floor

WIDTH: 3.55 m • LENGTH: 4.77 m  
AREA: 16.94 m<sup>2</sup> • PERIMETER: 16.64 m

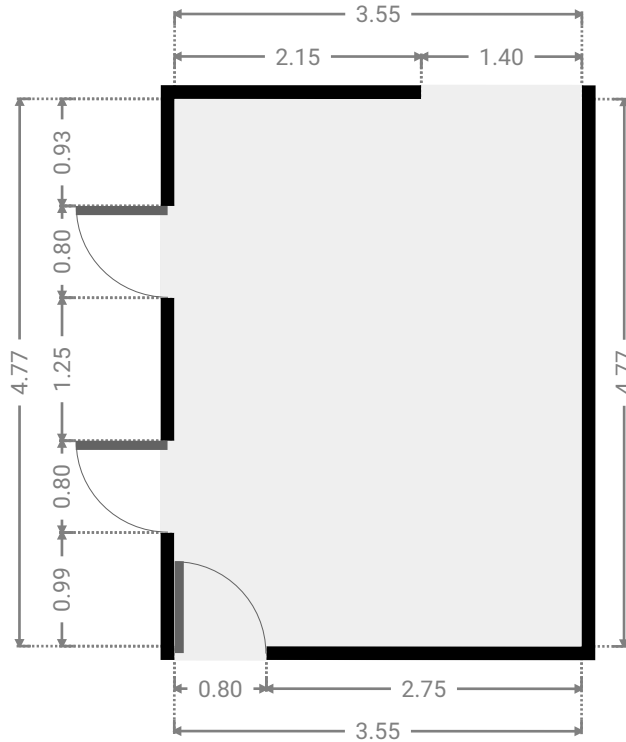
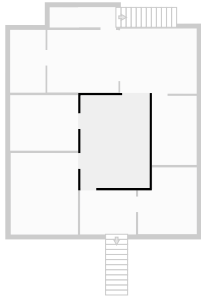

▼ Bedroom  
1st Floor

WIDTH: 3.46 m • LENGTH: 4.20 m  
AREA: 14.54 m<sup>2</sup> • PERIMETER: 15.32 m

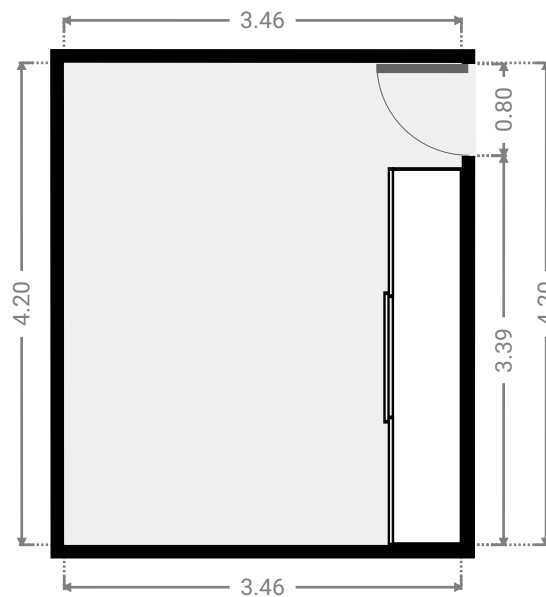
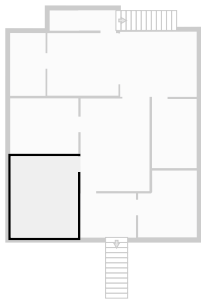

▼ **Bedroom**  
1st Floor

WIDTH: 3.51 m • LENGTH: 2.86 m  
AREA: 10.04 m<sup>2</sup> • PERIMETER: 12.74 m

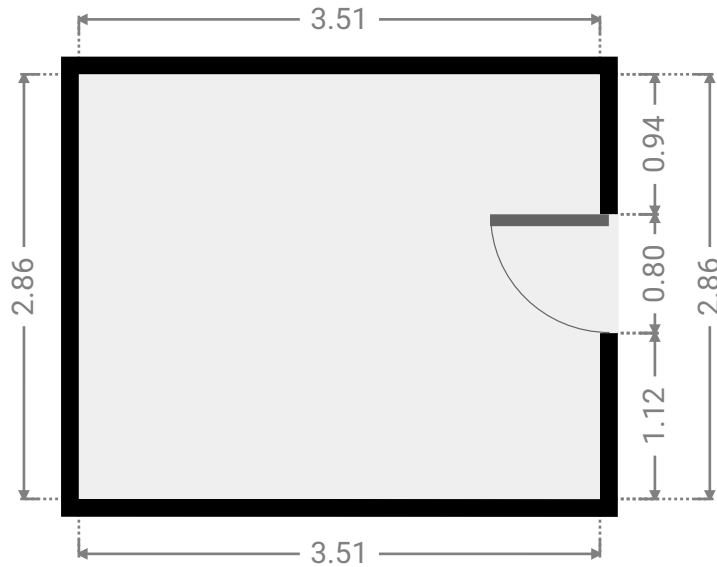
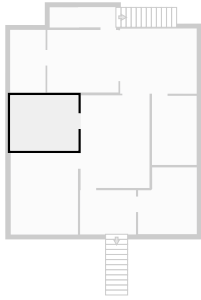

▼ **Bedroom**  
1st Floor

WIDTH: 2.30 m • LENGTH: 3.56 m  
AREA: 8.19 m<sup>2</sup> • PERIMETER: 11.72 m

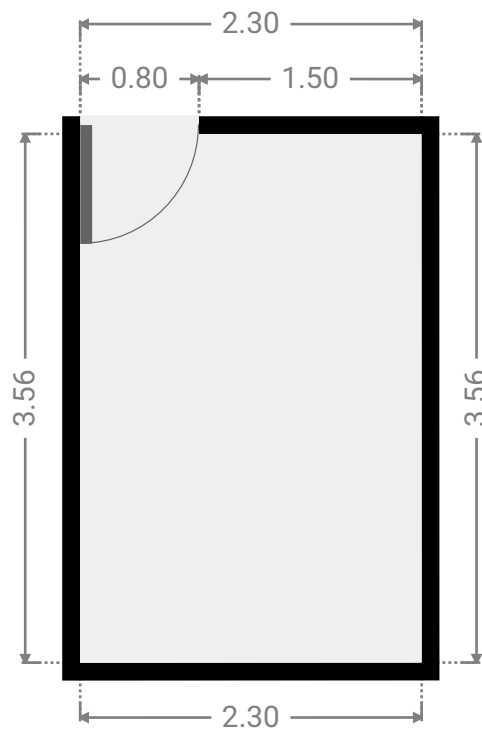
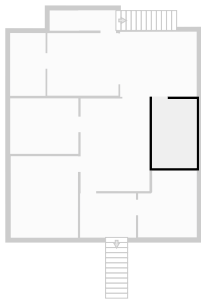



▼ **Living Room**  
1st Floor

WIDTH: 3.95 m • LENGTH: 3.36 m  
AREA: 13.22 m<sup>2</sup> • PERIMETER: 14.59 m

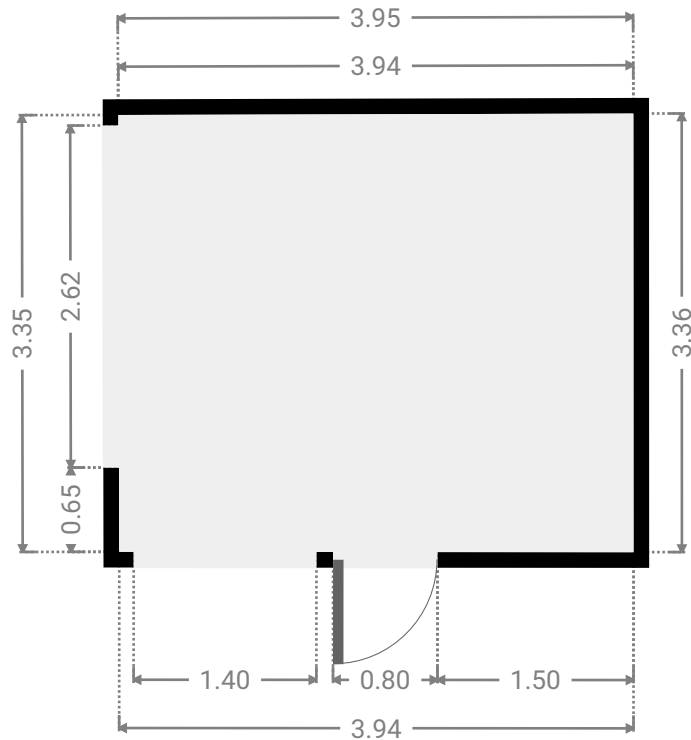
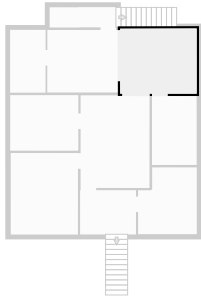

▼ **Kitchen**  
1st Floor

WIDTH: 3.67 m • LENGTH: 3.22 m  
AREA: 11.79 m<sup>2</sup> • PERIMETER: 13.77 m

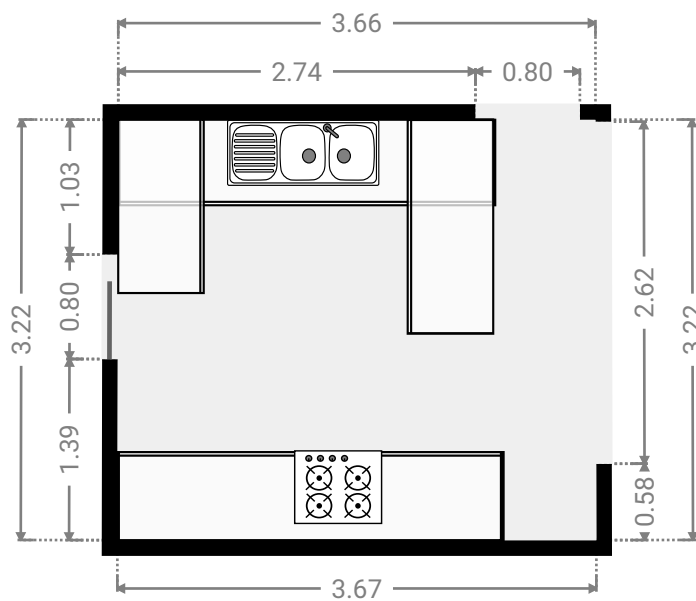
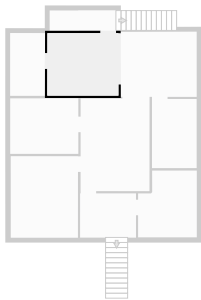

▼ **Bathroom**  
1st Floor

WIDTH: 1.83 m • LENGTH: 3.23 m  
AREA: 5.90 m<sup>2</sup> • PERIMETER: 10.12 m

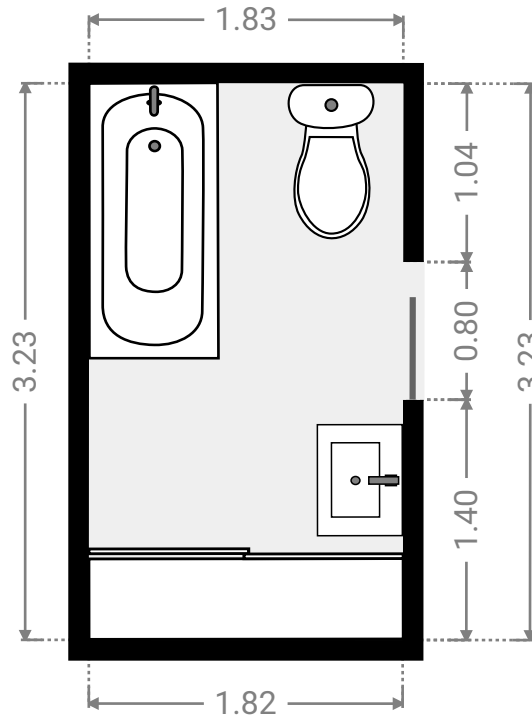
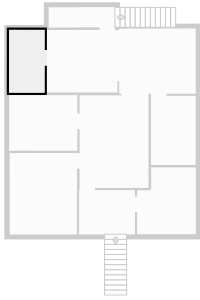

▼ **Hall**  
1st Floor

WIDTH: 1.83 m • LENGTH: 1.04 m  
AREA: 1.90 m<sup>2</sup> • PERIMETER: 5.74 m

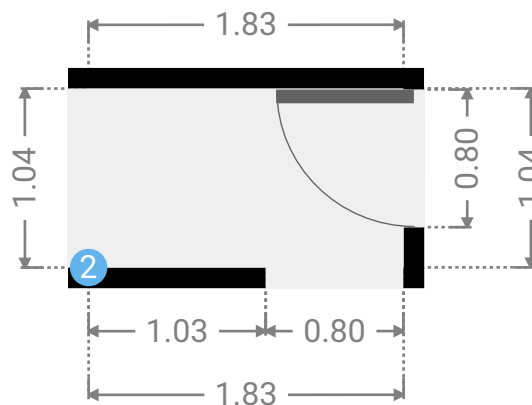
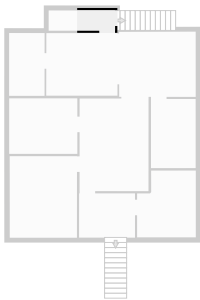

▼ **Closet**  
1st Floor

WIDTH: 1.40 m • LENGTH: 1.04 m  
AREA: 1.46 m<sup>2</sup> • PERIMETER: 4.88 m

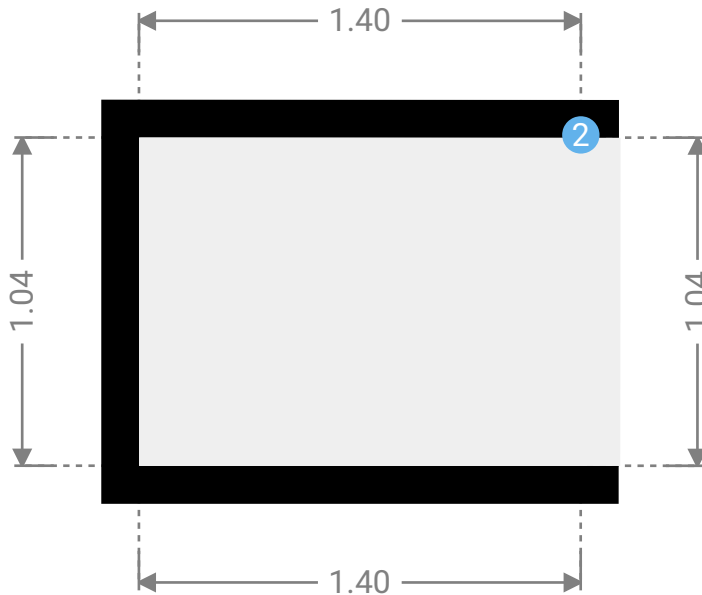
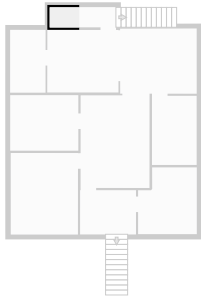

▼ **Closet/1st Floor**

**2** OPENING

Height  
0.00 m

