

125 Edington Street

Created on
2021-09-30

Floors
2

▼ Ground Floor

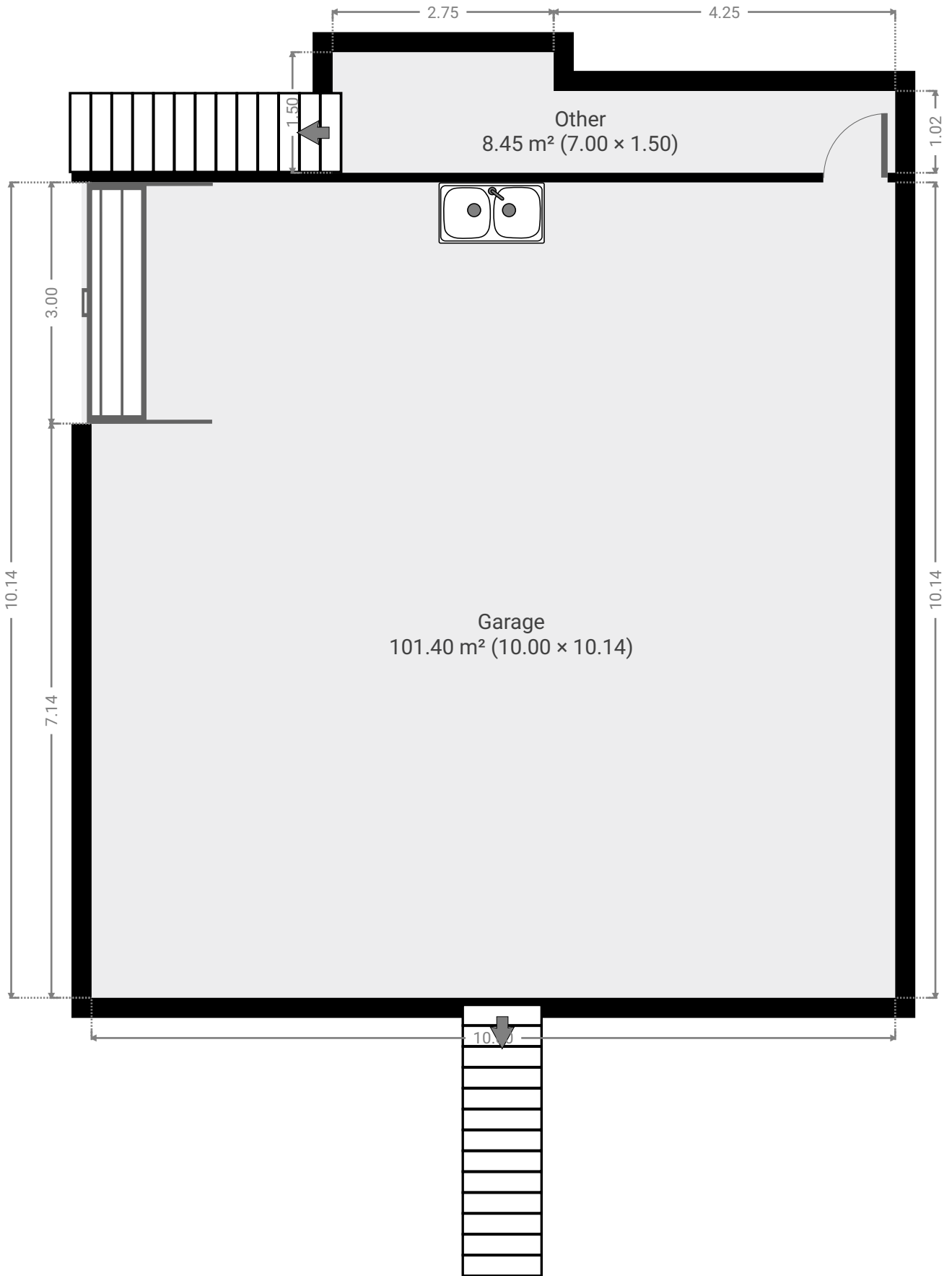

▼ **Garage**
Ground Floor

WIDTH: 10.00 m • LENGTH: 10.14 m
AREA: 101.40 m² • PERIMETER: 40.28 m

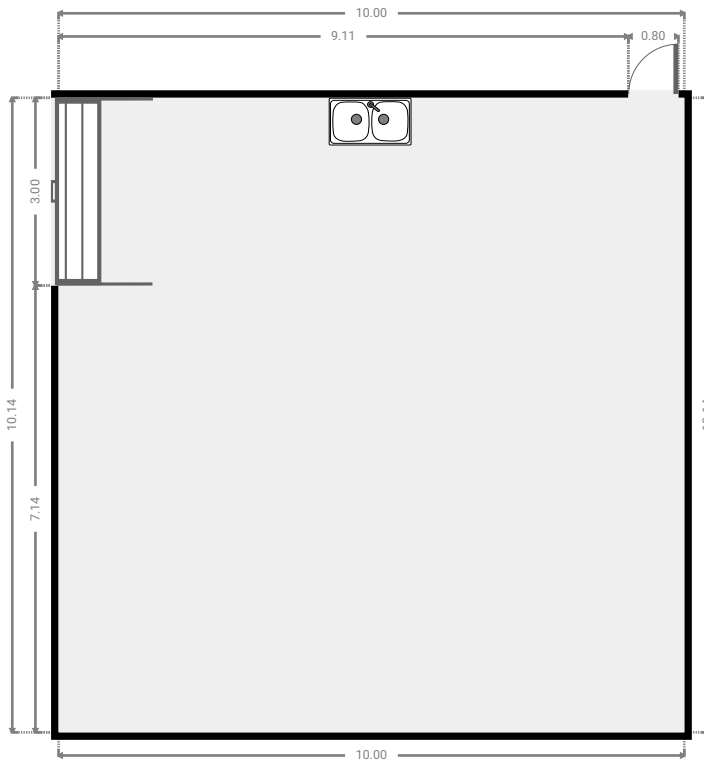
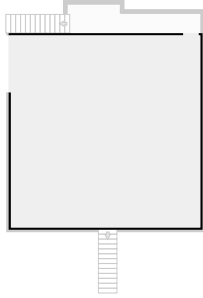

▼ **Other**
Ground Floor

WIDTH: 7.00 m • LENGTH: 1.50 m
AREA: 8.45 m² • PERIMETER: 17.00 m

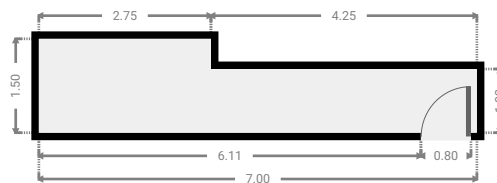
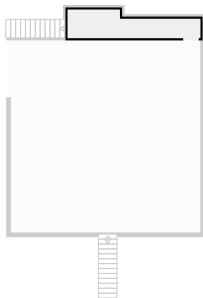

▼ 1st Floor

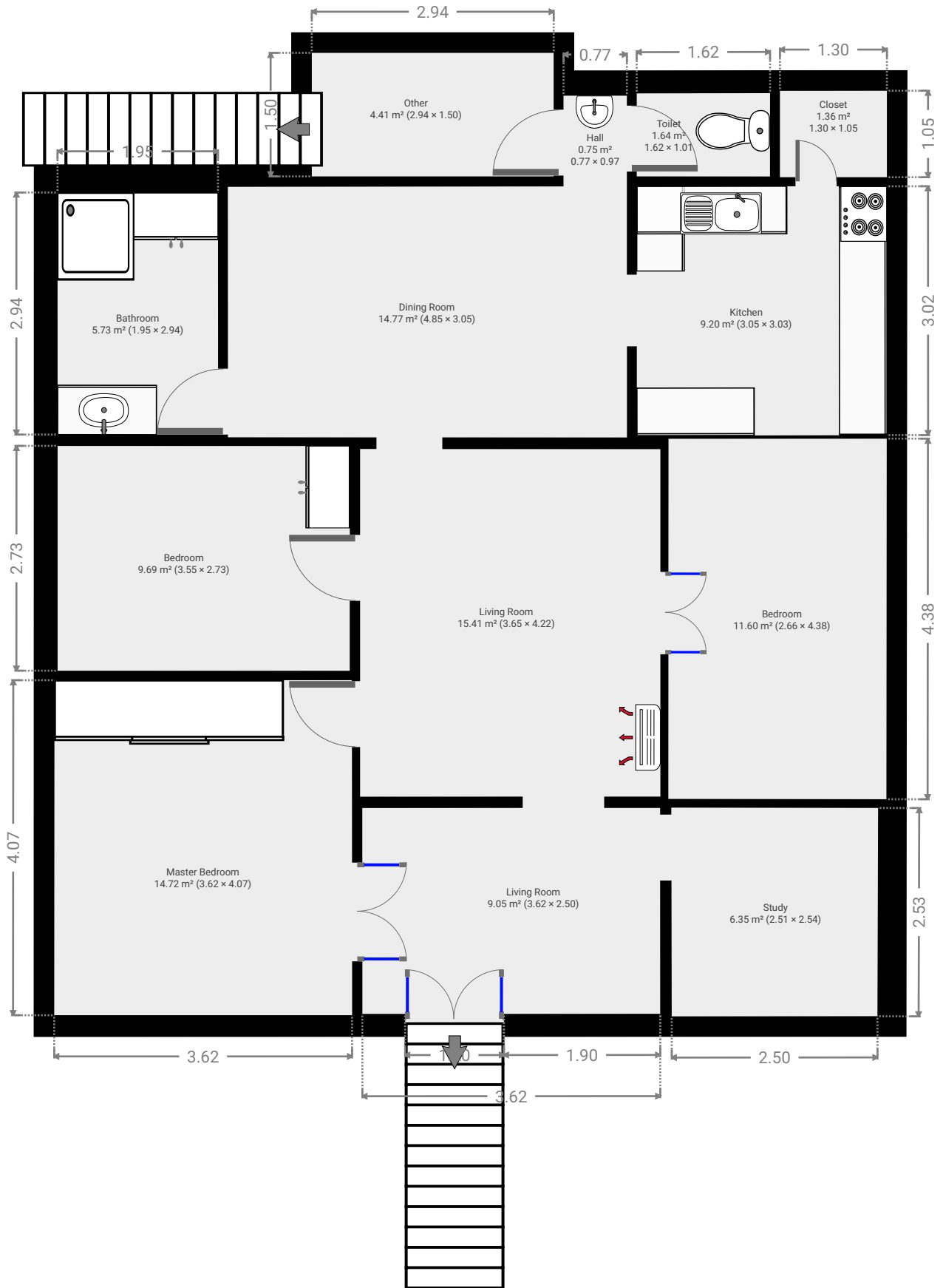

▼ **Living Room**
1st Floor

WIDTH: 3.62 m • LENGTH: 2.50 m
AREA: 9.05 m² • PERIMETER: 12.24 m

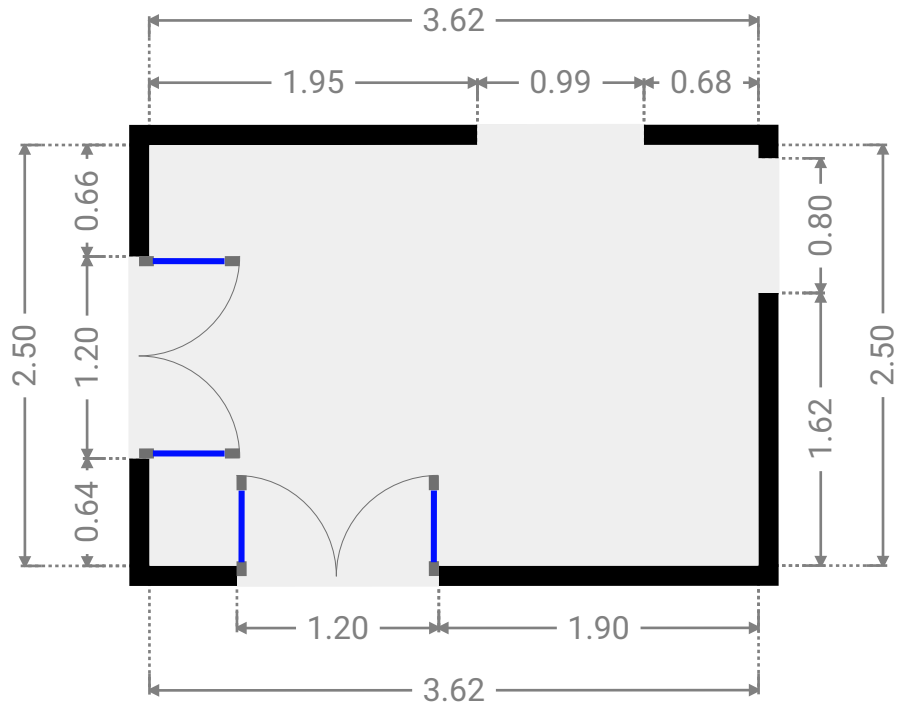
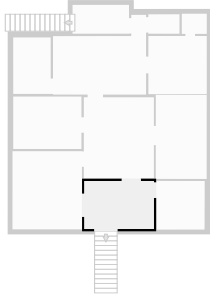

▼ **Study**
1st Floor

WIDTH: 2.51 m • LENGTH: 2.54 m
AREA: 6.35 m² • PERIMETER: 10.08 m

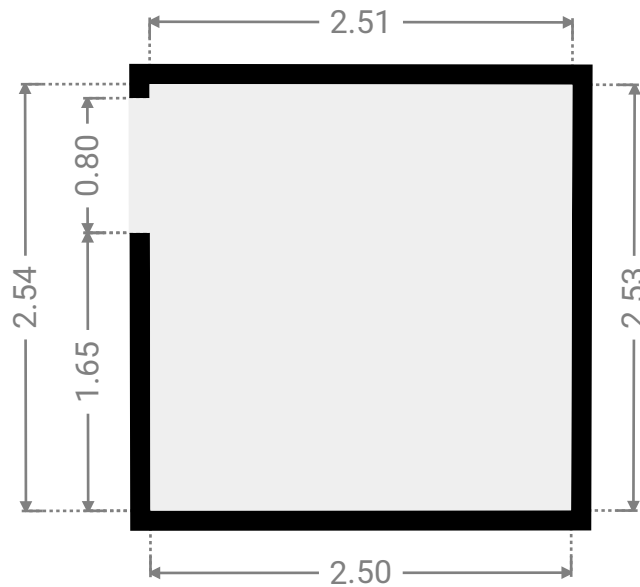
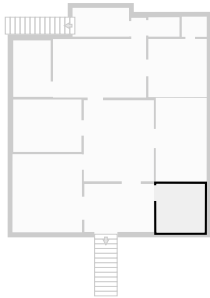

▼ Living Room
1st Floor

WIDTH: 3.65 m • LENGTH: 4.22 m
AREA: 15.41 m² • PERIMETER: 15.74 m

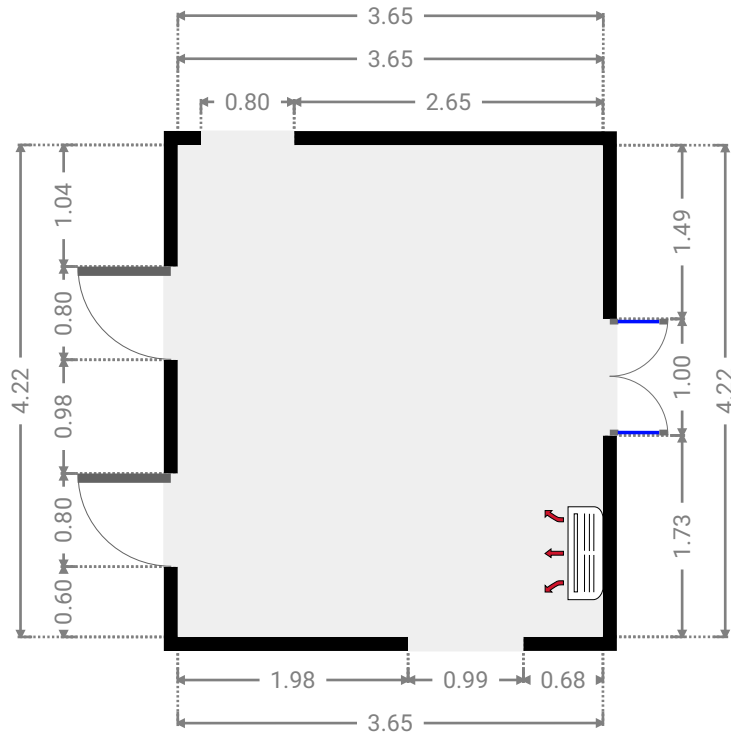
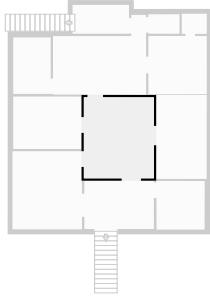

▼ Bedroom
1st Floor

WIDTH: 2.66 m • LENGTH: 4.38 m
AREA: 11.60 m² • PERIMETER: 14.06 m

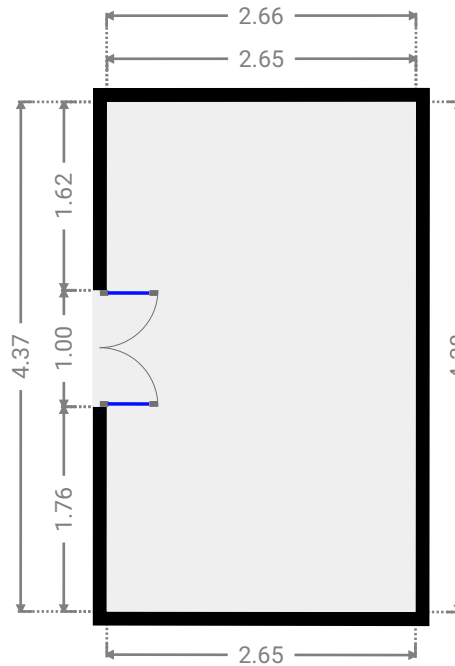
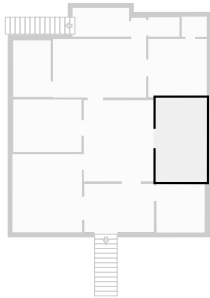

▼ **Master Bedroom**
1st Floor

WIDTH: 3.62 m • LENGTH: 4.07 m
AREA: 14.72 m² • PERIMETER: 15.37 m

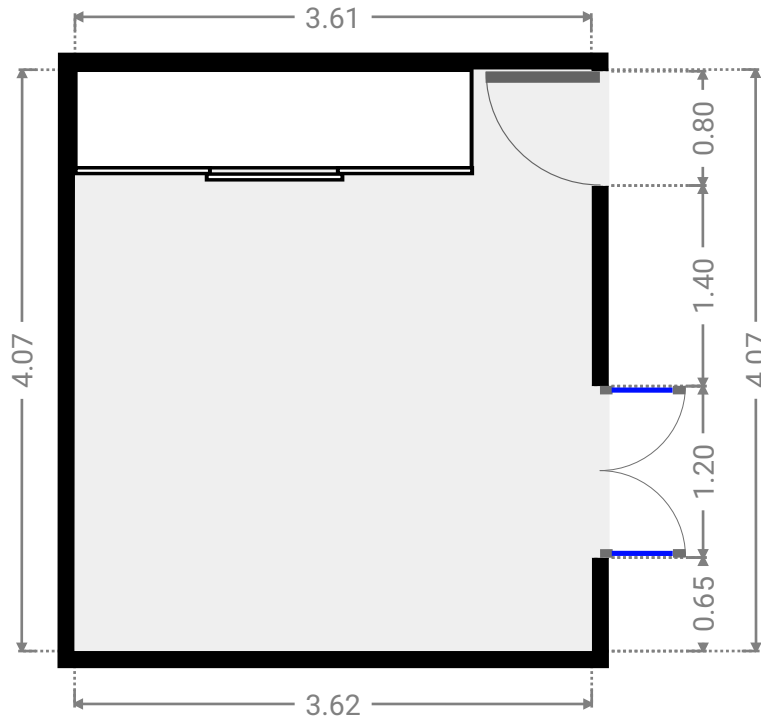
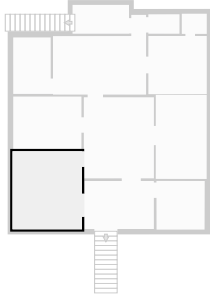

▼ **Bedroom**
1st Floor

WIDTH: 3.55 m • LENGTH: 2.73 m
AREA: 9.69 m² • PERIMETER: 12.56 m

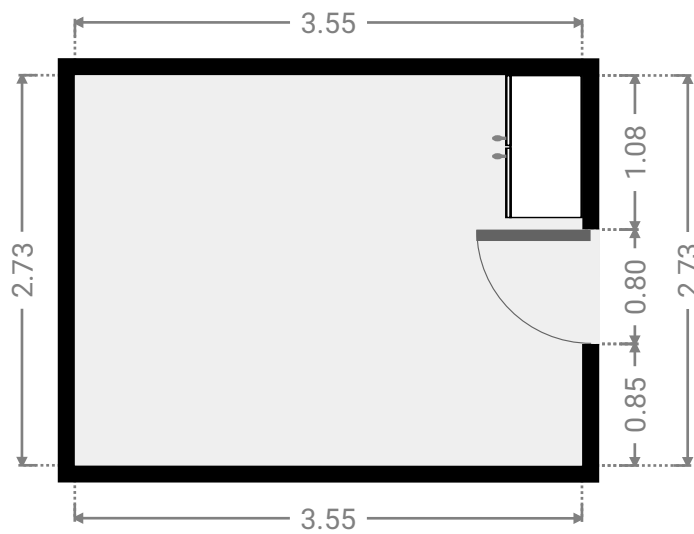
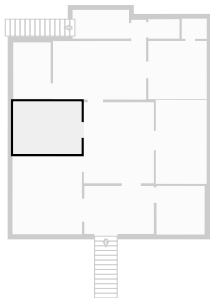

▼ **Bathroom**
1st Floor

WIDTH: 1.95 m • LENGTH: 2.94 m
AREA: 5.73 m² • PERIMETER: 9.78 m

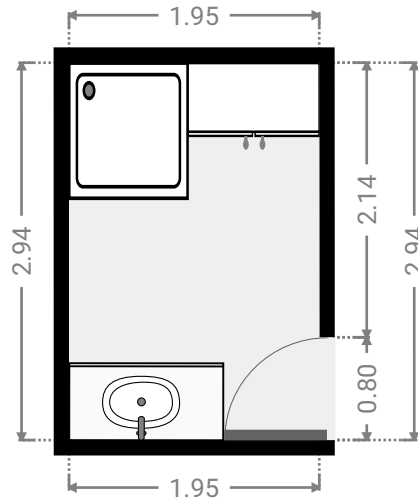
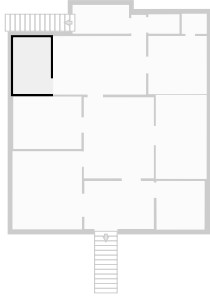

▼ **Dining Room**
1st Floor

WIDTH: 4.85 m • LENGTH: 3.05 m
AREA: 14.77 m² • PERIMETER: 15.79 m

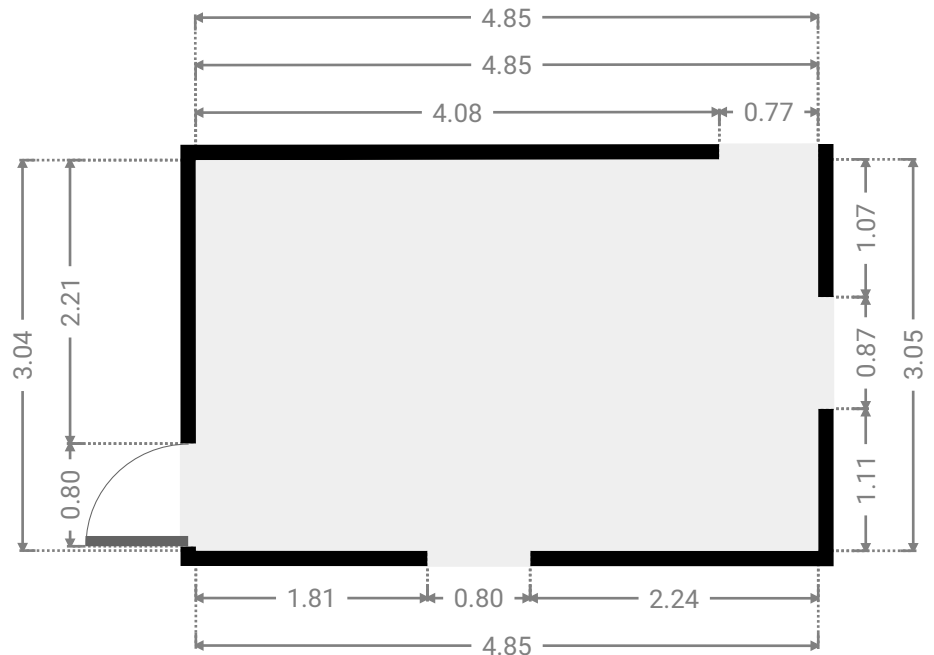
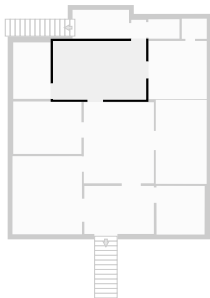

▼ Kitchen
1st Floor

WIDTH: 3.05 m • LENGTH: 3.03 m
AREA: 9.20 m² • PERIMETER: 12.13 m

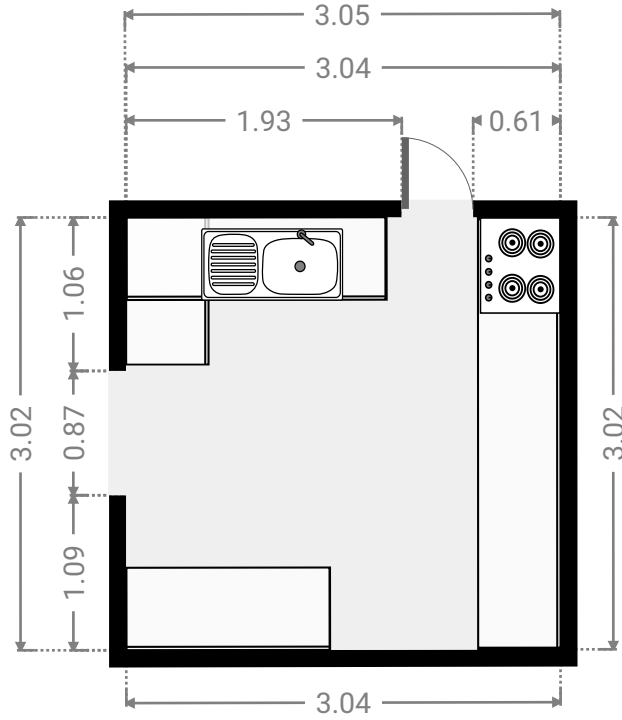
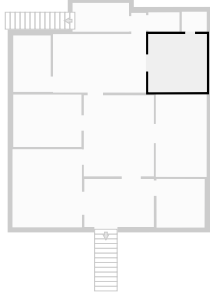

▼ Closet
1st Floor

WIDTH: 1.30 m • LENGTH: 1.05 m
AREA: 1.36 m² • PERIMETER: 4.70 m

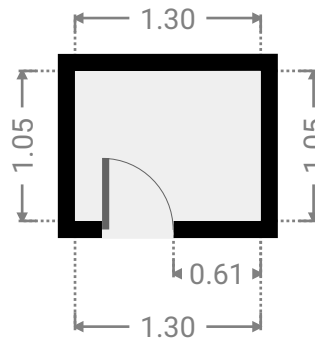

▼ **Hall**
1st Floor

WIDTH: 0.77 m • LENGTH: 0.97 m
AREA: 0.75 m² • PERIMETER: 3.48 m

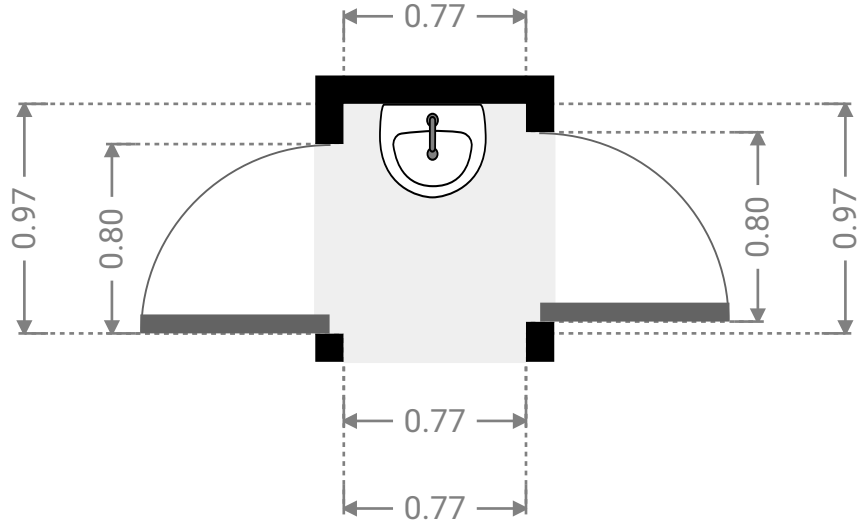
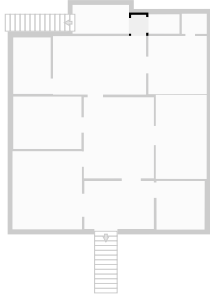

▼ **Toilet**
1st Floor

WIDTH: 1.62 m • LENGTH: 1.01 m
AREA: 1.64 m² • PERIMETER: 5.26 m

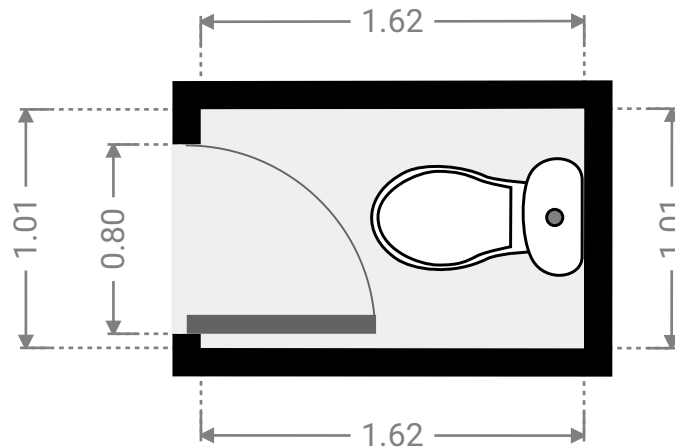

▼ Other
1st Floor

WIDTH: 2.94 m • LENGTH: 1.50 m
AREA: 4.41 m² • PERIMETER: 8.88 m

