

124 Constance Avenue

Created on
2021-09-23

Floors
1

▼ Ground Floor

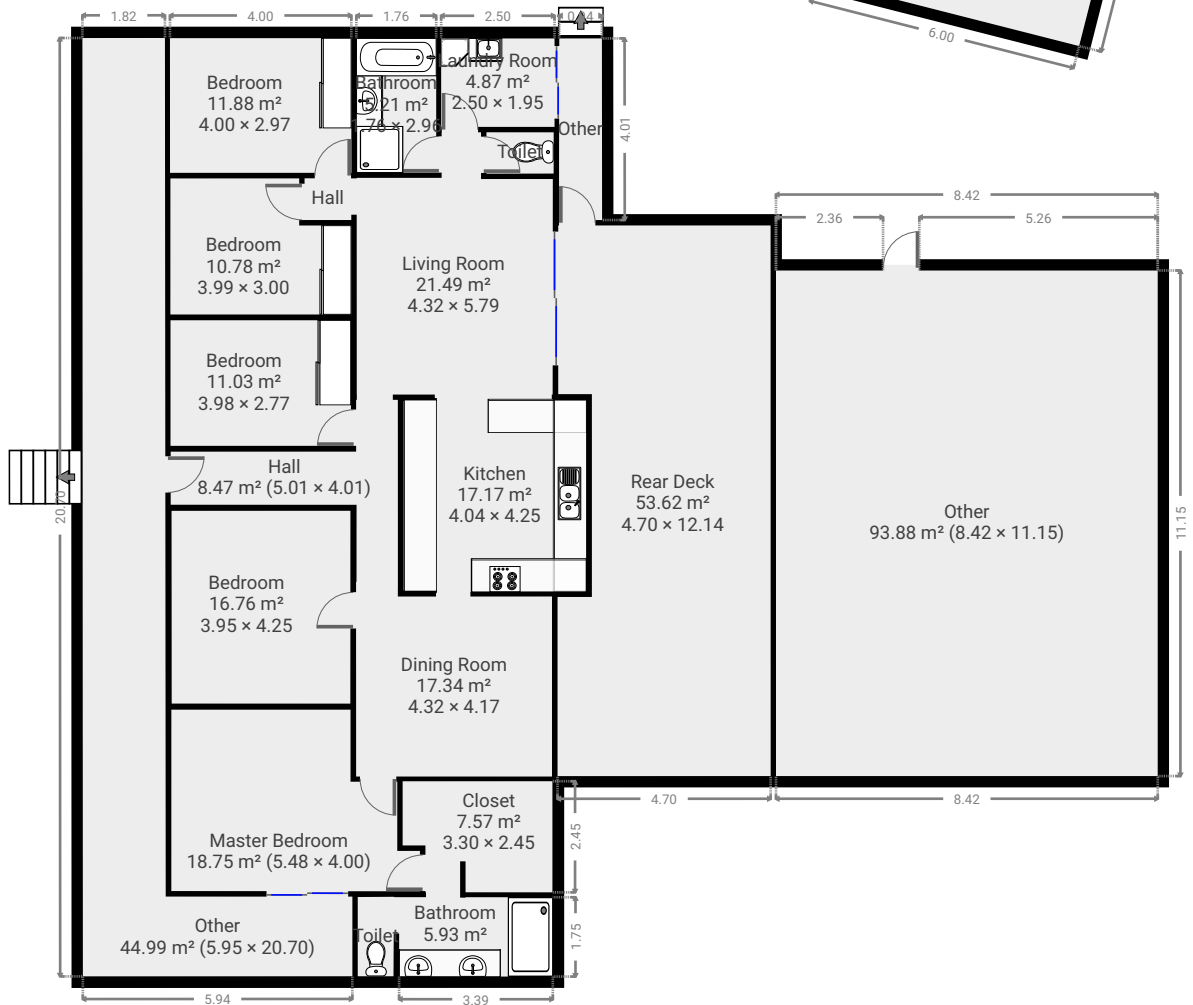
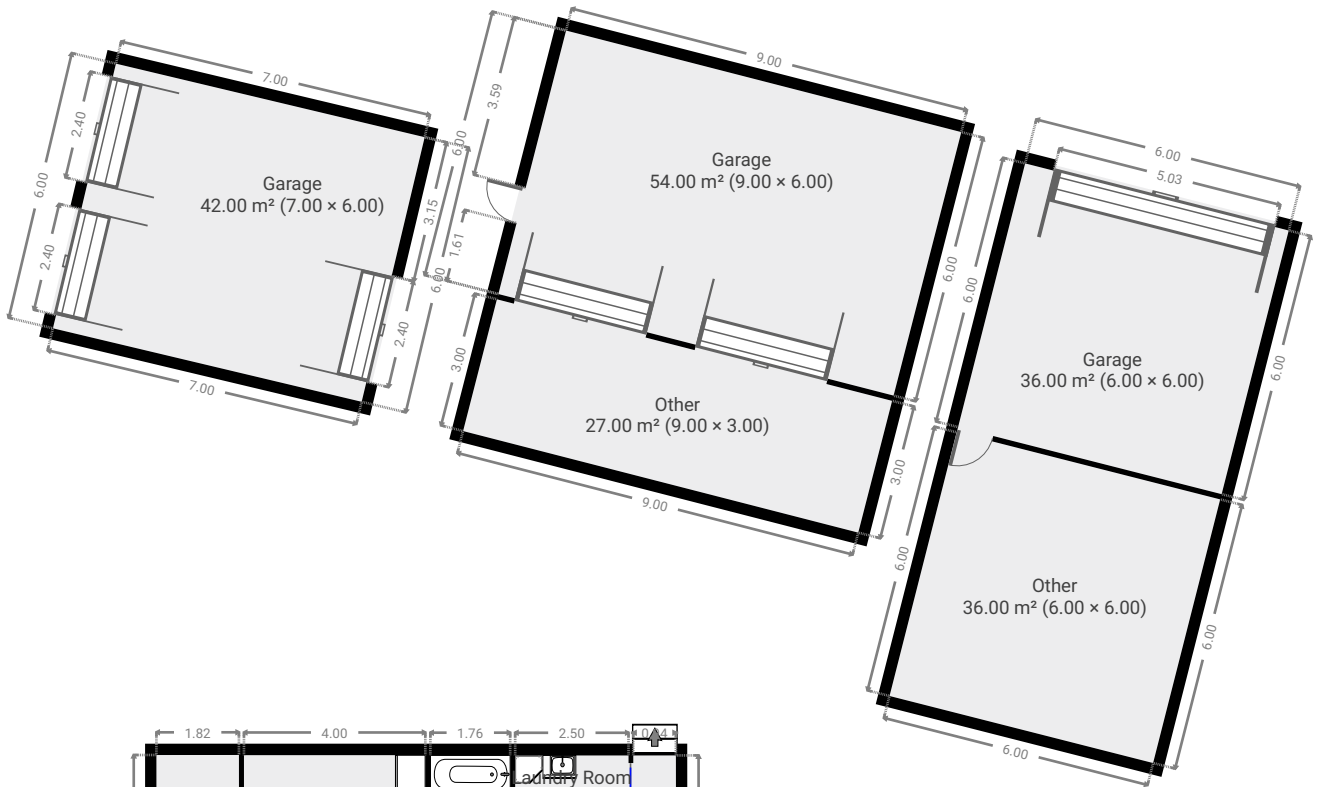

▼ **Master Bedroom**
Ground Floor

WIDTH: 4.00 m • LENGTH: 5.48 m
AREA: 18.75 m² • PERIMETER: 18.97 m

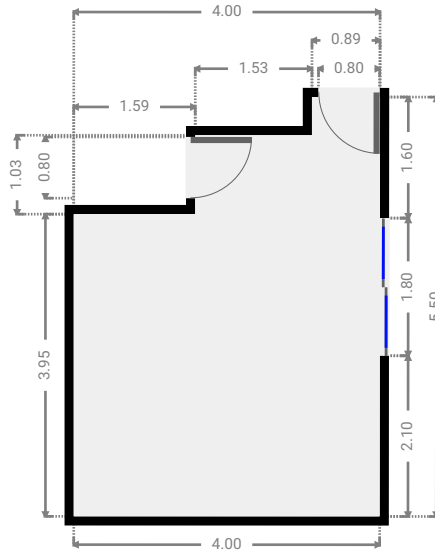
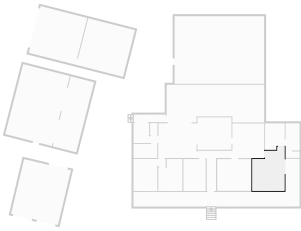

▼ **Garage**
Ground Floor

WIDTH: 6.00 m • LENGTH: 7.00 m
AREA: 42.00 m² • PERIMETER: 26.00 m

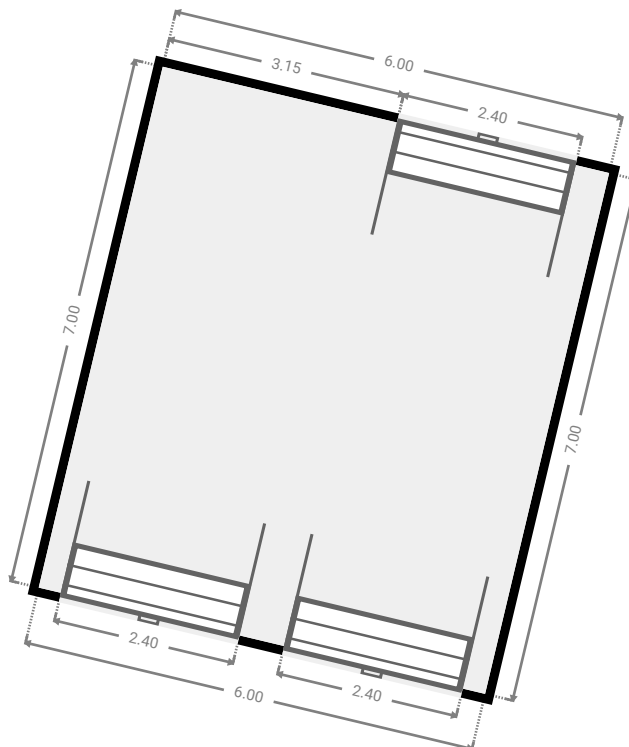
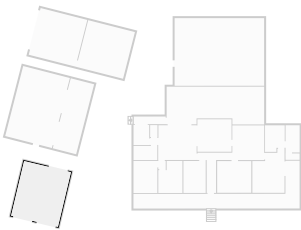

▼ **Garage**
Ground Floor

WIDTH: 6.00 m • LENGTH: 9.00 m
AREA: 54.00 m² • PERIMETER: 30.00 m

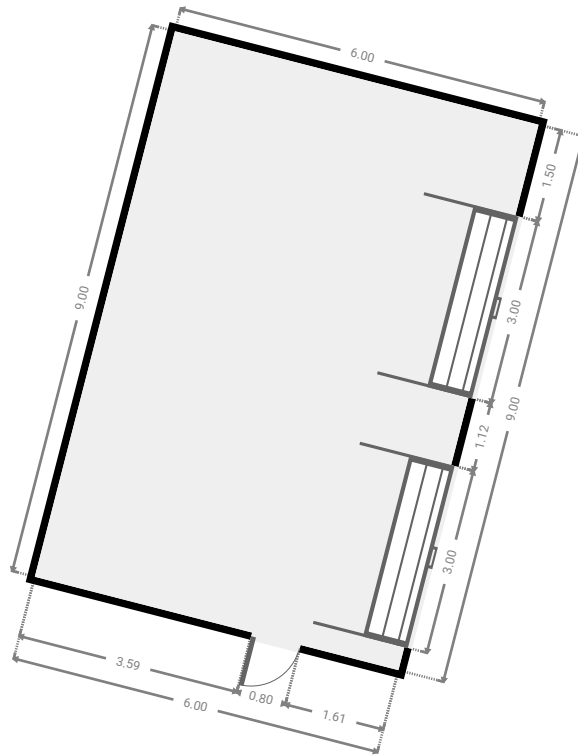
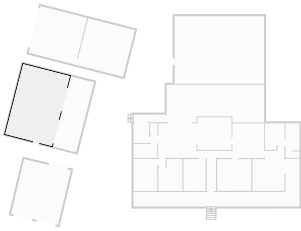

▼ **Other**
Ground Floor

WIDTH: 3.00 m • LENGTH: 9.00 m
AREA: 27.00 m² • PERIMETER: 24.00 m

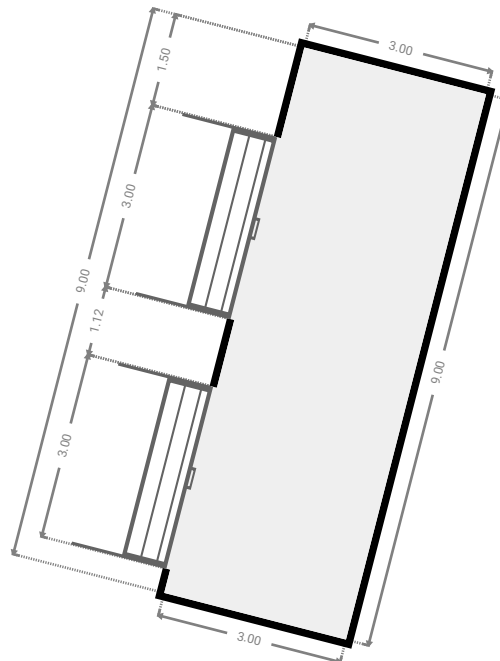
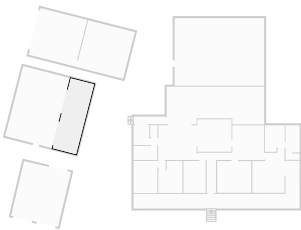

▼ **Garage**
Ground Floor

WIDTH: 6.00 m • LENGTH: 6.00 m
AREA: 36.00 m² • PERIMETER: 24.00 m

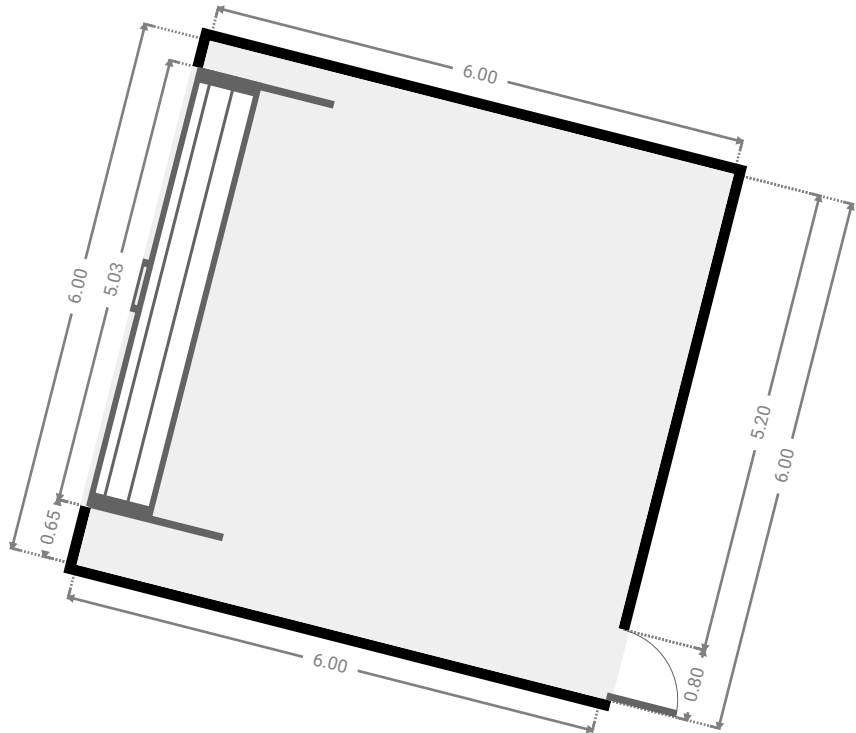
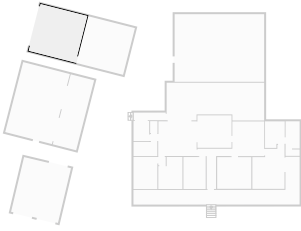

▼ **Other**
Ground Floor

WIDTH: 6.00 m • LENGTH: 6.00 m
AREA: 36.00 m² • PERIMETER: 24.00 m

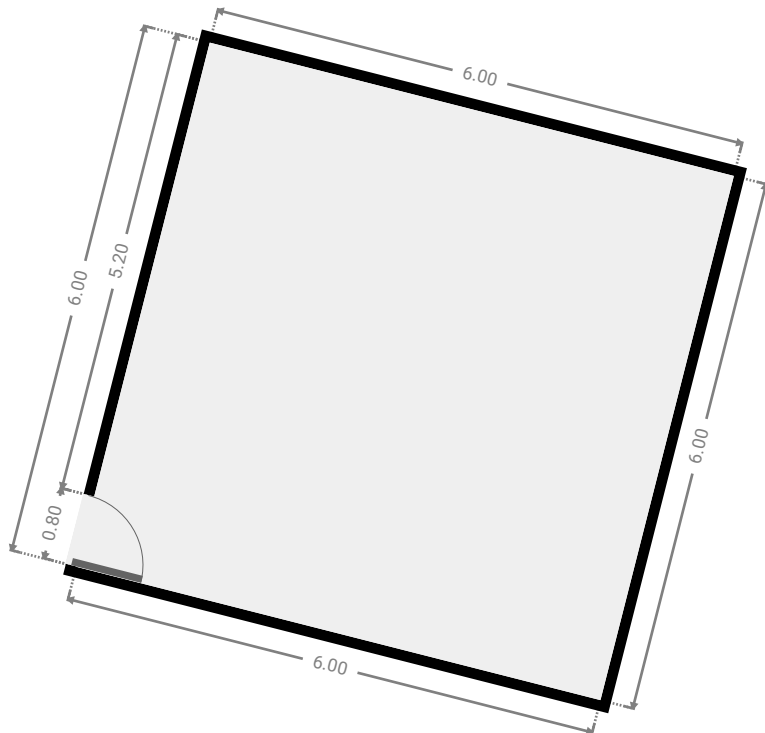
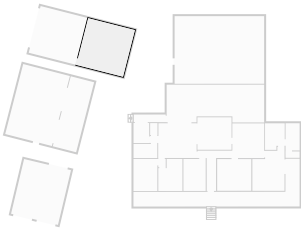

▼ Other
Ground Floor

WIDTH: 11.15 m • LENGTH: 8.42 m
AREA: 93.88 m² • PERIMETER: 39.14 m

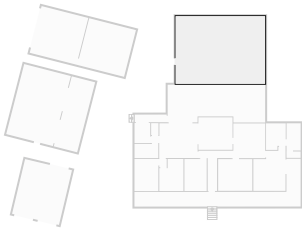

▼ Other
Ground Floor

WIDTH: 4.01 m • LENGTH: 0.95 m
AREA: 3.79 m² • PERIMETER: 9.90 m

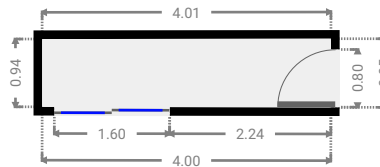
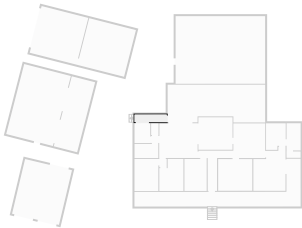

▼ Toilet
Ground Floor

WIDTH: 1.75 m • LENGTH: 0.80 m
AREA: 1.39 m² • PERIMETER: 5.09 m

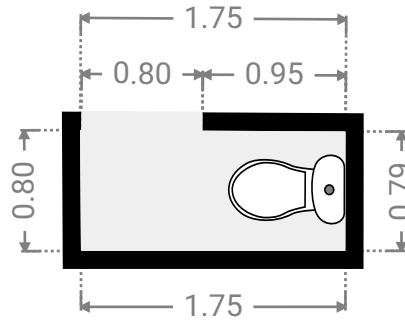
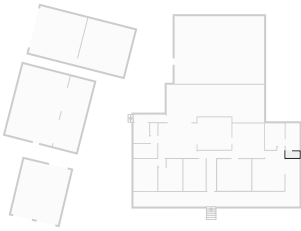

▼ Bathroom
Ground Floor

WIDTH: 1.75 m • LENGTH: 3.39 m
AREA: 5.93 m² • PERIMETER: 10.28 m

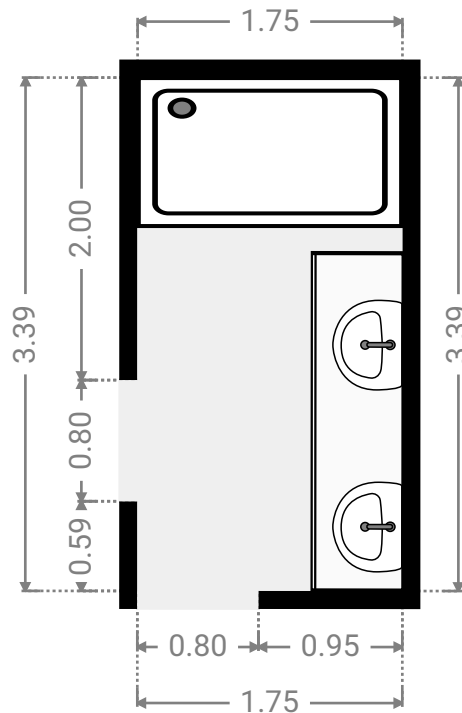
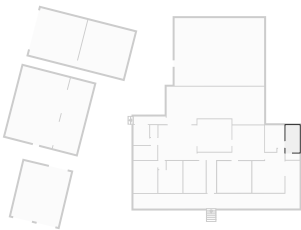

▼ Closet
Ground Floor

WIDTH: 2.45 m • LENGTH: 3.30 m
AREA: 7.57 m² • PERIMETER: 11.50 m

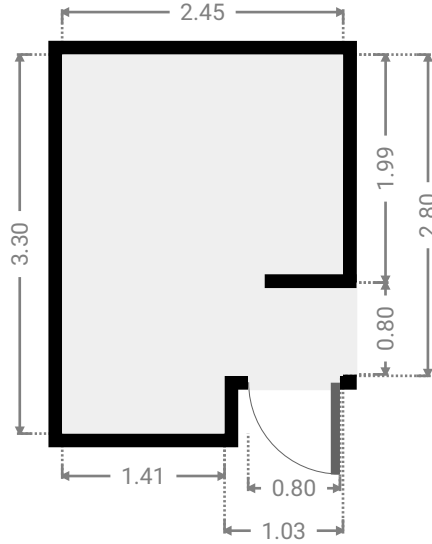
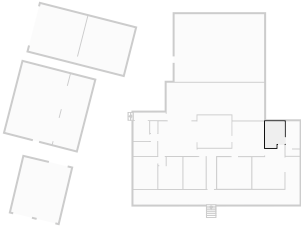

▼ Hall
Ground Floor

WIDTH: 4.01 m • LENGTH: 5.01 m
AREA: 8.47 m² • PERIMETER: 18.05 m

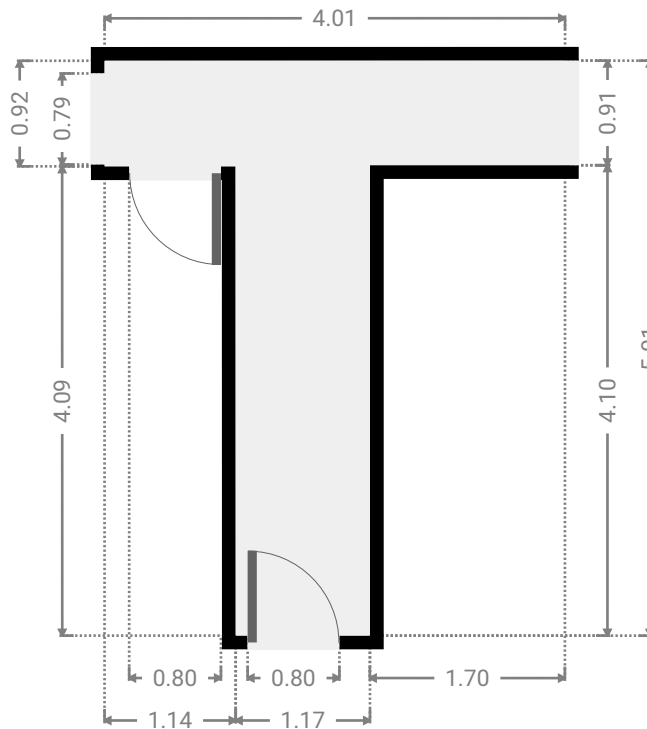
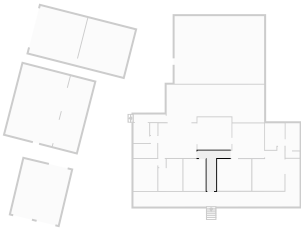

▼ **Bedroom**
Ground Floor

WIDTH: 4.25 m • LENGTH: 3.95 m
AREA: 16.76 m² • PERIMETER: 16.39 m

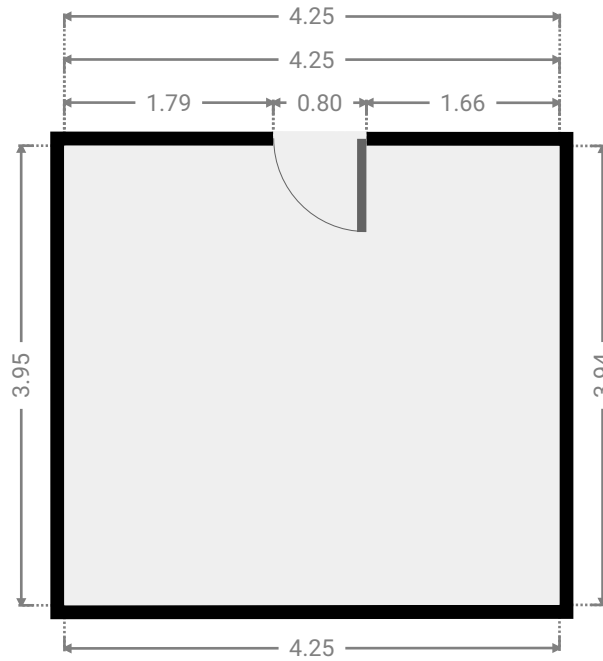
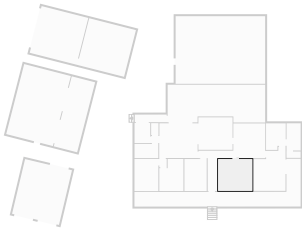

▼ **Dining Room**
Ground Floor

WIDTH: 4.17 m • LENGTH: 4.32 m
AREA: 17.34 m² • PERIMETER: 16.99 m

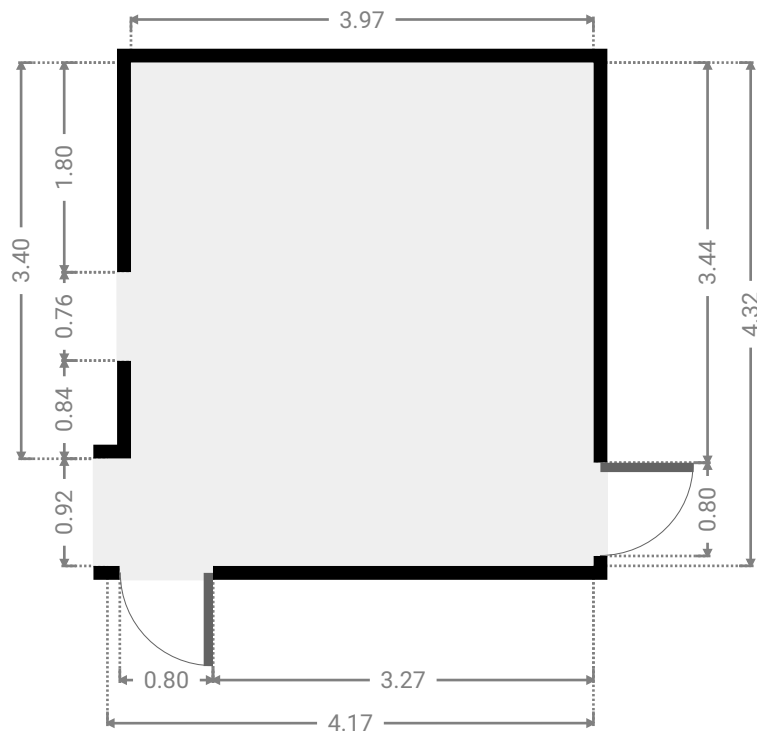

▼ **Toilet**
Ground Floor

WIDTH: 0.91 m • LENGTH: 1.48 m
AREA: 1.35 m² • PERIMETER: 4.78 m

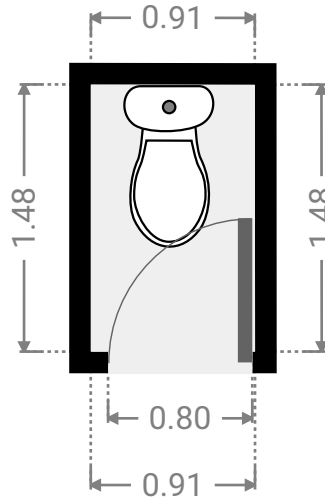
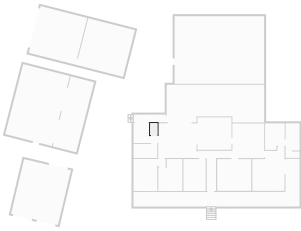

▼ **Laundry Room**
Ground Floor

WIDTH: 1.95 m • LENGTH: 2.50 m
AREA: 4.87 m² • PERIMETER: 8.90 m

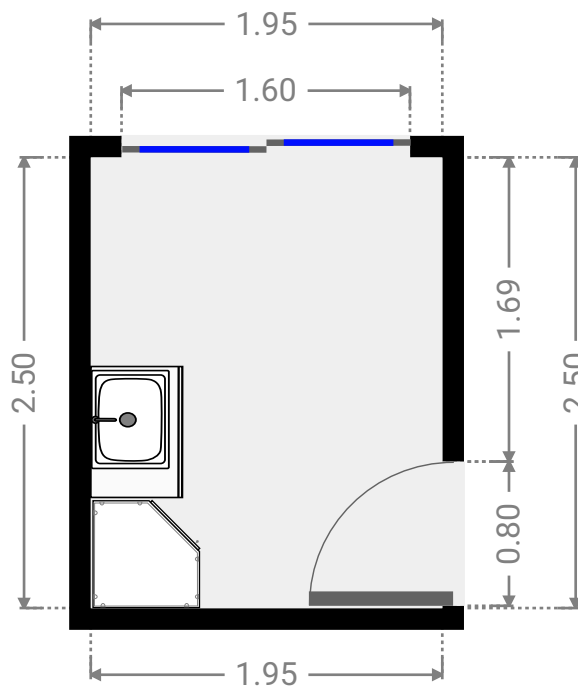
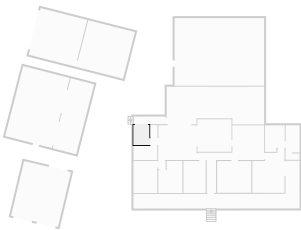

▼ Bathroom
Ground Floor

WIDTH: 2.96 m • LENGTH: 1.76 m
AREA: 5.21 m² • PERIMETER: 9.44 m

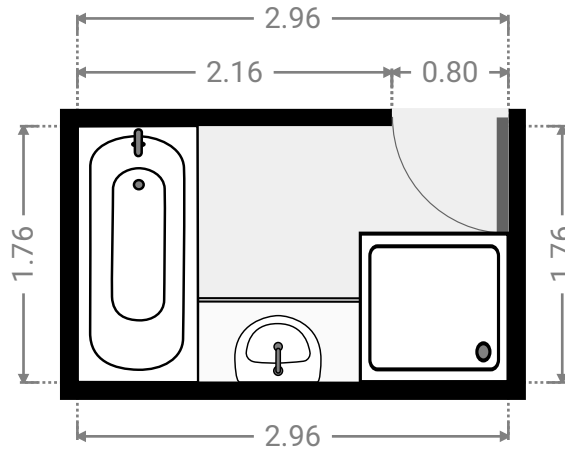
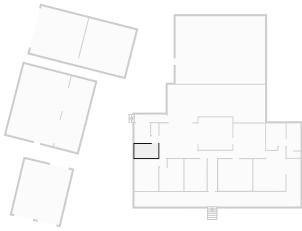

▼ Bedroom
Ground Floor

WIDTH: 2.97 m • LENGTH: 4.00 m
AREA: 11.88 m² • PERIMETER: 13.94 m

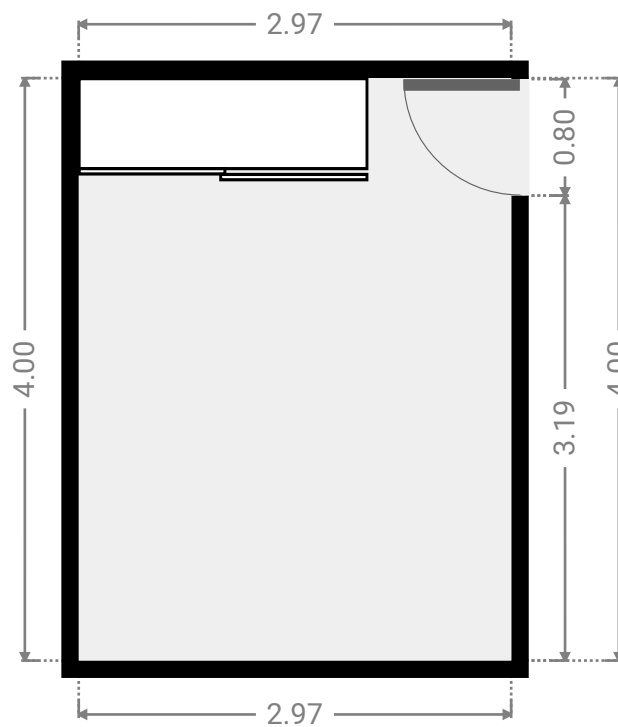
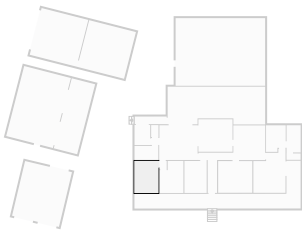

▼ **Bedroom**
Ground Floor

WIDTH: 3.00 m • LENGTH: 3.99 m
AREA: 10.78 m² • PERIMETER: 13.98 m

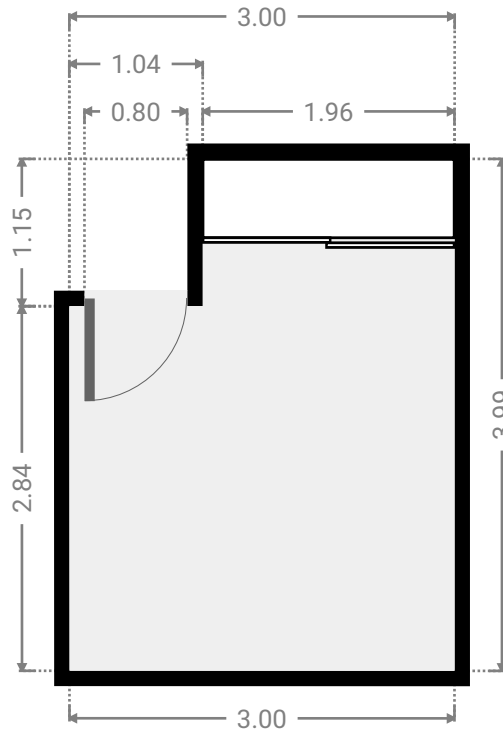
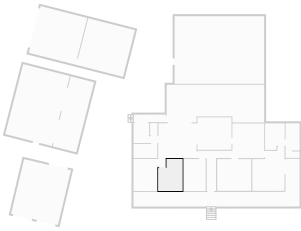

▼ **Hall**
Ground Floor

WIDTH: 0.92 m • LENGTH: 1.03 m
AREA: 0.95 m² • PERIMETER: 3.90 m

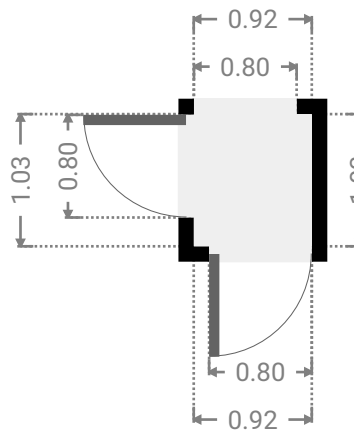
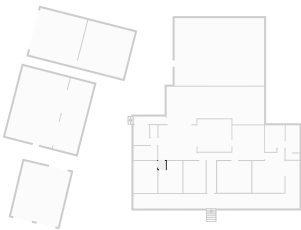

▼ Kitchen
Ground Floor

WIDTH: 4.25 m • LENGTH: 4.04 m
AREA: 17.17 m² • PERIMETER: 16.58 m

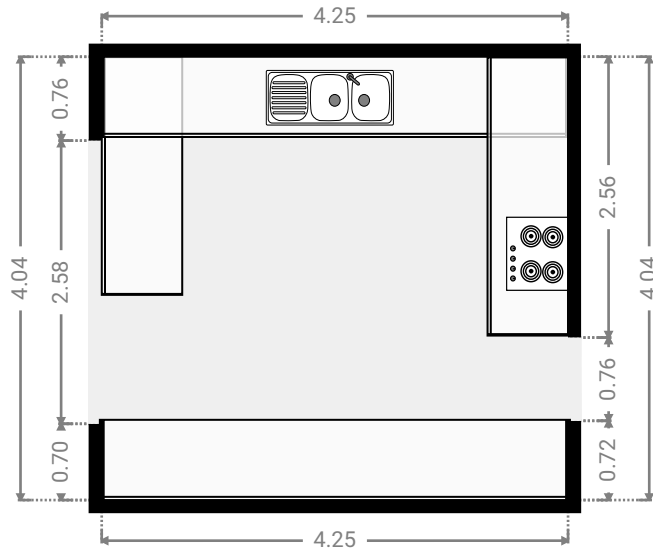
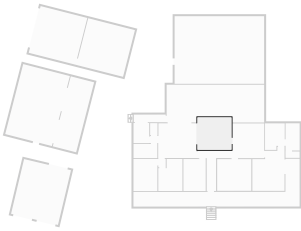

▼ Living Room
Ground Floor

WIDTH: 5.79 m • LENGTH: 4.32 m
AREA: 21.49 m² • PERIMETER: 20.21 m

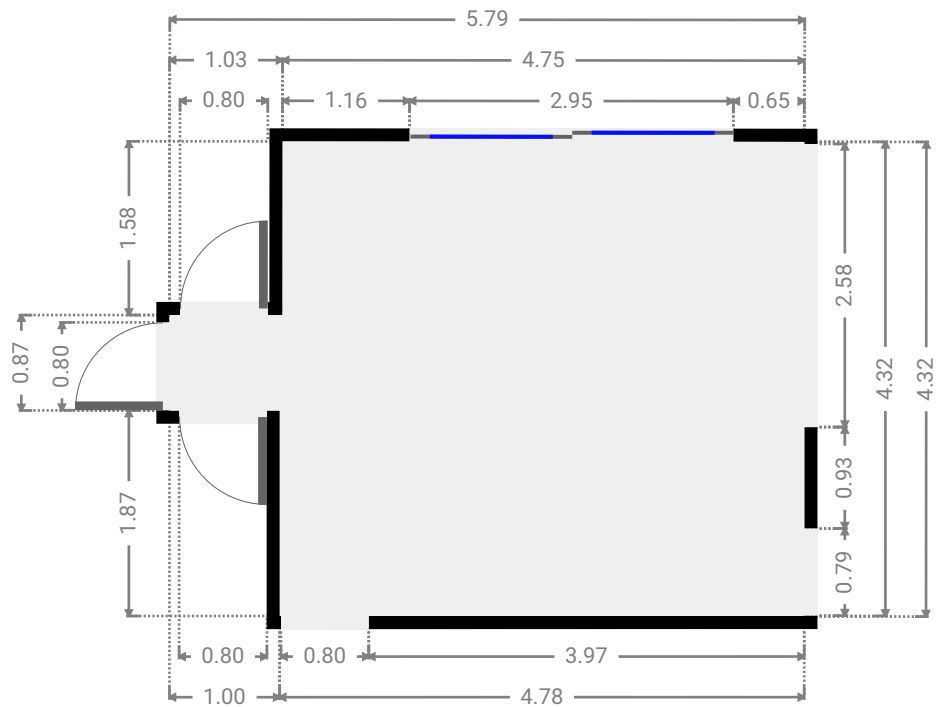
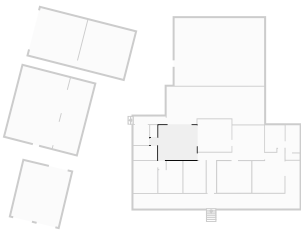

▼ **Bedroom**
Ground Floor

WIDTH: 2.77 m • LENGTH: 3.98 m
AREA: 11.03 m² • PERIMETER: 13.50 m

