

Ground Floor

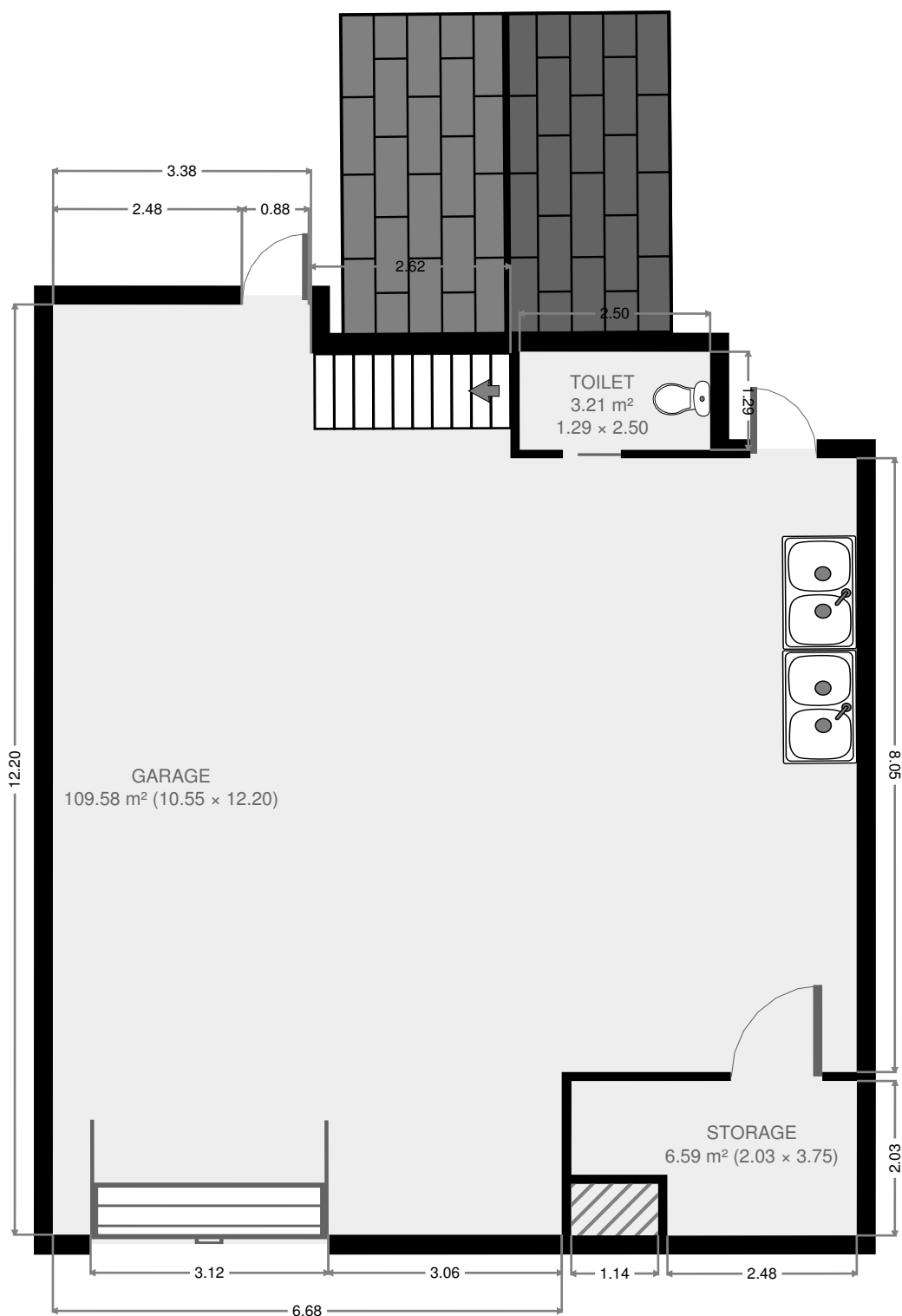

THIS FLOORPLAN IS PROVIDED WITHOUT WARRANTY OF ANY KIND. SENSOPIA DISCLAIMS ANY WARRANTY INCLUDING, WITHOUT LIMITATION, SATISFACTORY QUALITY OR ACCURACY OF DIMENSIONS.

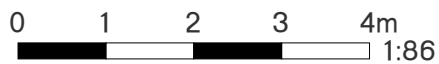

121 Wandal Road

Garage

Width: 10.55 m
 Length: 12.20 m
 Area: 109.58 m²
 Perimeter: 45.49 m
 Ceiling Height: 2.17 m

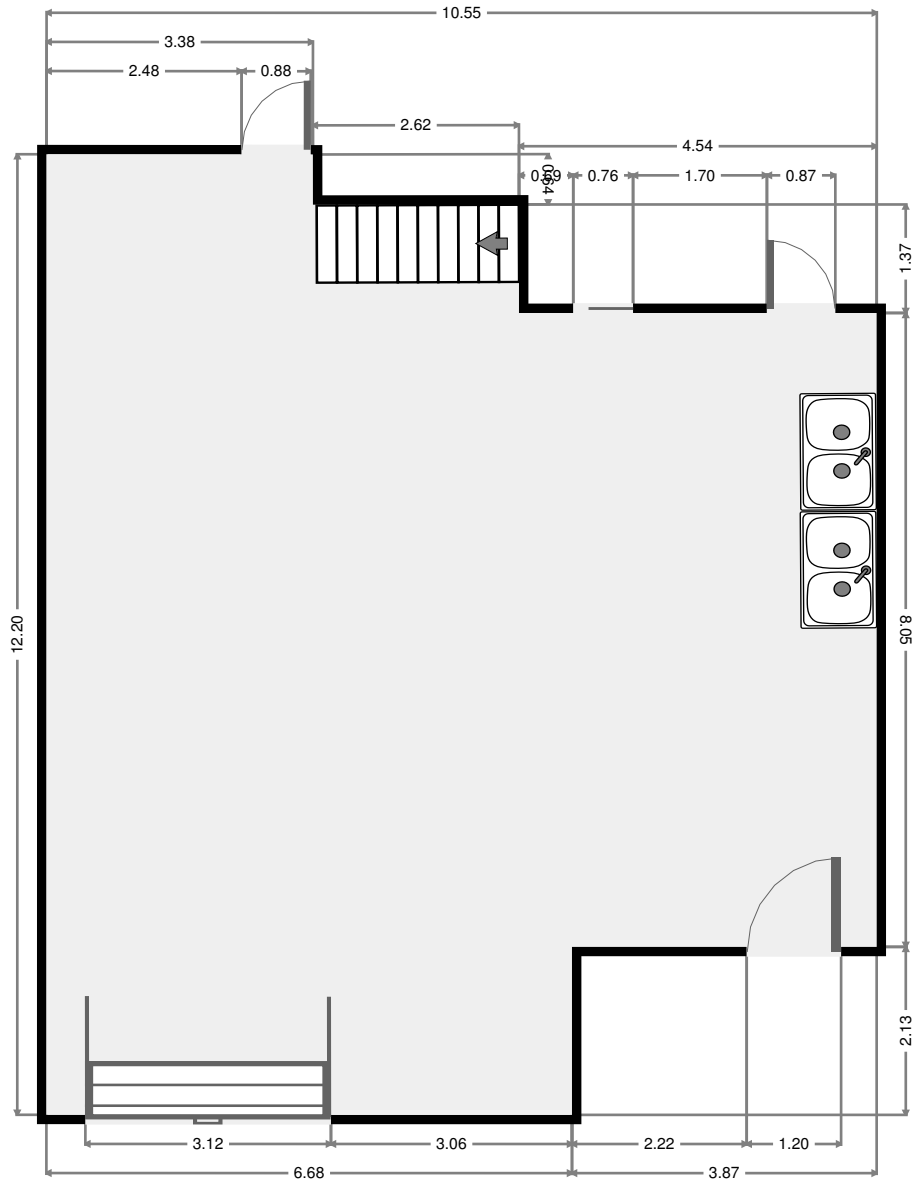
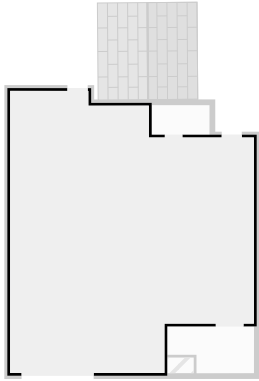

THIS FLOORPLAN IS PROVIDED WITHOUT WARRANTY OF ANY KIND. SENSOPIA DISCLAIMS ANY WARRANTY INCLUDING, WITHOUT LIMITATION, SATISFACTORY QUALITY OR ACCURACY OF DIMENSIONS.

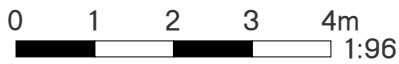

121 Wandal Road

2016-12-14

Toilet

Width: 1.29 m
 Length: 2.50 m
 Area: 3.21 m²
 Perimeter: 7.57 m

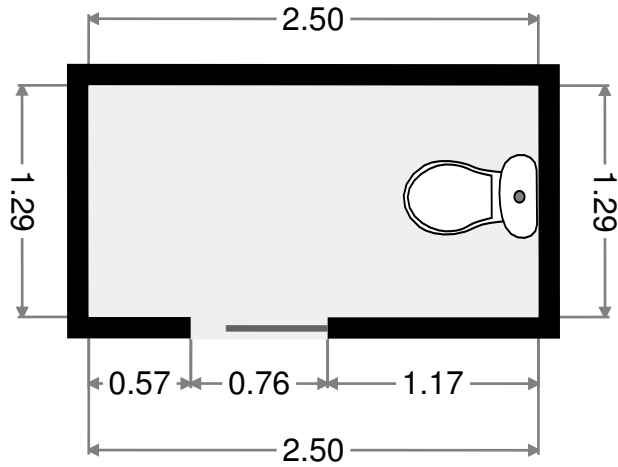
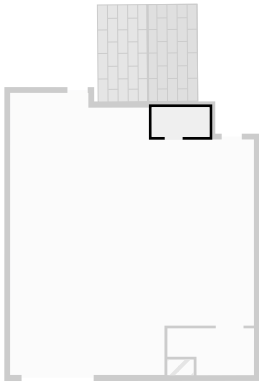

Storage

Width: 2.03 m
 Length: 3.75 m
 Area: 6.59 m²
 Perimeter: 11.54 m
 Ceiling Height: 2.17 m

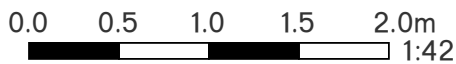
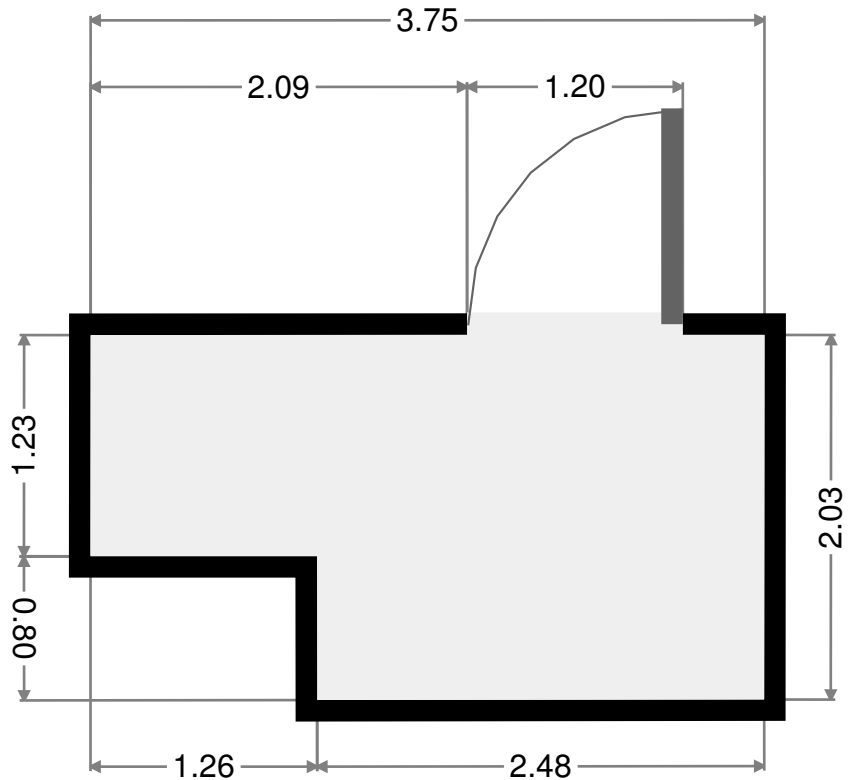
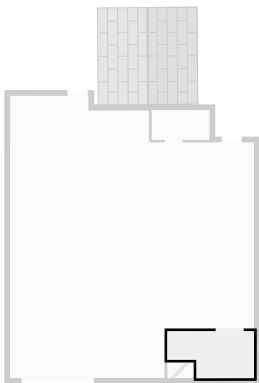

THIS FLOORPLAN IS PROVIDED WITHOUT WARRANTY OF ANY KIND. SENSOPIA DISCLAIMS ANY WARRANTY INCLUDING, WITHOUT LIMITATION, SATISFACTORY QUALITY OR ACCURACY OF DIMENSIONS.

1st Floor

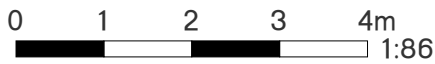
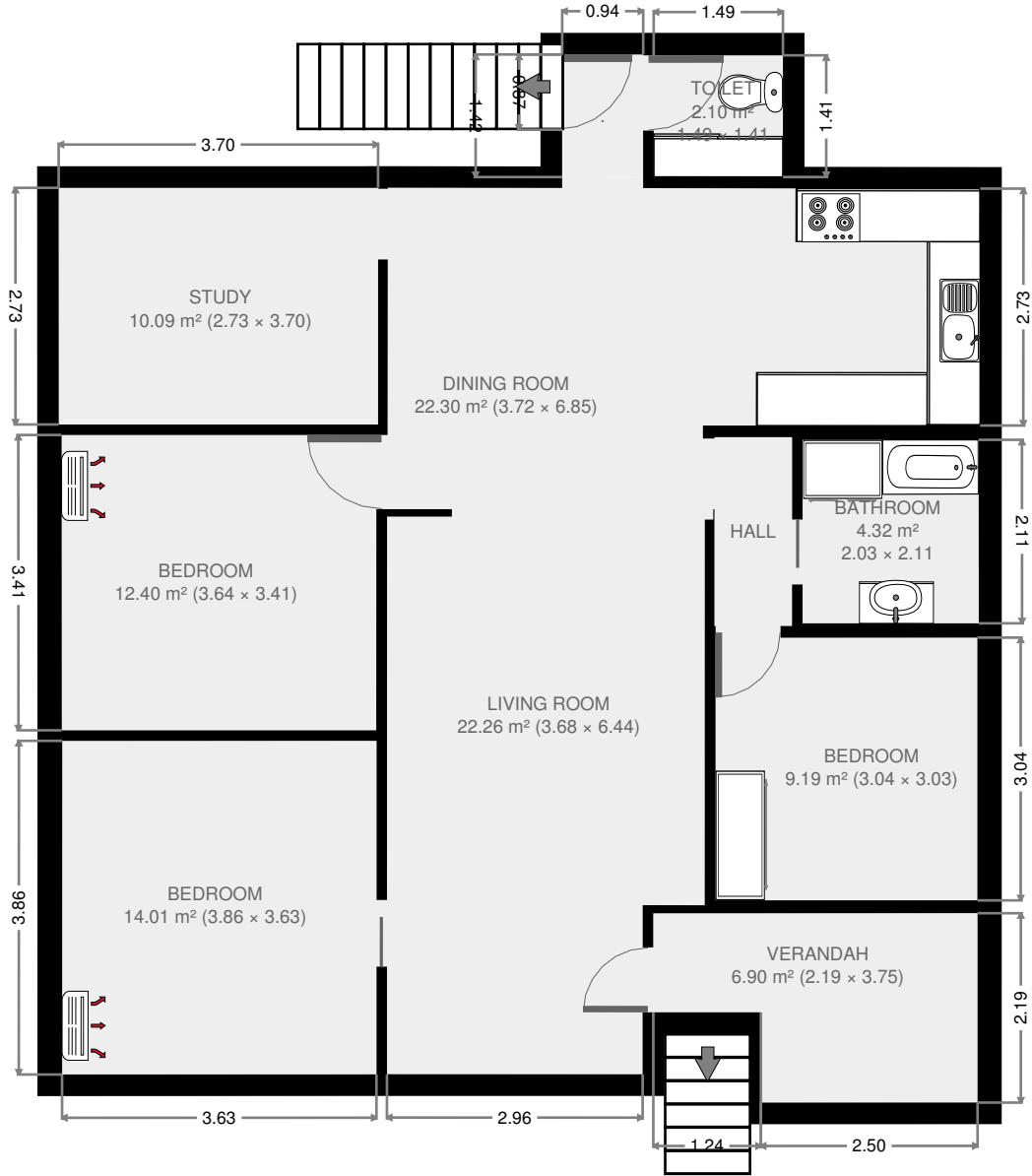

121 Wandal Road

THIS FLOORPLAN IS PROVIDED WITHOUT WARRANTY OF ANY KIND. SENSOPIA DISCLAIMS ANY WARRANTY INCLUDING, WITHOUT LIMITATION, SATISFACTORY QUALITY OR ACCURACY OF DIMENSIONS.

Living Room

Width: 3.68 m
 Length: 6.44 m
 Area: 22.26 m²
 Perimeter: 20.23 m
 Ceiling Height: 2.17 m

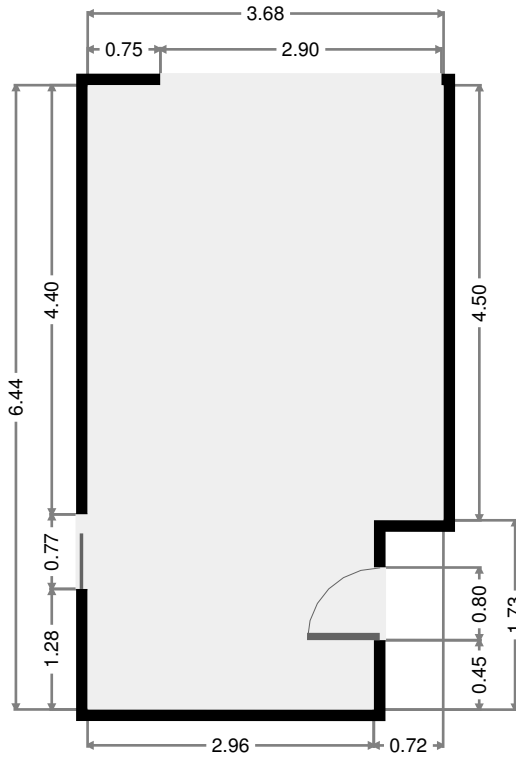
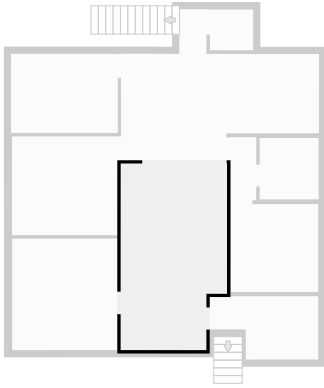

Dining Room

Width: 3.72 m
 Length: 6.85 m
 Area: 22.30 m²
 Perimeter: 21.11 m
 Ceiling Height: 2.17 m

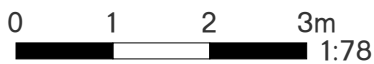
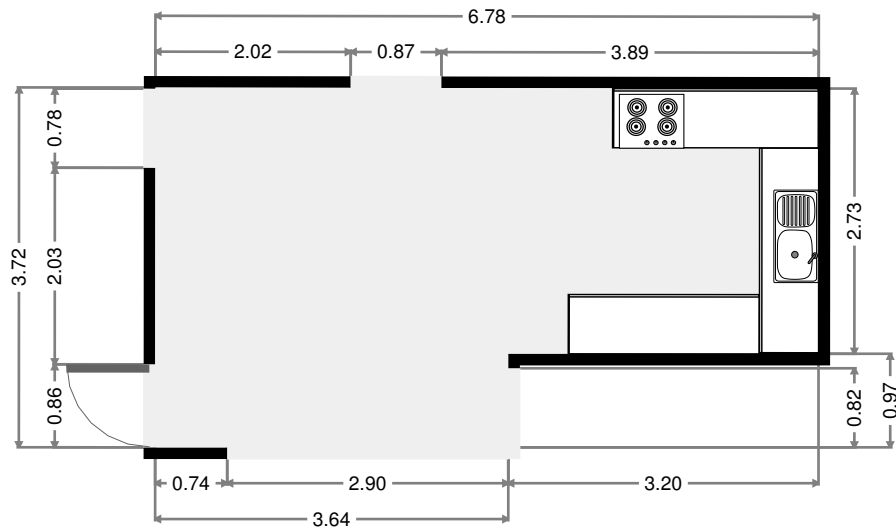
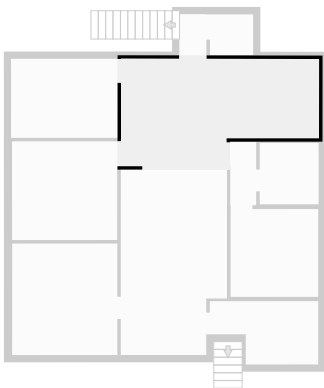

THIS FLOORPLAN IS PROVIDED WITHOUT WARRANTY OF ANY KIND. SENSOPIA DISCLAIMS ANY WARRANTY INCLUDING, WITHOUT LIMITATION, SATISFACTORY QUALITY OR ACCURACY OF DIMENSIONS.

Bedroom

Width: 3.41 m
 Length: 3.64 m
 Area: 12.40 m²
 Perimeter: 14.10 m

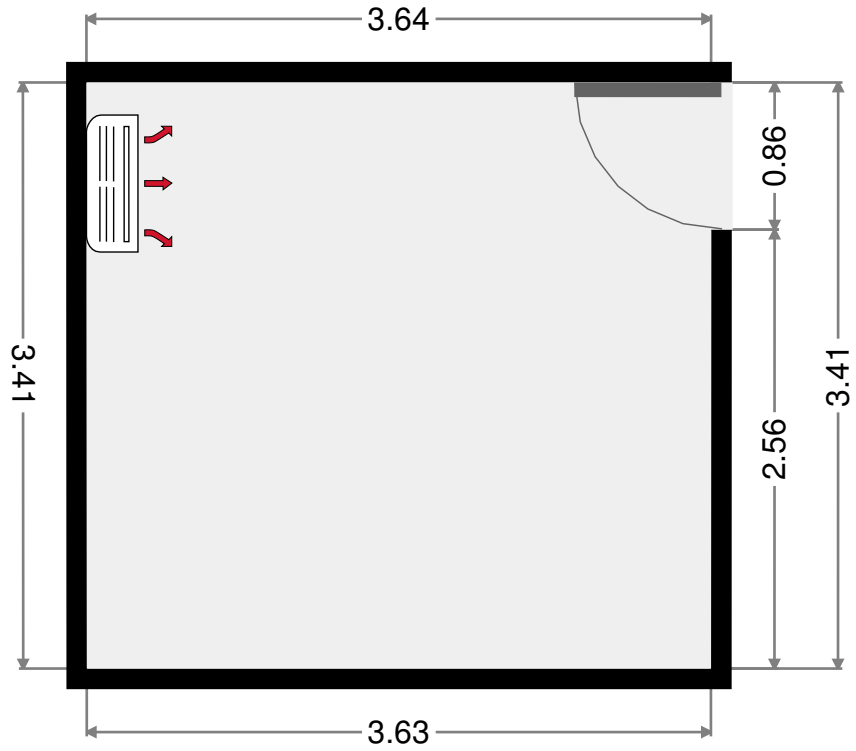
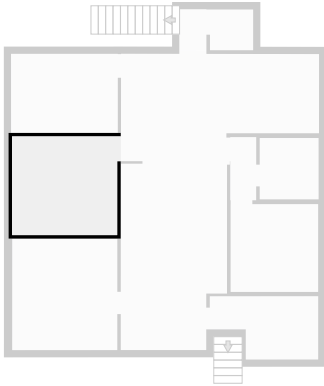

Study

Width: 2.73 m
 Length: 3.70 m
 Area: 10.09 m²
 Perimeter: 12.85 m

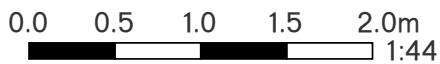
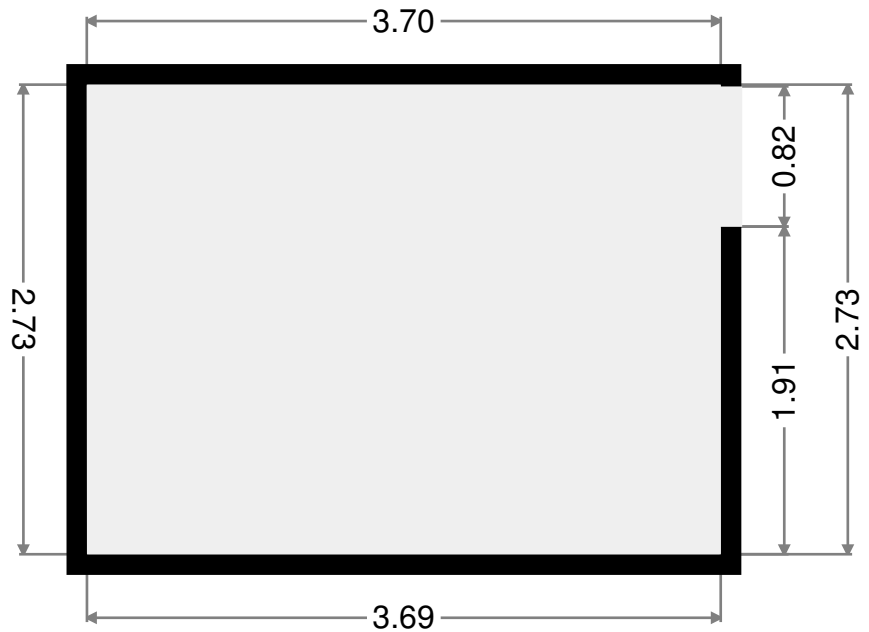
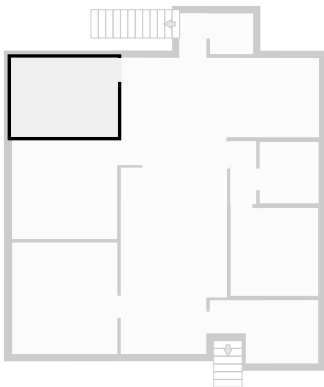

THIS FLOORPLAN IS PROVIDED WITHOUT WARRANTY OF ANY KIND. SENSOPIA DISCLAIMS ANY WARRANTY INCLUDING, WITHOUT LIMITATION, SATISFACTORY QUALITY OR ACCURACY OF DIMENSIONS.

Bedroom

Width: 3.63 m
 Length: 3.86 m
 Area: 14.01 m²
 Perimeter: 14.98 m

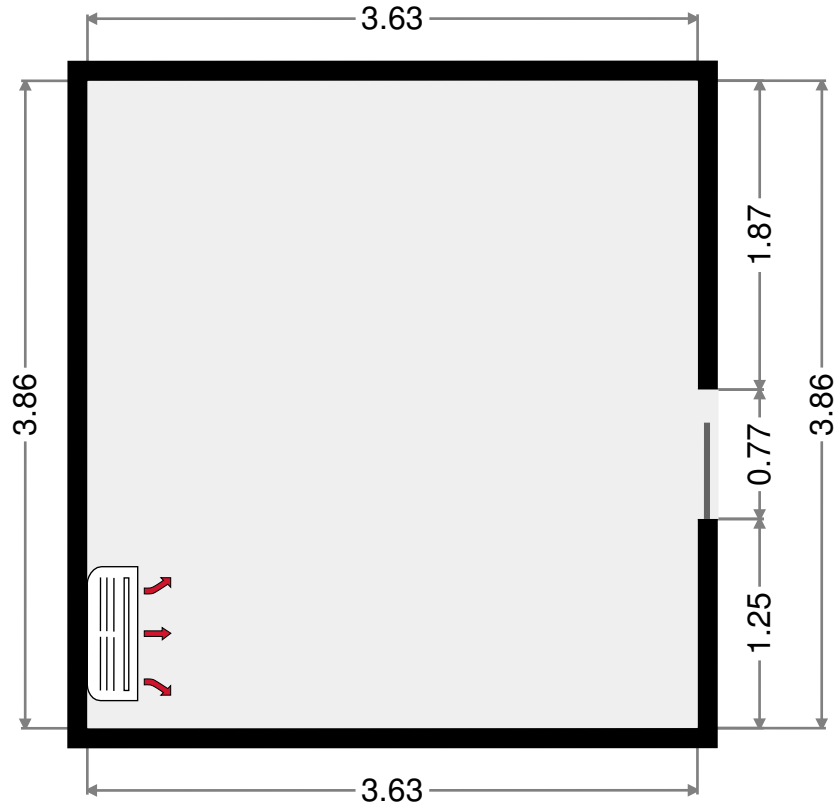
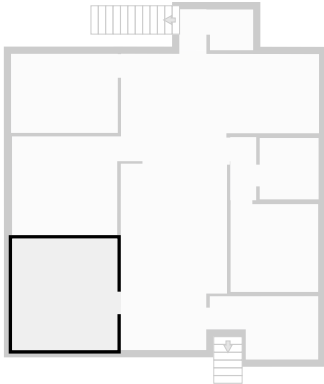

Hall

Width: 0.90 m
 Length: 2.18 m
 Area: 1.96 m²
 Perimeter: 6.16 m

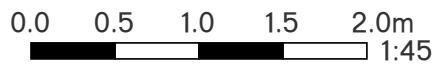
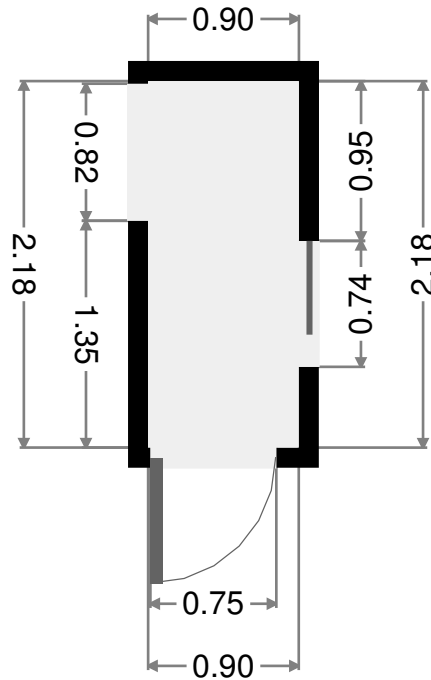
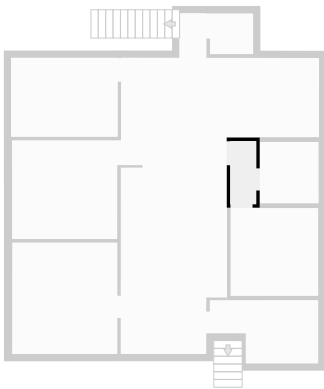

THIS FLOORPLAN IS PROVIDED WITHOUT WARRANTY OF ANY KIND. SENSOPIA DISCLAIMS ANY WARRANTY INCLUDING, WITHOUT LIMITATION, SATISFACTORY QUALITY OR ACCURACY OF DIMENSIONS.

Bathroom

Width: 2.03 m
 Length: 2.11 m
 Area: 4.32 m²
 Perimeter: 8.31 m

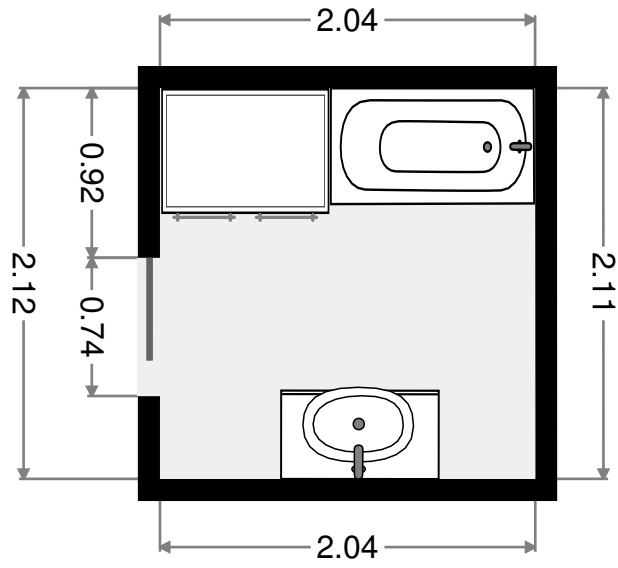
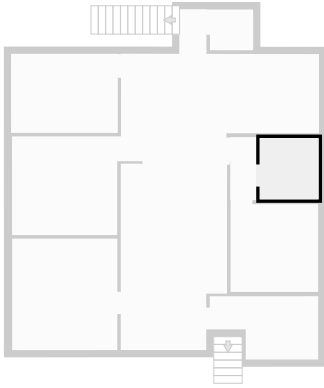

Bedroom

Width: 3.03 m
 Length: 3.04 m
 Area: 9.19 m²
 Perimeter: 12.12 m

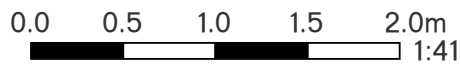
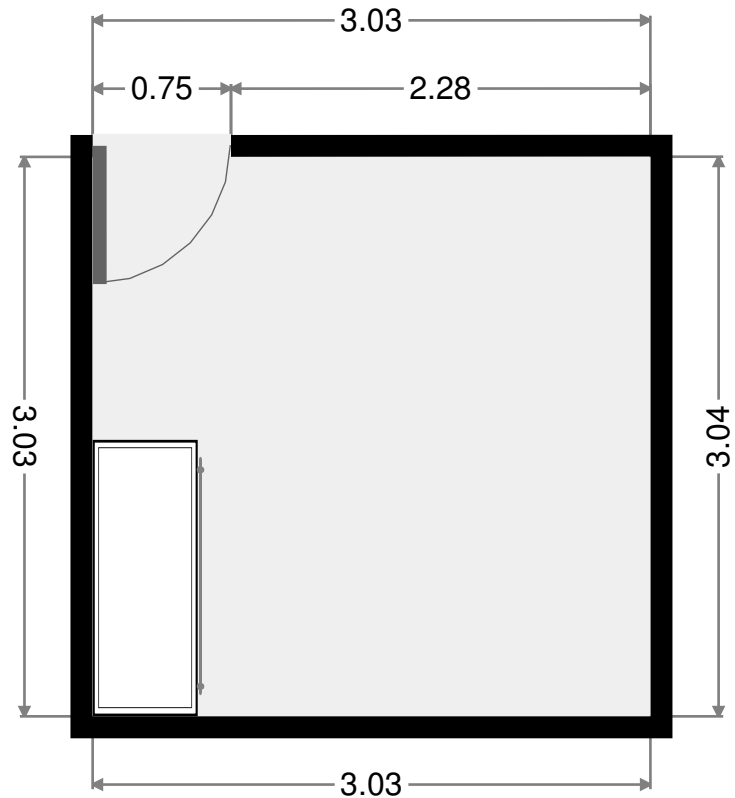
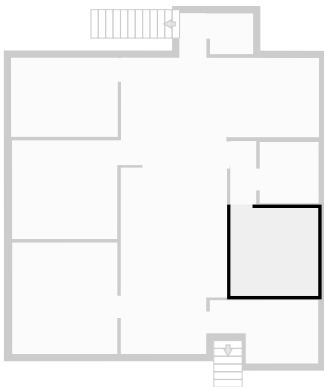

THIS FLOORPLAN IS PROVIDED WITHOUT WARRANTY OF ANY KIND. SENSOPIA DISCLAIMS ANY WARRANTY INCLUDING, WITHOUT LIMITATION, SATISFACTORY QUALITY OR ACCURACY OF DIMENSIONS.

- Width: 0.94 m
 Length: 1.42 m
 Area: 1.33 m²
 Perimeter: 4.70 m

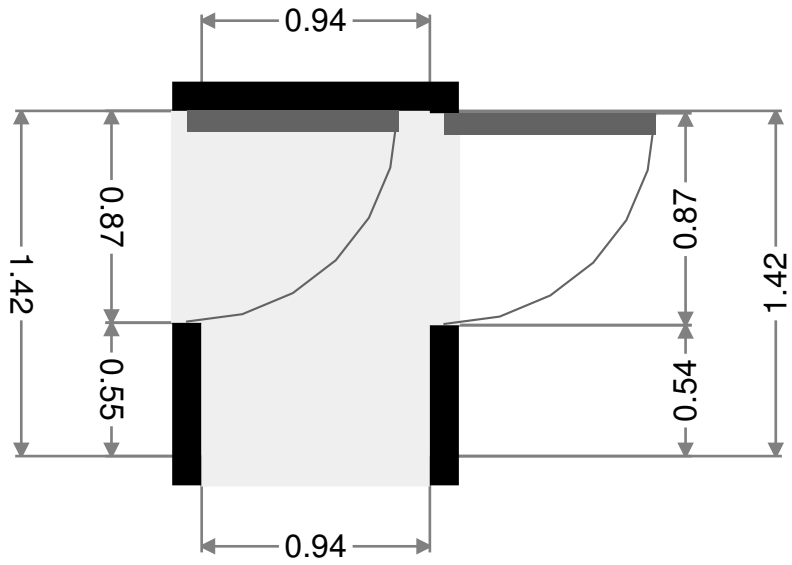
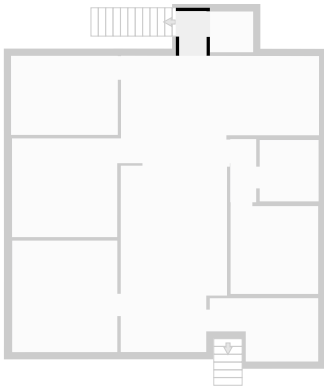

Toilet

- Width: 1.41 m
 Length: 1.49 m
 Area: 2.10 m²
 Perimeter: 5.80 m

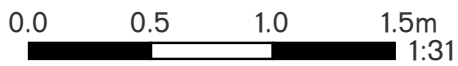
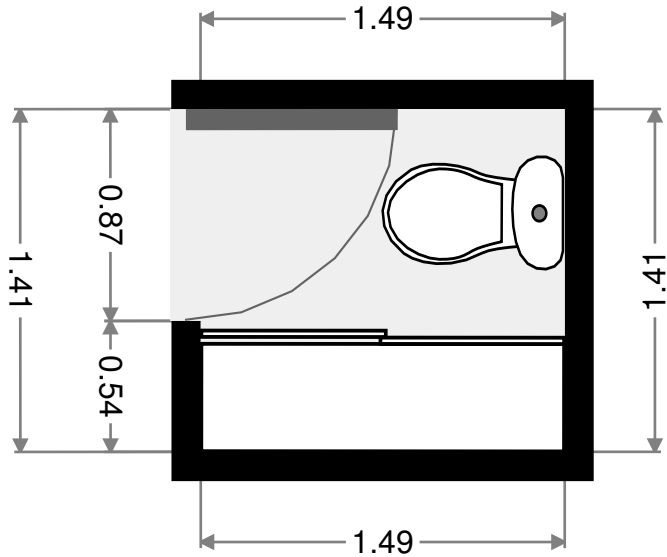
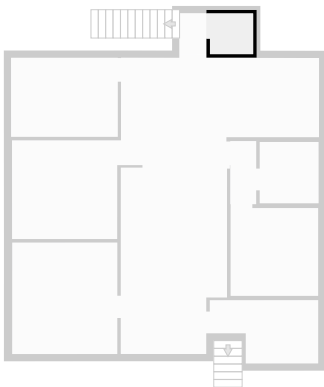

THIS FLOORPLAN IS PROVIDED WITHOUT WARRANTY OF ANY KIND. SENSOPIA DISCLAIMS ANY WARRANTY INCLUDING, WITHOUT LIMITATION, SATISFACTORY QUALITY OR ACCURACY OF DIMENSIONS.

Verandah

Width: 2.19 m
Length: 3.75 m
Area: 6.90 m²
Perimeter: 11.87 m
Ceiling Height: 2.17 m

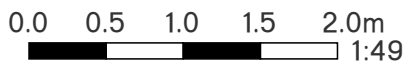
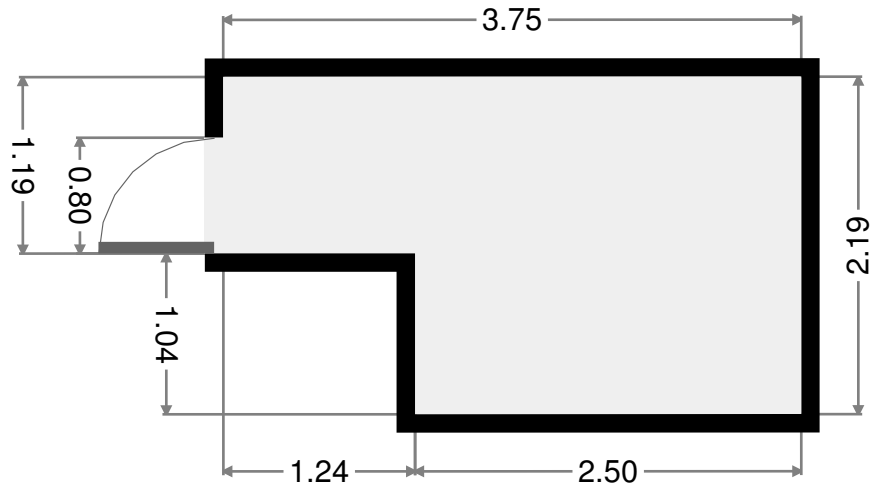
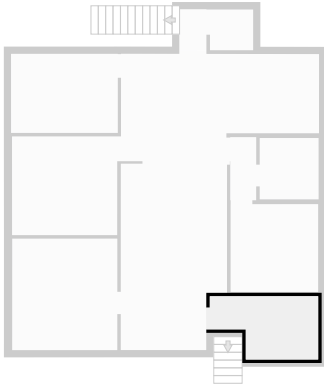

THIS FLOORPLAN IS PROVIDED WITHOUT WARRANTY OF ANY KIND. SENSOPIA DISCLAIMS ANY WARRANTY INCLUDING, WITHOUT LIMITATION, SATISFACTORY QUALITY OR ACCURACY OF DIMENSIONS.

121 Wandal Road

2016-12-14