

# 120 Park Street

**SUBMITTED BY**

Ray White Rockhampton Casey  
stockers@cqoz.com

---

**CREATED ON**

2022-12-20

---

**Floors**

2

---

▼ Ground Floor

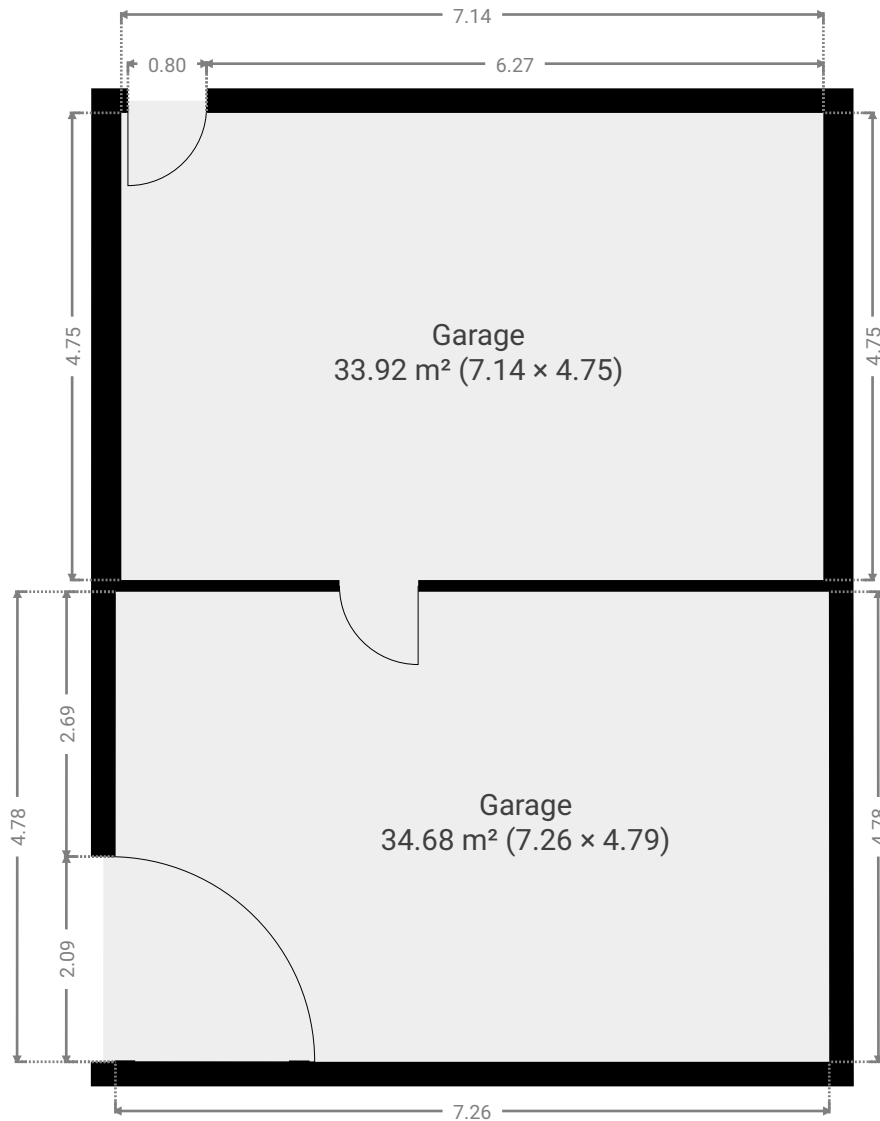

▼ Garage  
Ground Floor

WIDTH: 4.79 m • LENGTH: 7.26 m  
AREA: 34.68 m<sup>2</sup> • PERIMETER: 24.07 m

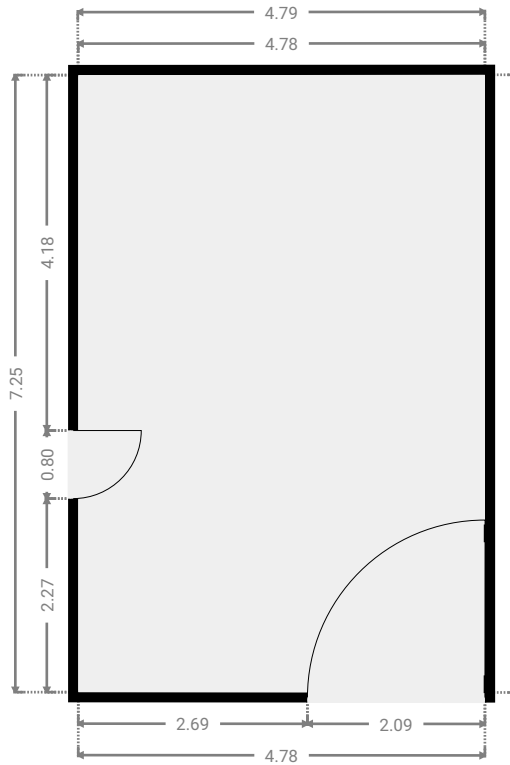
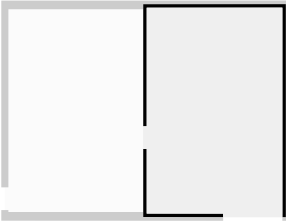

▼ Garage  
Ground Floor

WIDTH: 4.75 m • LENGTH: 7.14 m  
AREA: 33.92 m<sup>2</sup> • PERIMETER: 23.78 m

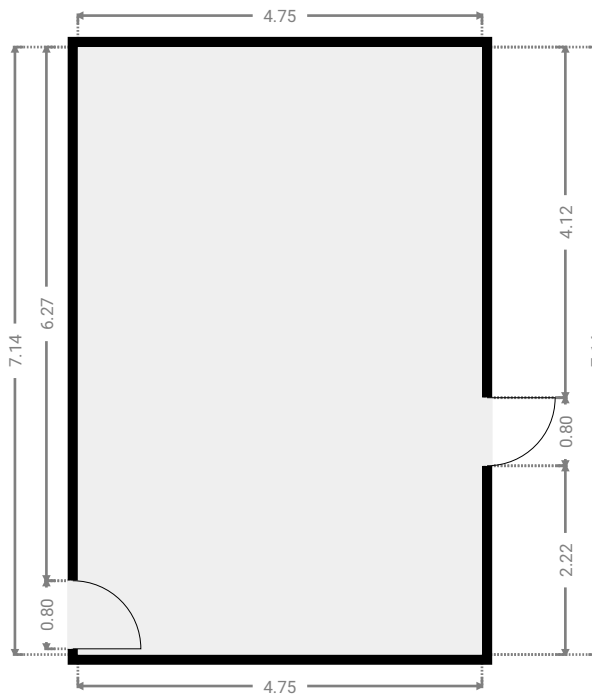
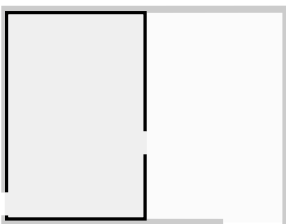

▼ 1st Floor

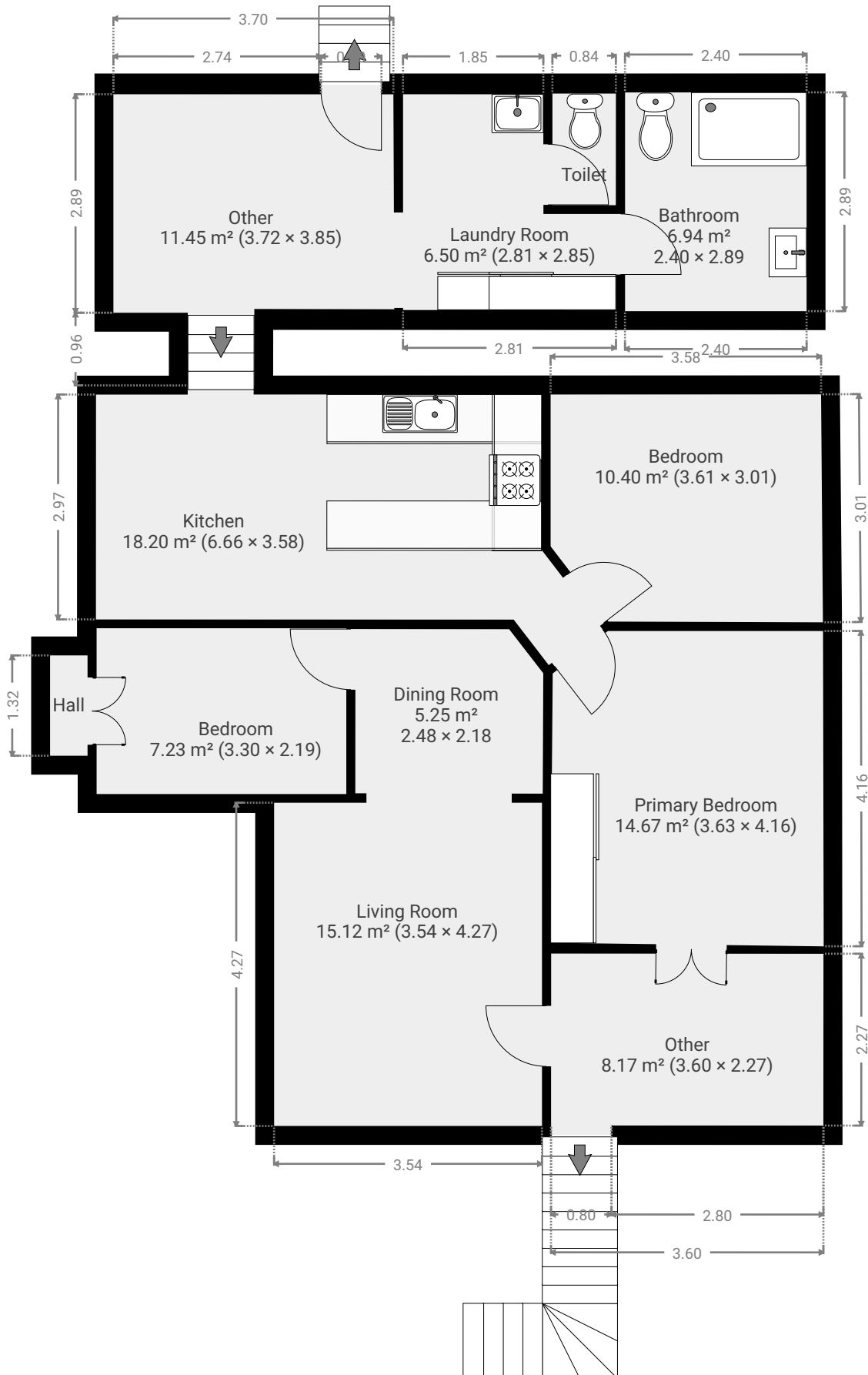

▼ **Bathroom**  
1st Floor

WIDTH: 2.40 m • LENGTH: 2.89 m  
AREA: 6.94 m<sup>2</sup> • PERIMETER: 10.58 m

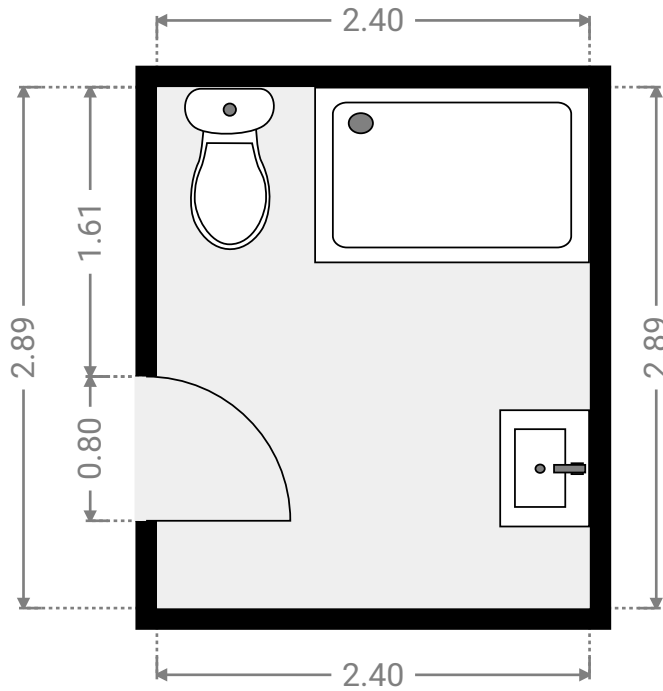
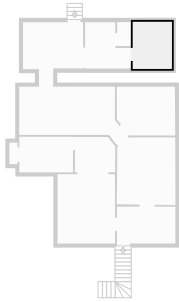

▼ **Bedroom**  
1st Floor

WIDTH: 3.30 m • LENGTH: 2.19 m  
AREA: 7.23 m<sup>2</sup> • PERIMETER: 10.98 m

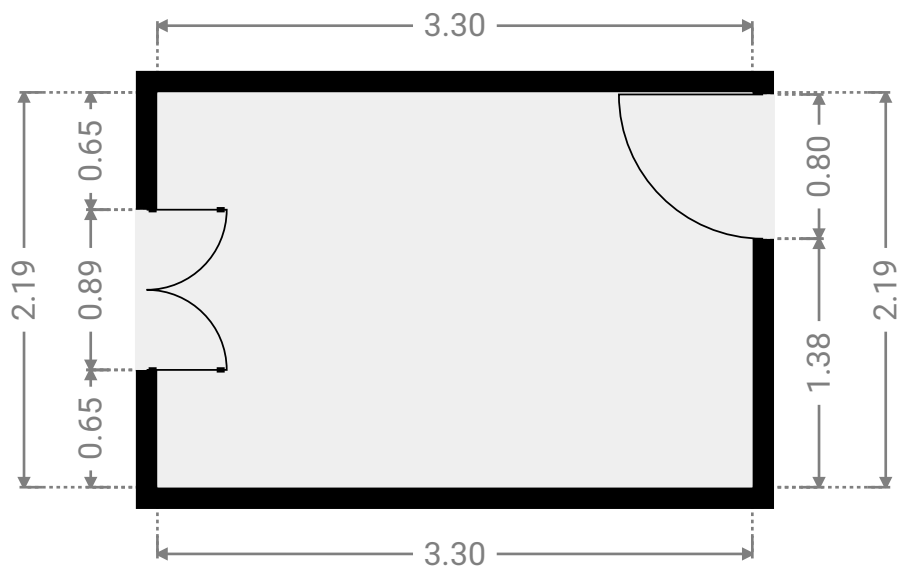
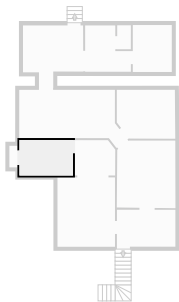

▼ **Bedroom**  
1st Floor

WIDTH: 3.61 m • LENGTH: 3.01 m  
AREA: 10.40 m<sup>2</sup> • PERIMETER: 12.68 m

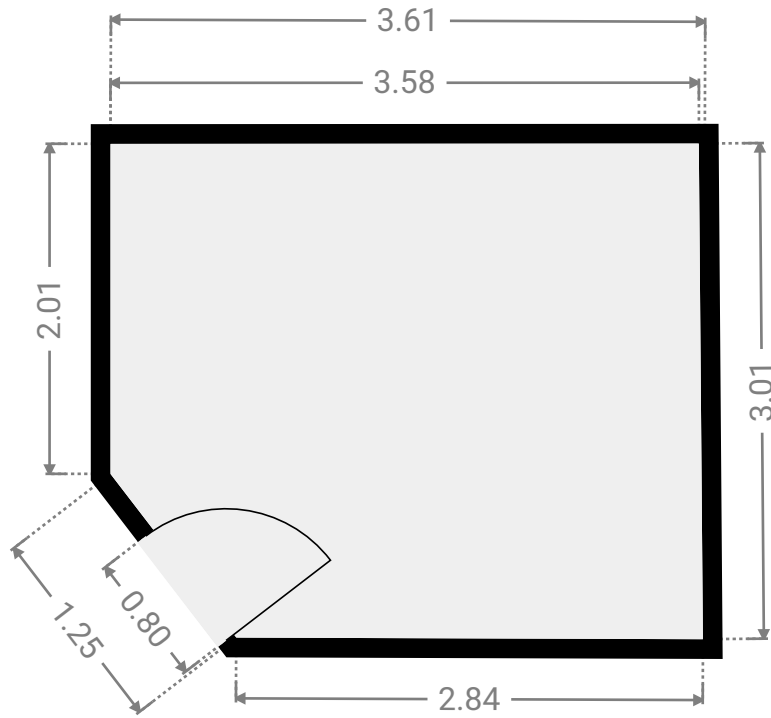
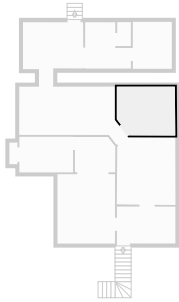

▼ **Dining Room**  
1st Floor

WIDTH: 2.48 m • LENGTH: 2.18 m  
AREA: 5.25 m<sup>2</sup> • PERIMETER: 9.00 m

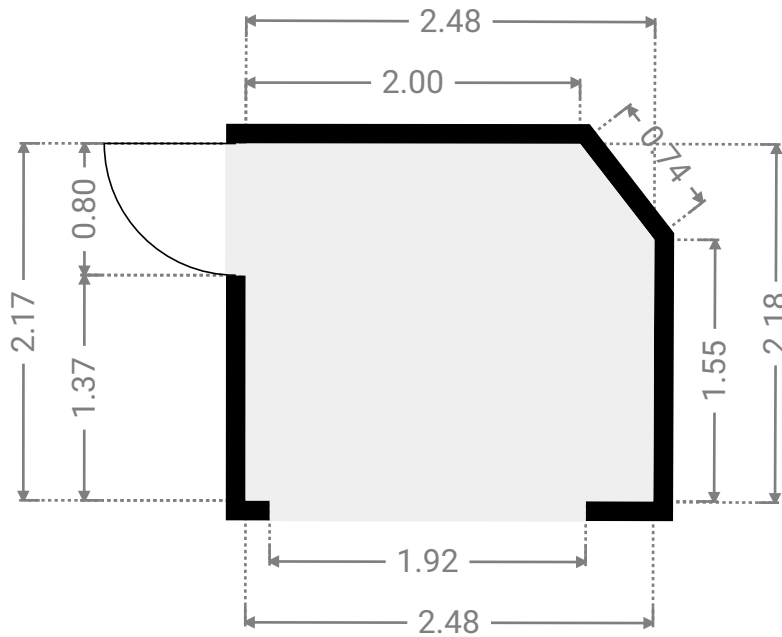
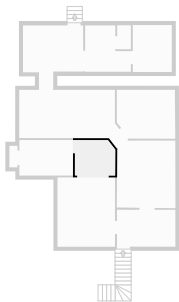

▼ **Hall**  
1st Floor

WIDTH: 0.49 m • LENGTH: 1.32 m  
AREA: 0.66 m<sup>2</sup> • PERIMETER: 3.64 m

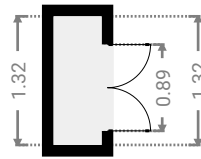
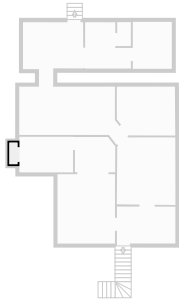

▼ **Kitchen**  
1st Floor

WIDTH: 6.66 m • LENGTH: 3.58 m  
AREA: 18.20 m<sup>2</sup> • PERIMETER: 19.31 m

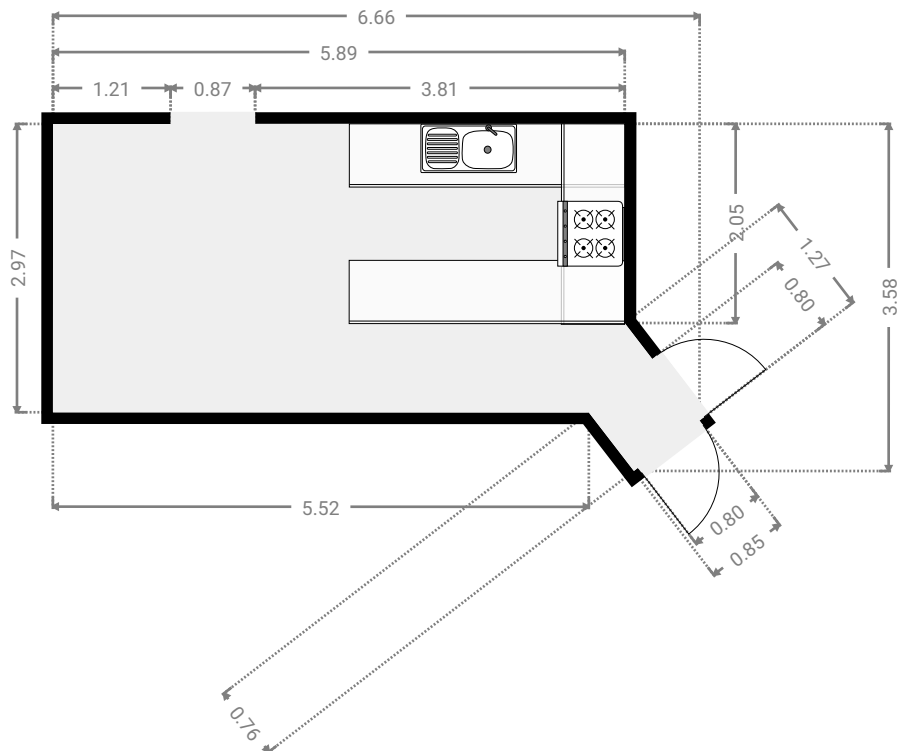
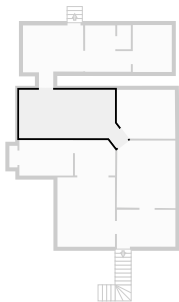

▼ Laundry Room  
1st Floor

WIDTH: 2.81 m • LENGTH: 2.85 m  
AREA: 6.50 m<sup>2</sup> • PERIMETER: 11.33 m

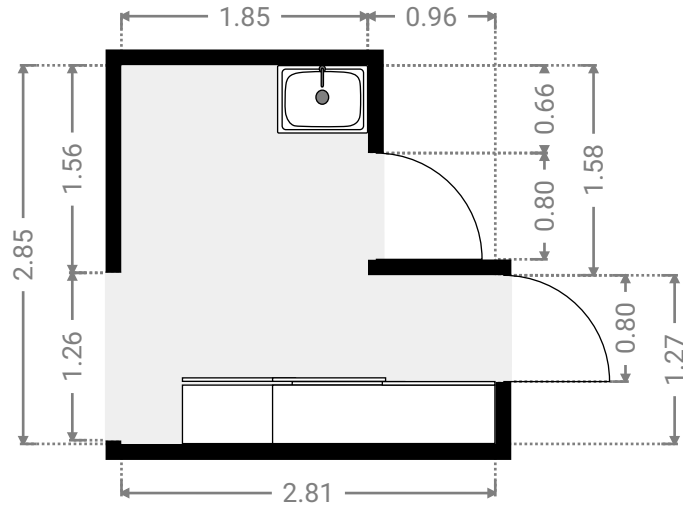
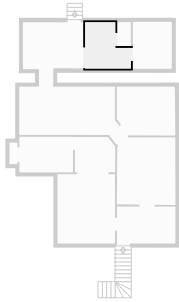

▼ Living Room  
1st Floor

WIDTH: 3.54 m • LENGTH: 4.27 m  
AREA: 15.12 m<sup>2</sup> • PERIMETER: 15.62 m

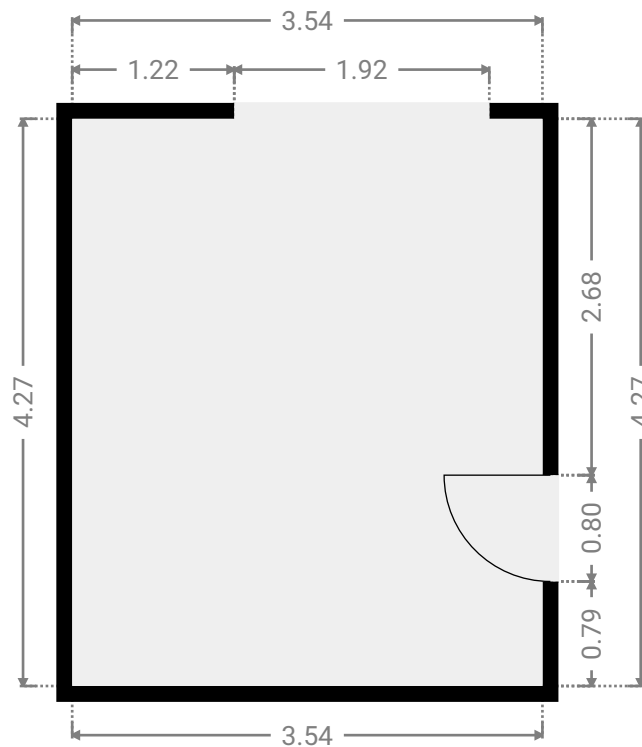
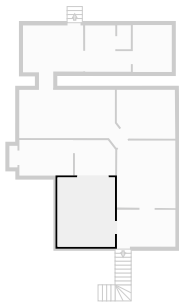



▼ Other  
1st Floor

WIDTH: 3.60 m • LENGTH: 2.27 m  
AREA: 8.17 m<sup>2</sup> • PERIMETER: 11.74 m

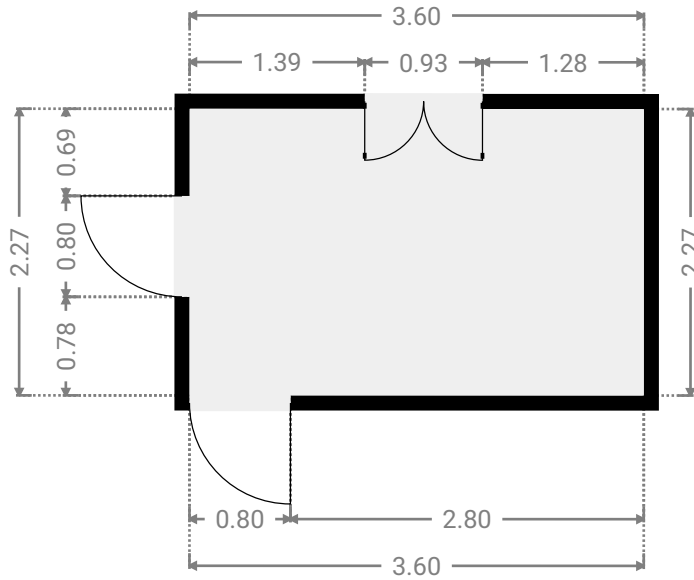
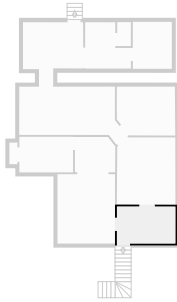

▼ Other  
1st Floor

WIDTH: 3.72 m • LENGTH: 3.85 m  
AREA: 11.45 m<sup>2</sup> • PERIMETER: 15.11 m

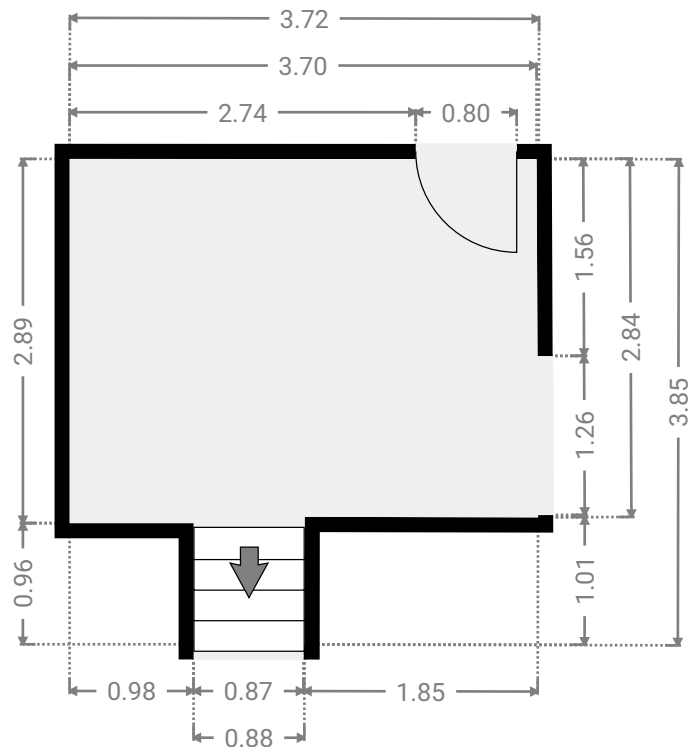
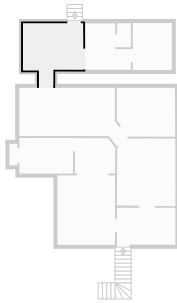

▼ **Primary Bedroom**  
1st Floor

WIDTH: 3.63 m • LENGTH: 4.16 m  
AREA: 14.67 m<sup>2</sup> • PERIMETER: 15.10 m

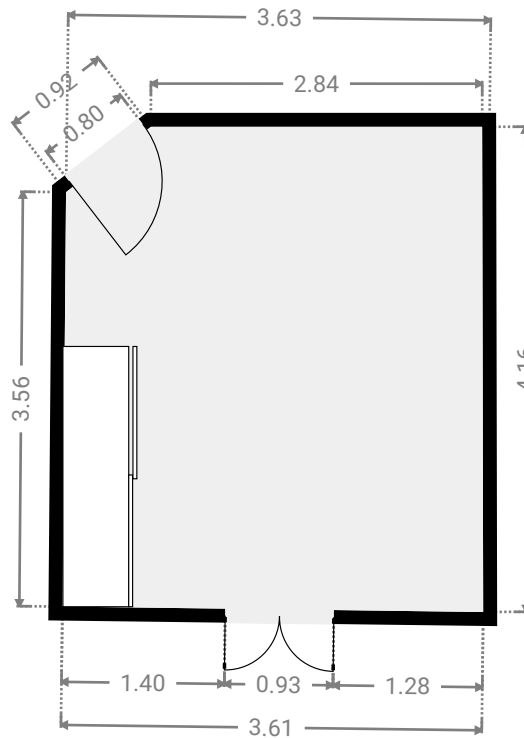
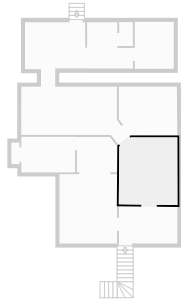

▼ **Toilet**  
1st Floor

WIDTH: 0.84 m • LENGTH: 1.47 m  
AREA: 1.24 m<sup>2</sup> • PERIMETER: 4.62 m

