

# 12 Kawana Close

**SUBMITTED BY**

Ray White Rockhampton Casey  
stockers@cqoz.com

---

**CREATED ON**

2022-09-28

---

**Floors**

1

---

FLOORS: 1

## ▼ Ground Floor

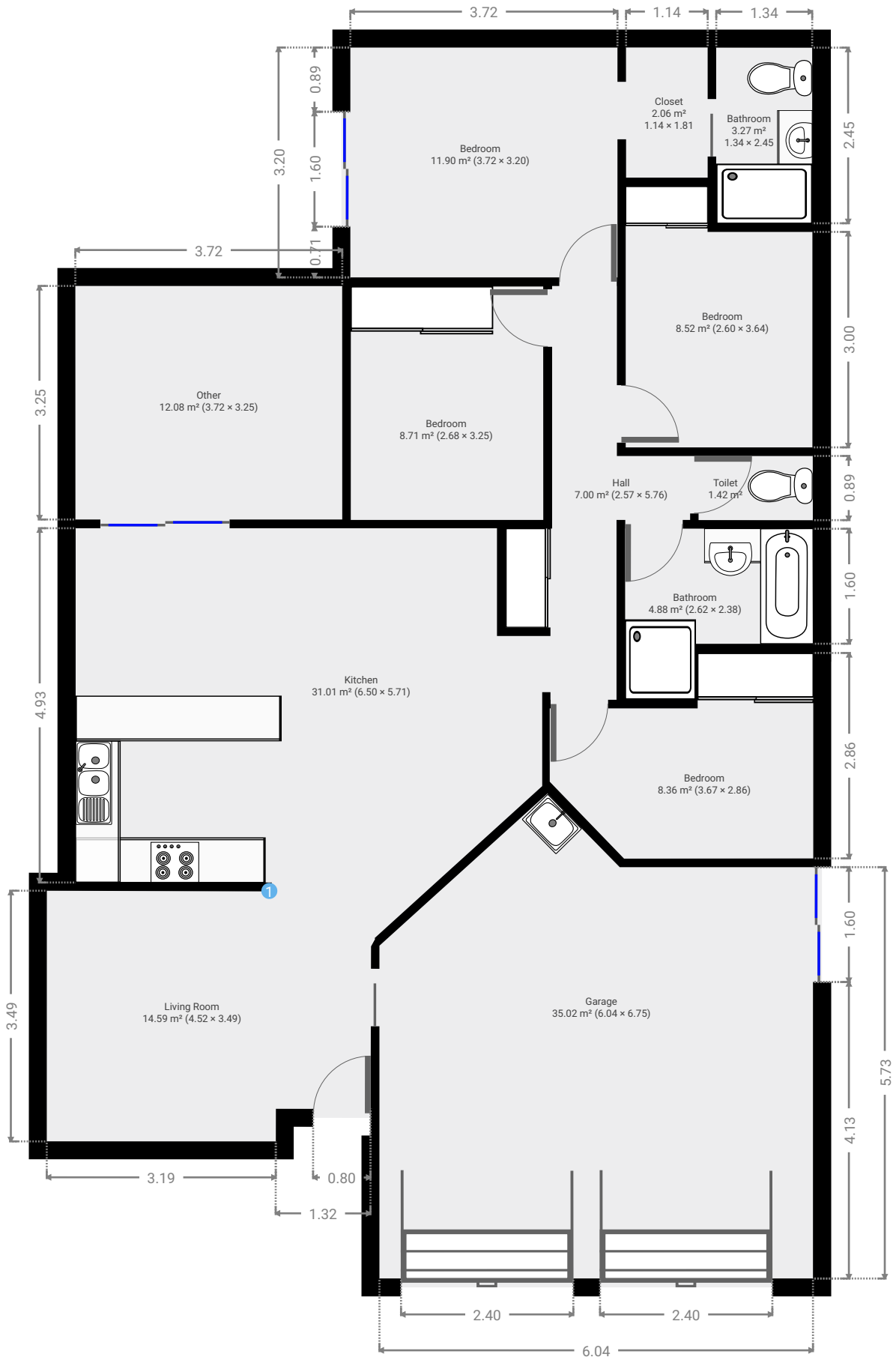

THIS FLOORPLAN IS PROVIDED WITHOUT WARRANTY OF ANY KIND. SENSOPIA DISCLAIMS ANY WARRANTY INCLUDING, WITHOUT LIMITATION, SATISFACTORY QUALITY OR ACCURACY OF DIMENSIONS.

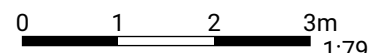

FLOORS: 1

▼ Bathroom  
Ground Floor

WIDTH: 2.62 m • LENGTH: 2.38 m  
AREA: 4.88 m<sup>2</sup> • PERIMETER: 9.99 m

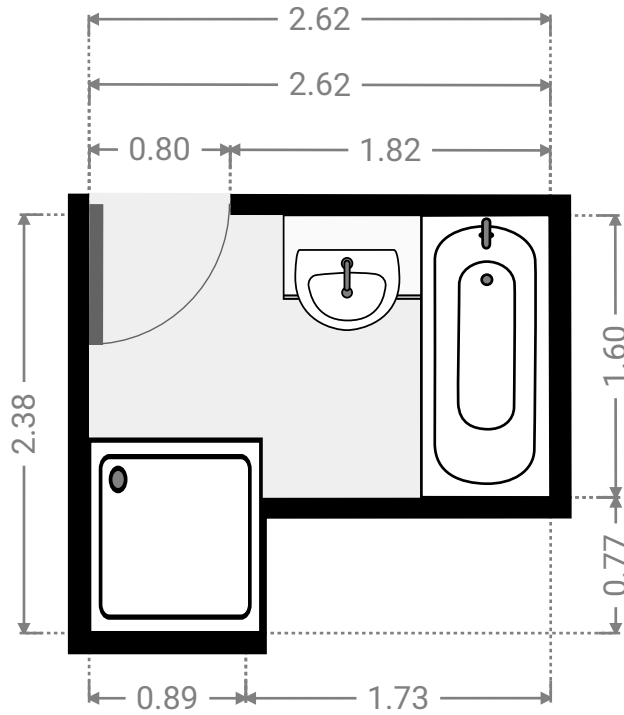
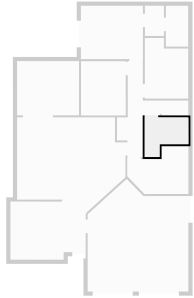

▼ Bathroom  
Ground Floor

WIDTH: 1.34 m • LENGTH: 2.45 m  
AREA: 3.27 m<sup>2</sup> • PERIMETER: 7.57 m

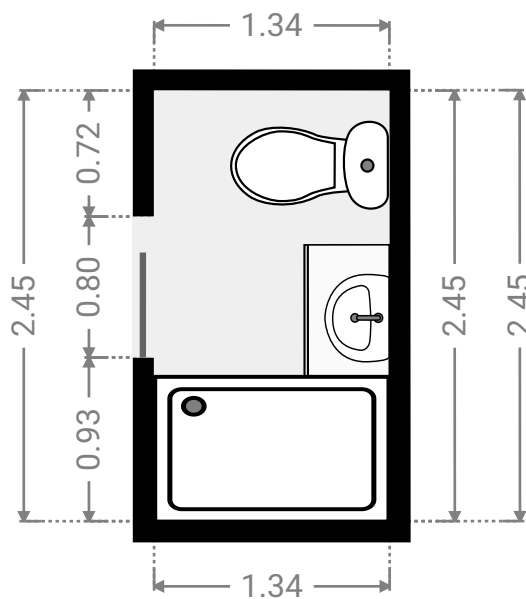
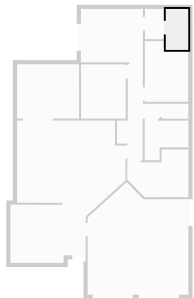

▼ **Bedroom**  
Ground Floor

WIDTH: 3.67 m • LENGTH: 2.86 m  
AREA: 8.36 m<sup>2</sup> • PERIMETER: 12.45 m

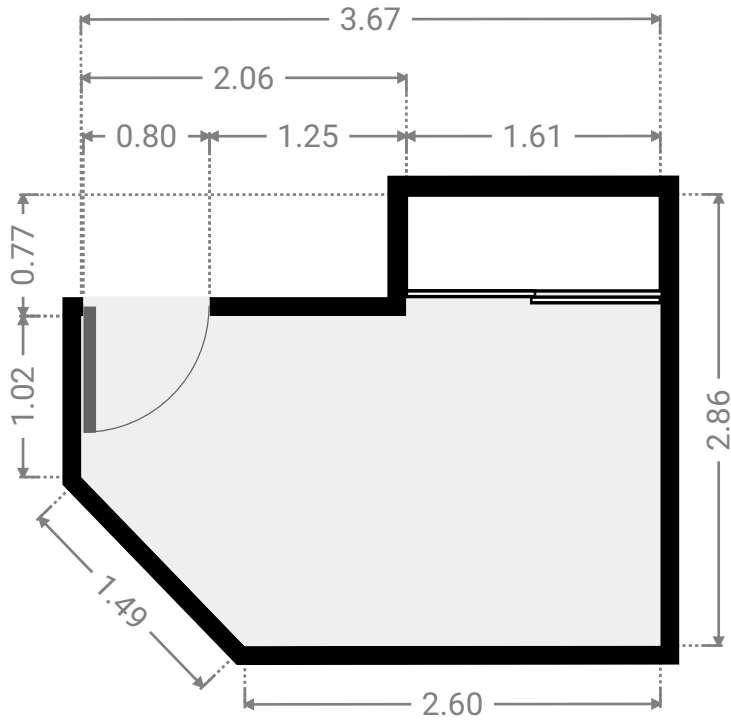
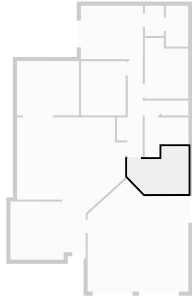

▼ **Bedroom**  
Ground Floor

WIDTH: 2.60 m • LENGTH: 3.64 m  
AREA: 8.52 m<sup>2</sup> • PERIMETER: 12.47 m

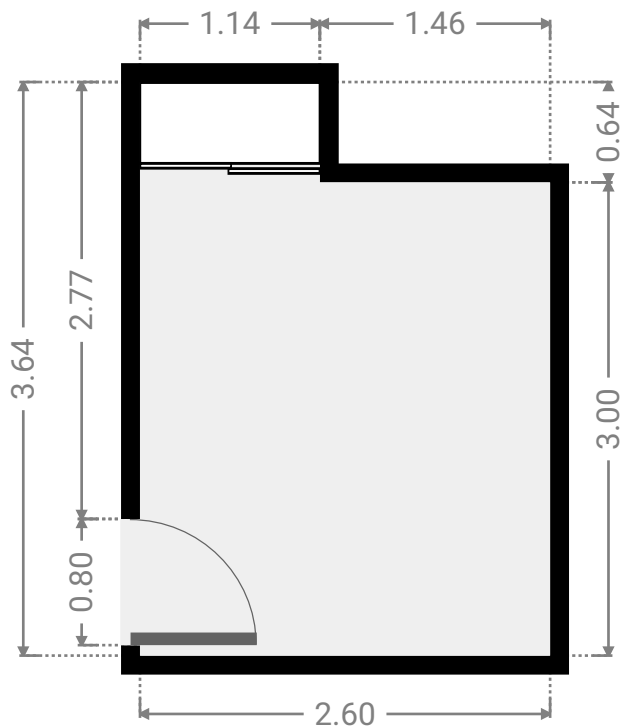
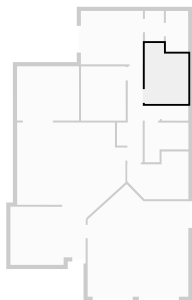

FLOORS: 1

▼ **Bedroom**  
Ground Floor

WIDTH: 2.68 m • LENGTH: 3.25 m  
AREA: 8.71 m<sup>2</sup> • PERIMETER: 11.86 m

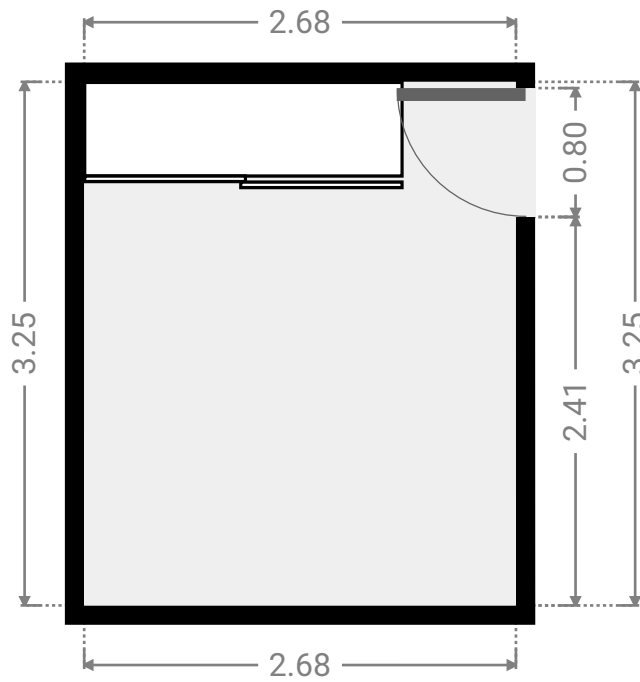
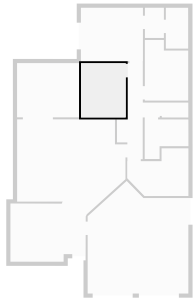

▼ **Bedroom**  
Ground Floor

WIDTH: 3.72 m • LENGTH: 3.20 m  
AREA: 11.90 m<sup>2</sup> • PERIMETER: 13.84 m

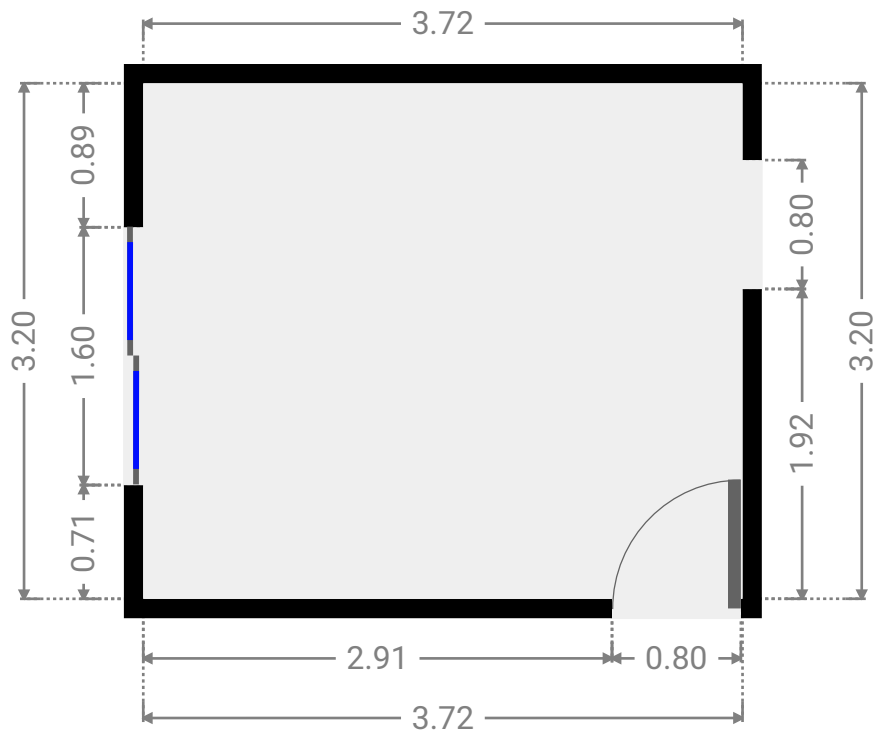
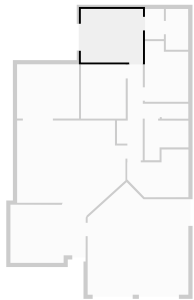

# 12 Kawana Close

FLOORS: 1

## ▼ Closet Ground Floor

WIDTH: 1.14 m • LENGTH: 1.81 m  
AREA: 2.06 m<sup>2</sup> • PERIMETER: 5.90 m

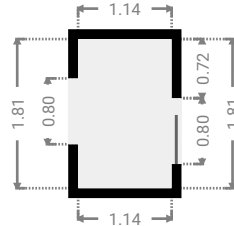
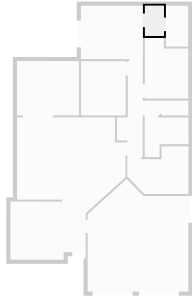

## ▼ Garage Ground Floor

WIDTH: 6.04 m • LENGTH: 6.75 m  
AREA: 35.02 m<sup>2</sup> • PERIMETER: 23.68 m

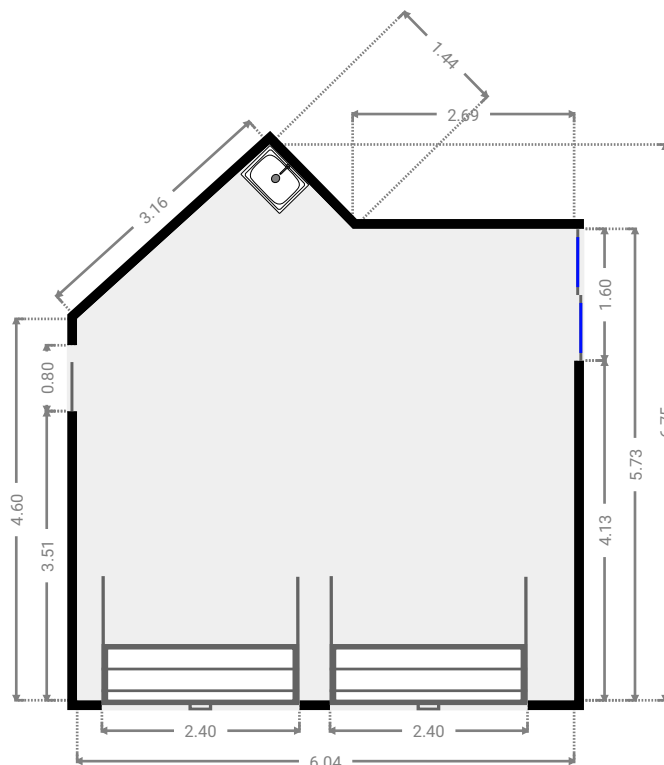
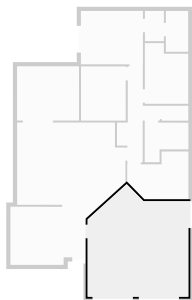

# 12 Kawana Close

FLOORS: 1



## ▼ Hall Ground Floor

WIDTH: 2.57 m • LENGTH: 5.76 m  
AREA: 7.00 m<sup>2</sup> • PERIMETER: 16.66 m

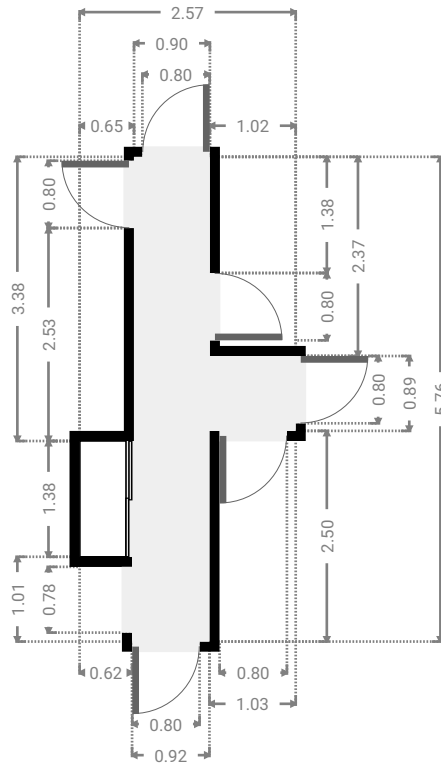
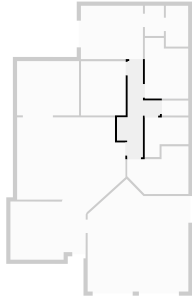

## ▼ Kitchen Ground Floor

WIDTH: 6.50 m • LENGTH: 5.71 m  
AREA: 31.01 m<sup>2</sup> • PERIMETER: 22.54 m

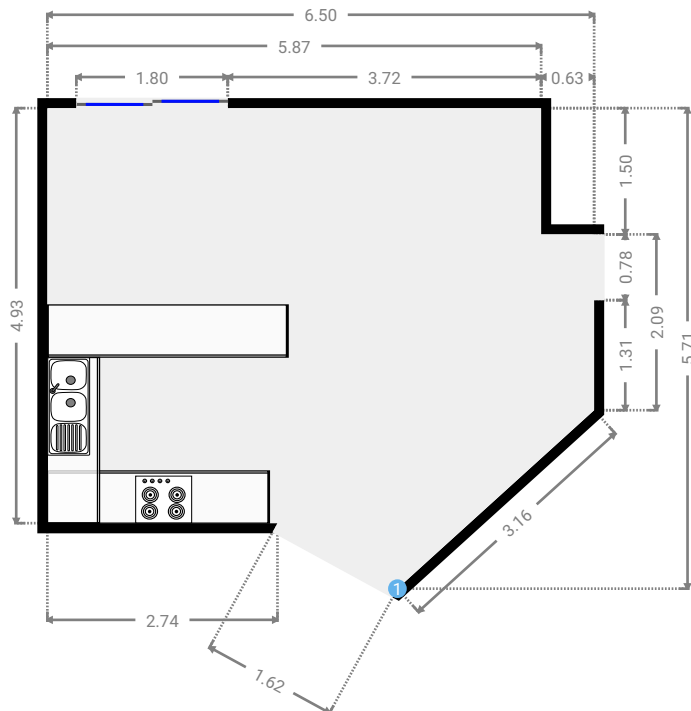
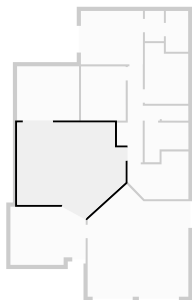

THIS FLOORPLAN IS PROVIDED WITHOUT WARRANTY OF ANY KIND. SENSOPIA DISCLAIMS ANY WARRANTY INCLUDING, WITHOUT LIMITATION, SATISFACTORY QUALITY OR ACCURACY OF DIMENSIONS.

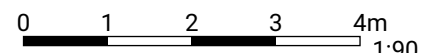

FLOORS: 1

## ▼ Living Room Ground Floor

WIDTH: 4.52 m • LENGTH: 3.49 m  
AREA: 14.59 m<sup>2</sup> • PERIMETER: 15.43 m

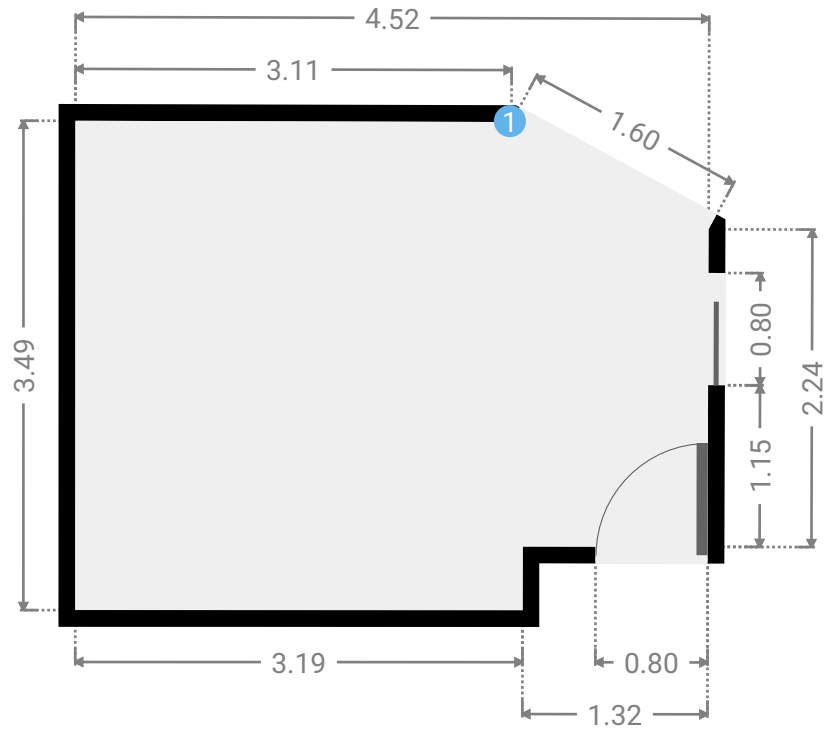
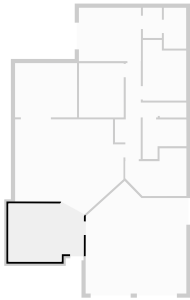

## ▼ Living Room/Ground Floor

### 1 OPENING

Height  
0.00 m





# 12 Kawana Close

FLOORS: 1

## ▼ Other Ground Floor

WIDTH: 3.72 m • LENGTH: 3.25 m  
AREA: 12.08 m<sup>2</sup> • PERIMETER: 13.94 m

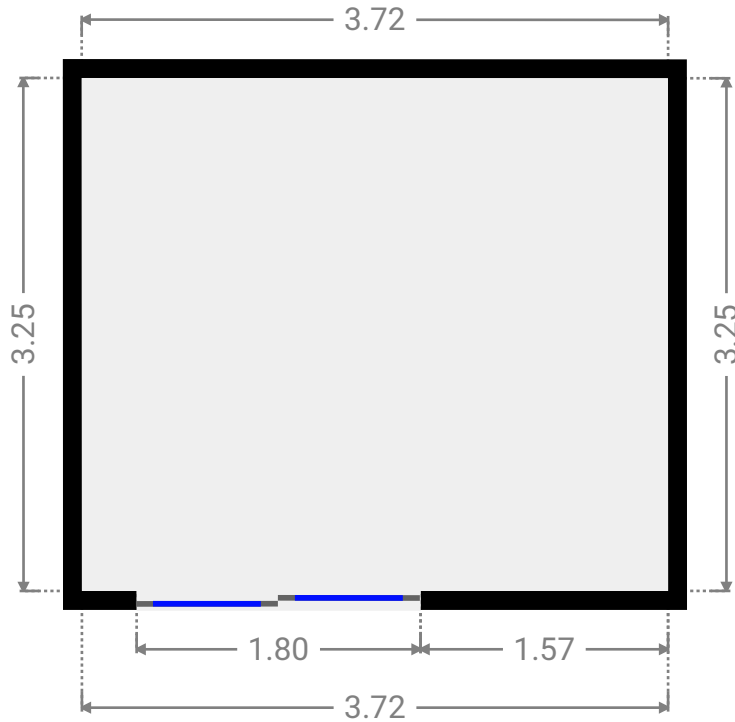
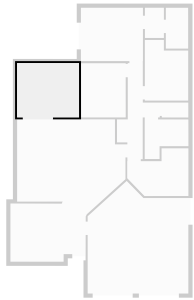

## ▼ Toilet Ground Floor

WIDTH: 1.59 m • LENGTH: 0.89 m  
AREA: 1.42 m<sup>2</sup> • PERIMETER: 4.97 m

