

114 Kerrigan Street

SUBMITTED BY

Ray White Rockhampton Casey
stockers@cqoz.com

CREATED ON

2019-12-20

Floors

1

▼ Ground Floor

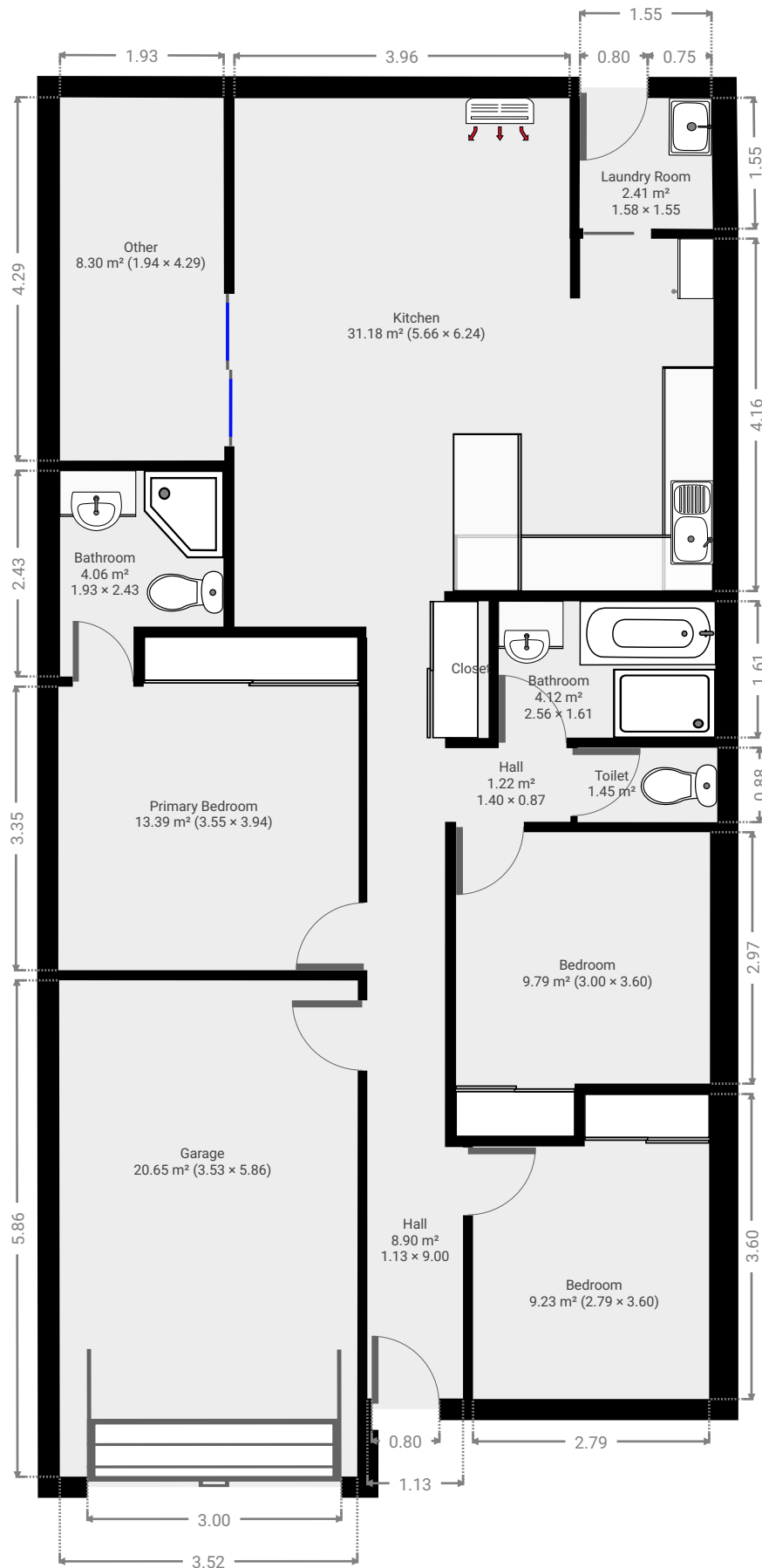

▼ **Bathroom**
Ground Floor

WIDTH: 1.93 m • LENGTH: 2.43 m
AREA: 4.06 m² • PERIMETER: 8.72 m

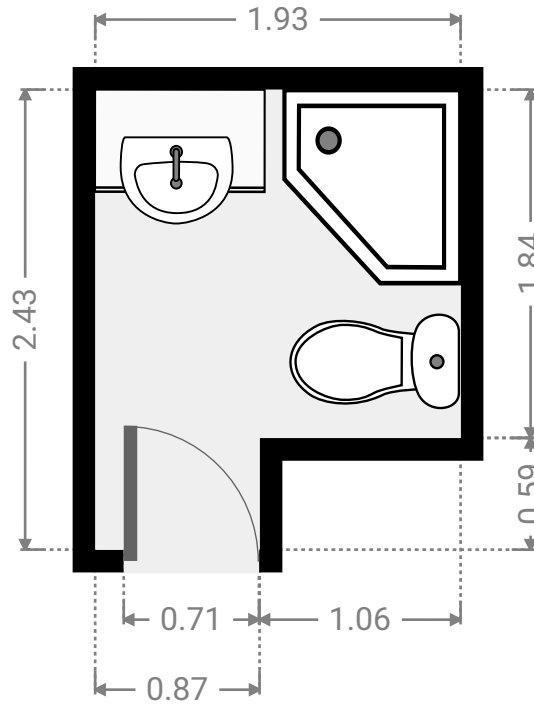
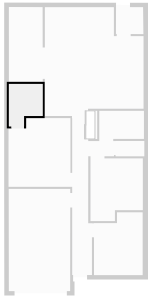

▼ **Bathroom**
Ground Floor

WIDTH: 2.56 m • LENGTH: 1.61 m
AREA: 4.12 m² • PERIMETER: 8.34 m

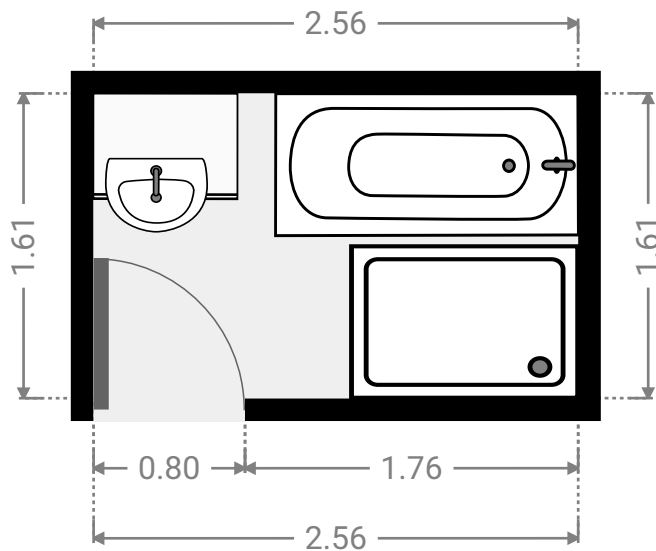
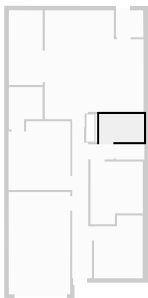

FLOORS: 1

▼ **Bedroom**
Ground Floor

WIDTH: 2.79 m • LENGTH: 3.60 m
AREA: 9.23 m² • PERIMETER: 12.79 m

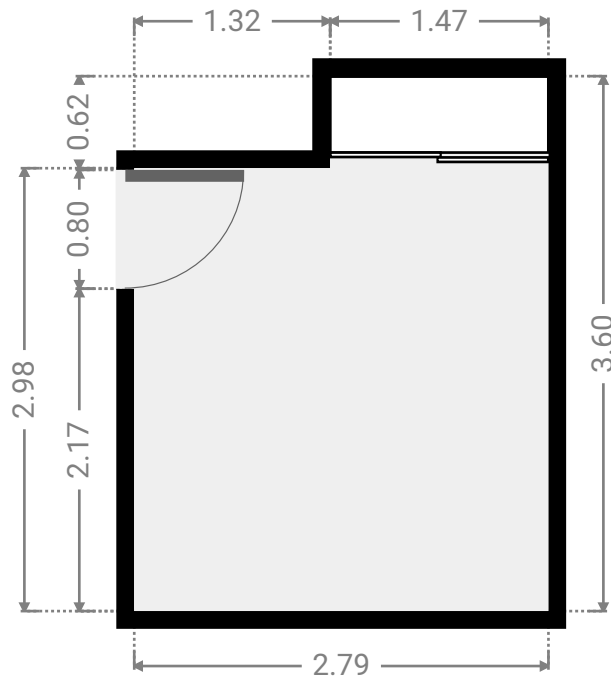

▼ **Bedroom**
Ground Floor

WIDTH: 3.00 m • LENGTH: 3.60 m
AREA: 9.79 m² • PERIMETER: 13.19 m

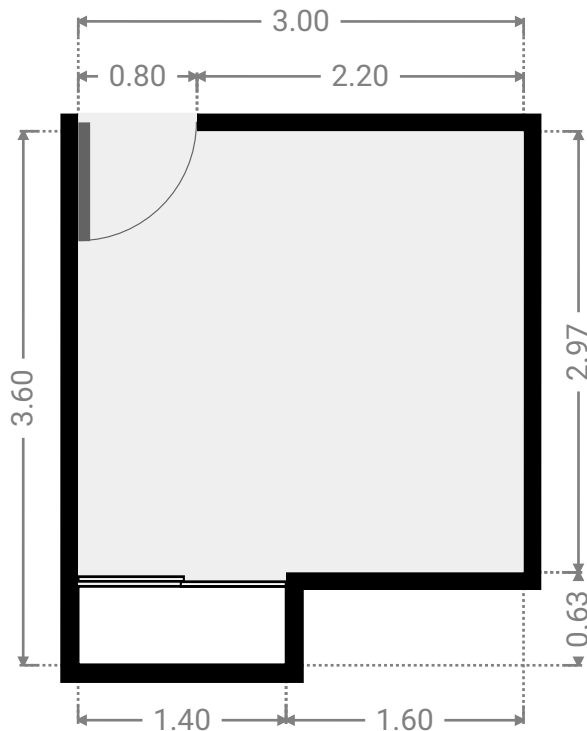
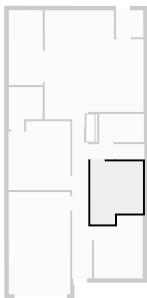

FLOORS: 1

▼ **Closet**
Ground Floor

WIDTH: 0.41 m • LENGTH: 1.61 m
AREA: 0.66 m² • PERIMETER: 4.05 m

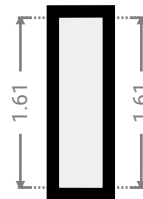
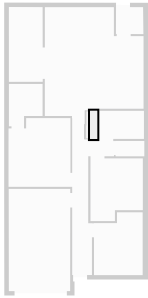

▼ **Garage**
Ground Floor

WIDTH: 3.53 m • LENGTH: 5.86 m
AREA: 20.65 m² • PERIMETER: 18.77 m

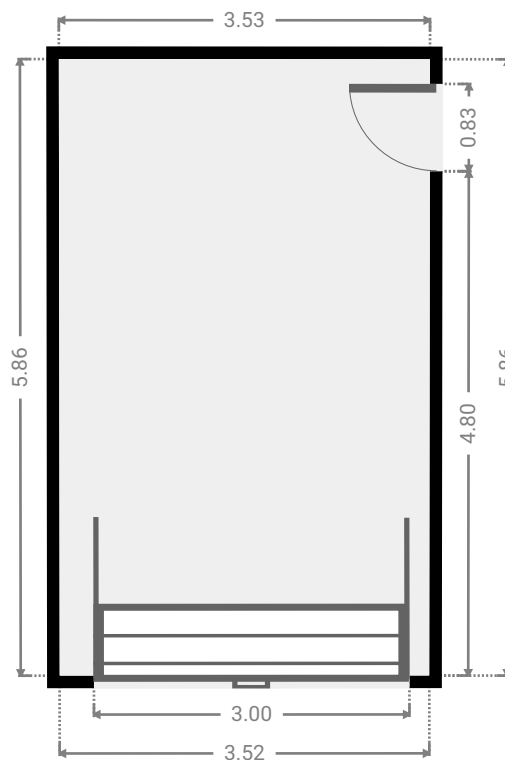
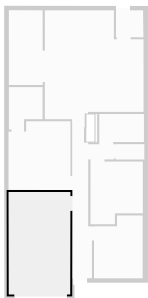

FLOORS: 1

▼ Hall
Ground Floor

WIDTH: 1.13 m • LENGTH: 9.00 m
AREA: 8.90 m² • PERIMETER: 20.26 m

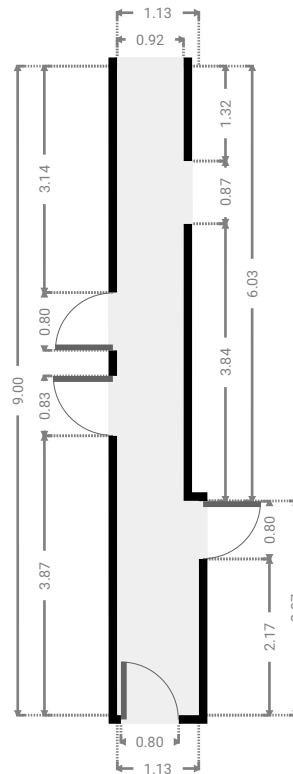
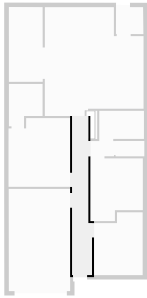

▼ Hall
Ground Floor

WIDTH: 1.40 m • LENGTH: 0.87 m
AREA: 1.22 m² • PERIMETER: 4.54 m

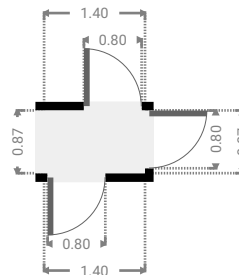
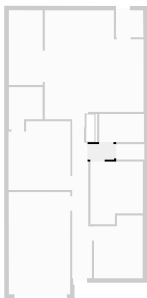

▼ Kitchen
Ground Floor

WIDTH: 5.66 m • LENGTH: 6.24 m
AREA: 31.18 m² • PERIMETER: 23.80 m

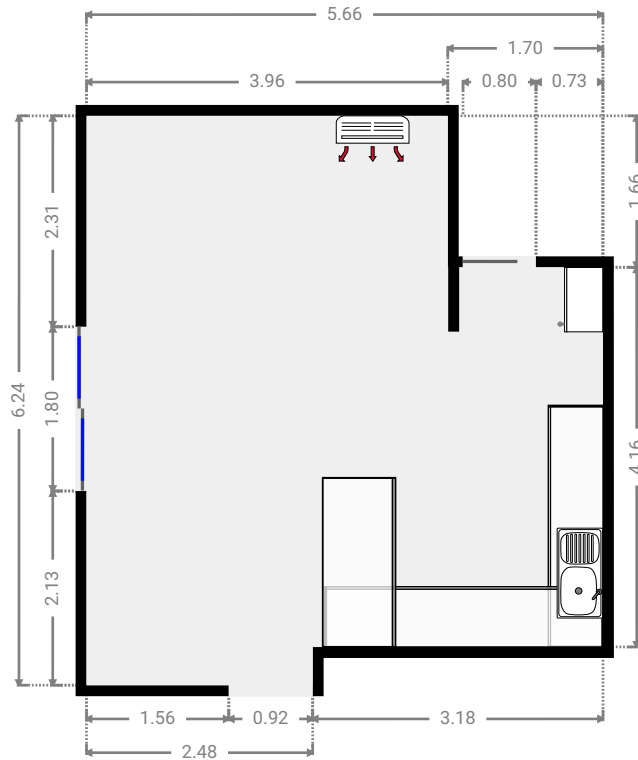
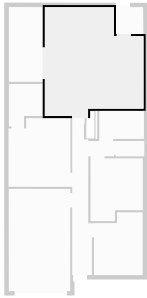

▼ Laundry Room
Ground Floor

WIDTH: 1.58 m • LENGTH: 1.55 m
AREA: 2.41 m² • PERIMETER: 6.21 m

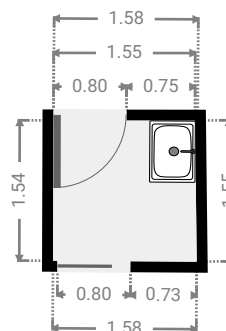
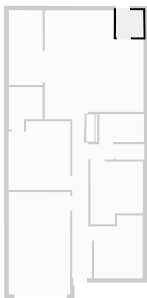

▼ **Other**
Ground Floor

WIDTH: 1.94 m • LENGTH: 4.29 m
AREA: 8.30 m² • PERIMETER: 12.45 m

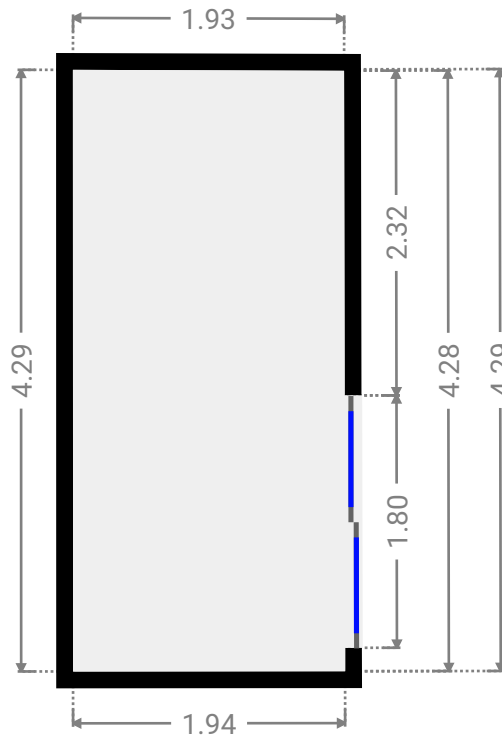
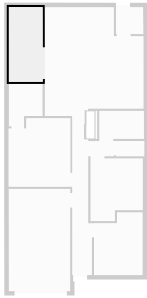

▼ **Primary Bedroom**
Ground Floor

WIDTH: 3.55 m • LENGTH: 3.94 m
AREA: 13.39 m² • PERIMETER: 14.98 m

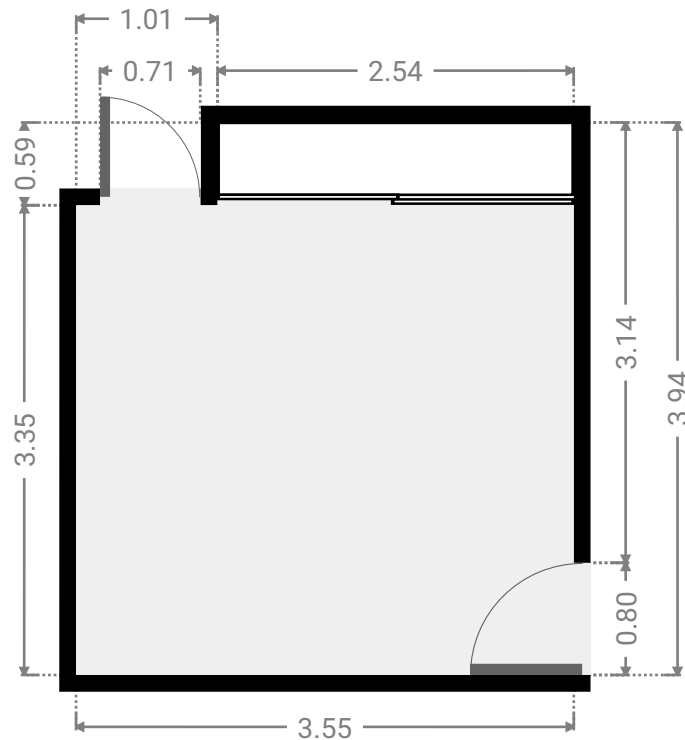
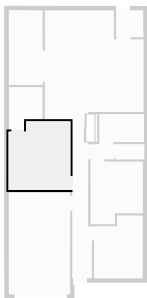

▼ Toilet
Ground Floor

WIDTH: 1.65 m • LENGTH: 0.88 m
AREA: 1.45 m² • PERIMETER: 5.06 m

