

# 112 Grosskoph Street

Created on  
2021-07-20

Floors  
2

▼ Ground Floor

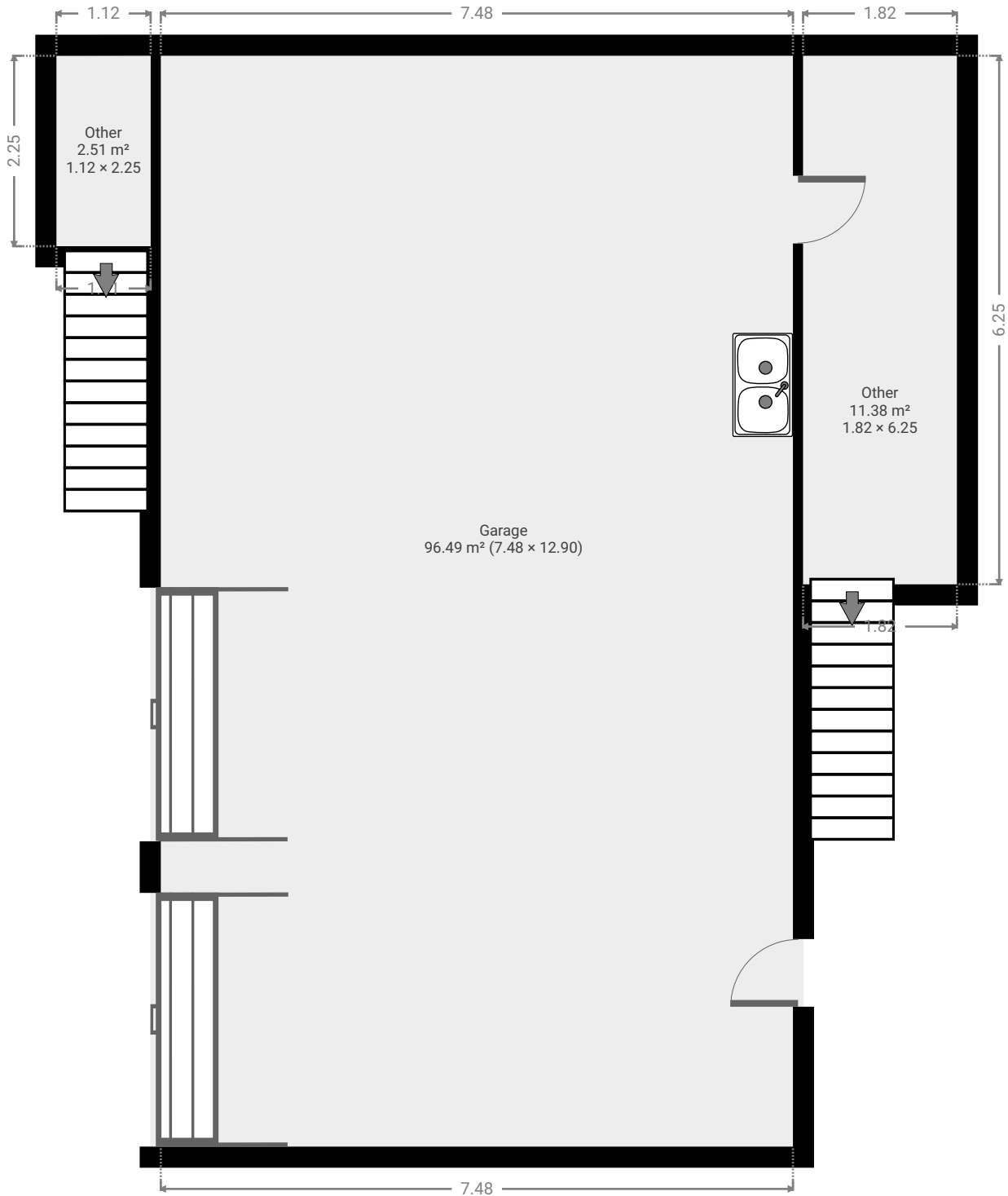

▼ **Garage**  
Ground Floor

WIDTH: 12.90 m • LENGTH: 7.48 m  
AREA: 96.49 m<sup>2</sup> • PERIMETER: 40.76 m

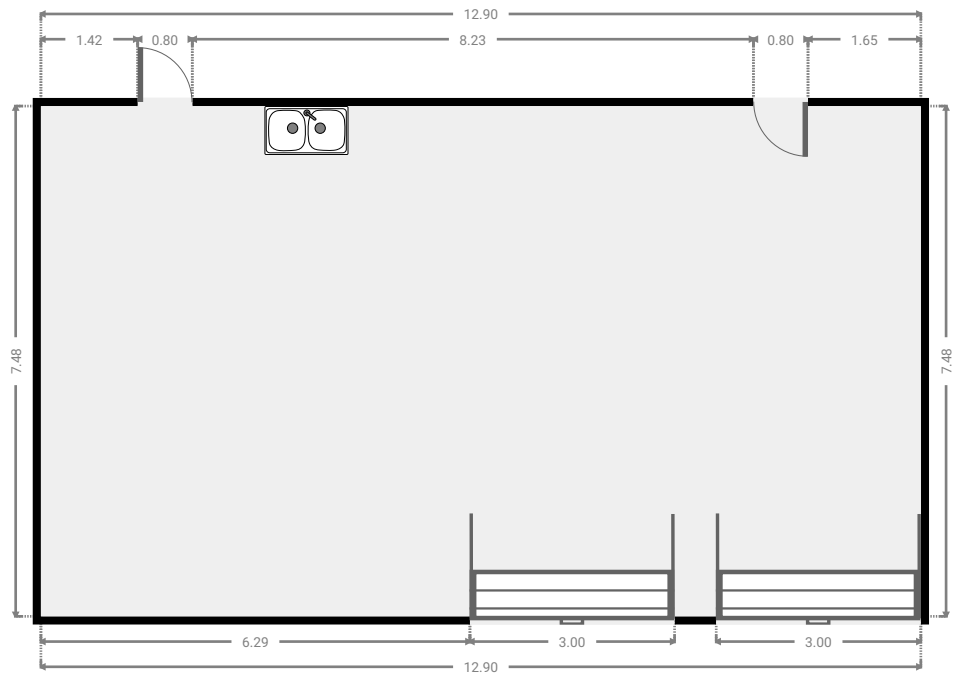
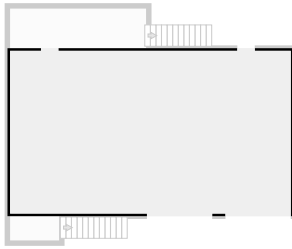

▼ **Other**  
Ground Floor

WIDTH: 6.25 m • LENGTH: 1.82 m  
AREA: 11.38 m<sup>2</sup> • PERIMETER: 16.14 m

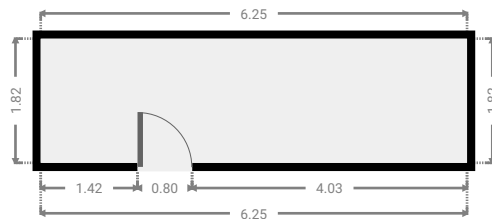
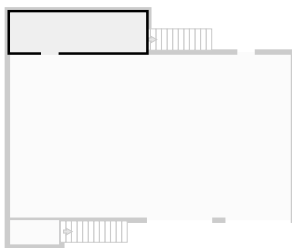

▼ Other  
Ground Floor

WIDTH: 2.25 m • LENGTH: 1.12 m  
AREA: 2.51 m<sup>2</sup> • PERIMETER: 6.73 m

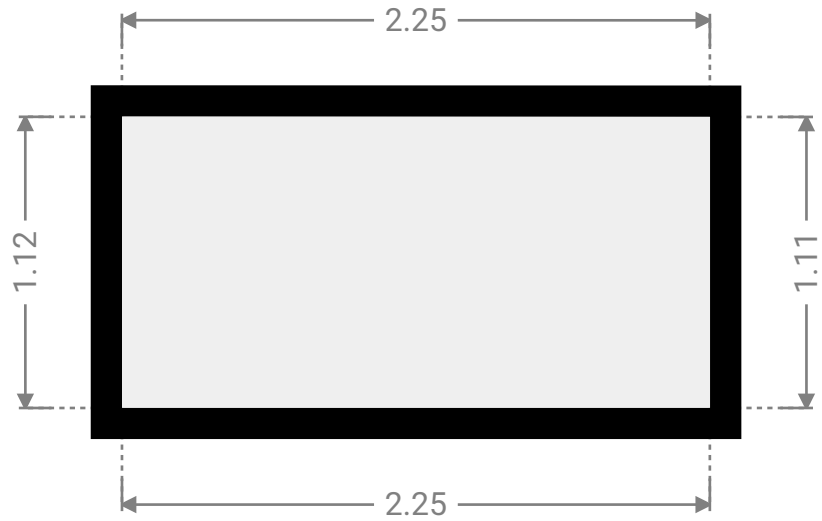
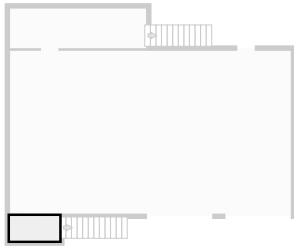

▼ 1st Floor

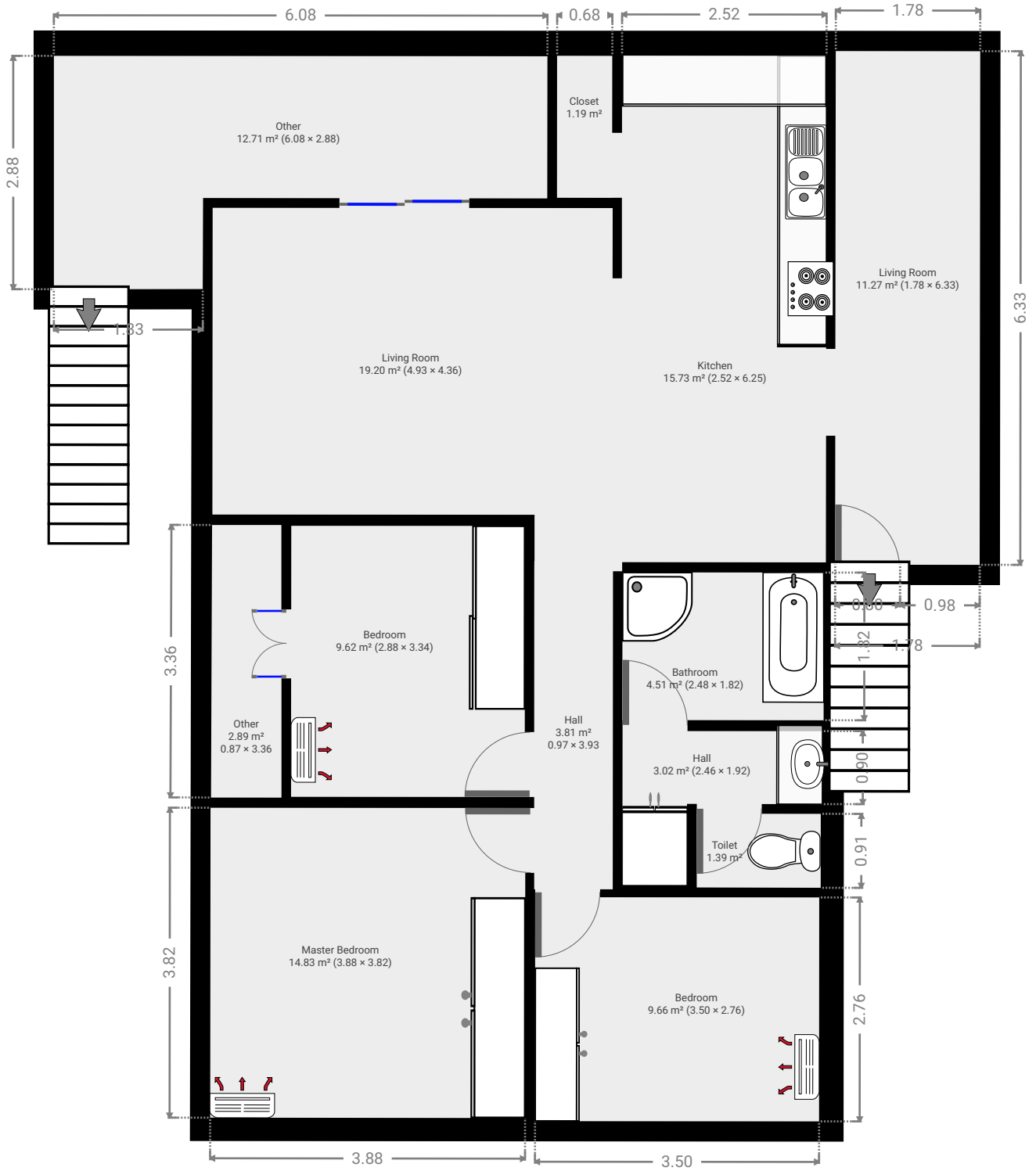

▼ **Living Room**  
1st Floor

WIDTH: 4.36 m • LENGTH: 4.93 m  
AREA: 19.20 m<sup>2</sup> • PERIMETER: 18.58 m

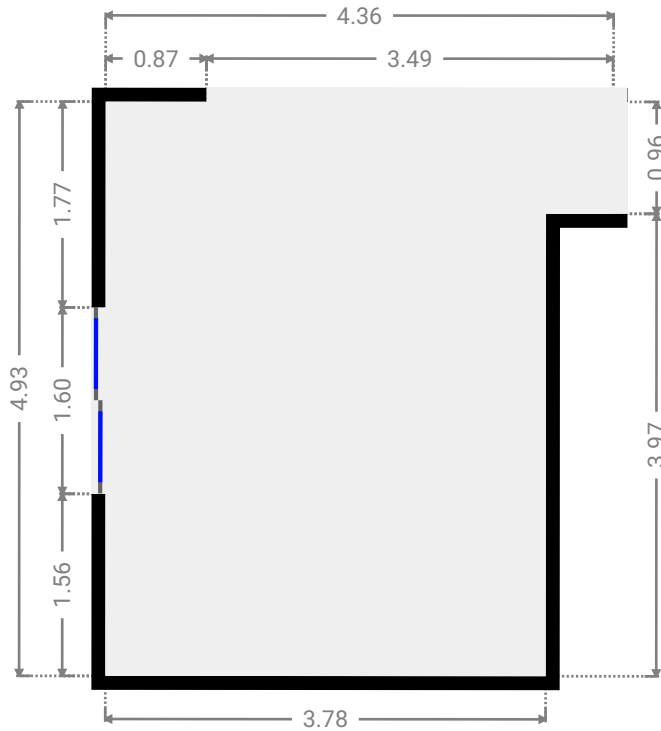
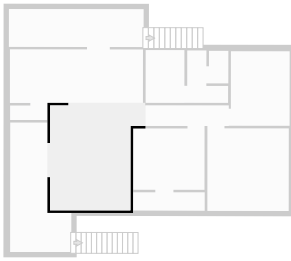

▼ **Kitchen**  
1st Floor

WIDTH: 6.25 m • LENGTH: 2.52 m  
AREA: 15.73 m<sup>2</sup> • PERIMETER: 17.54 m

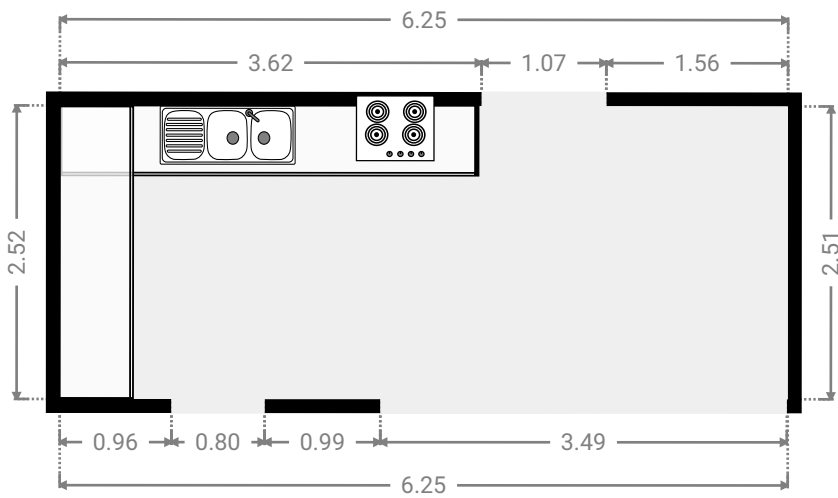
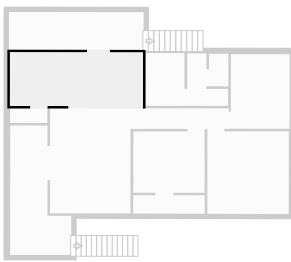

▼ **Closet**  
1st Floor

WIDTH: 1.75 m • LENGTH: 0.68 m  
AREA: 1.19 m<sup>2</sup> • PERIMETER: 4.86 m

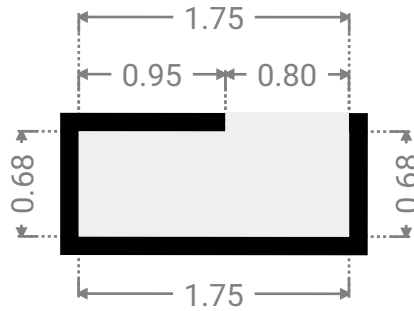

▼ **Hall**  
1st Floor

WIDTH: 3.93 m • LENGTH: 0.97 m  
AREA: 3.81 m<sup>2</sup> • PERIMETER: 9.80 m

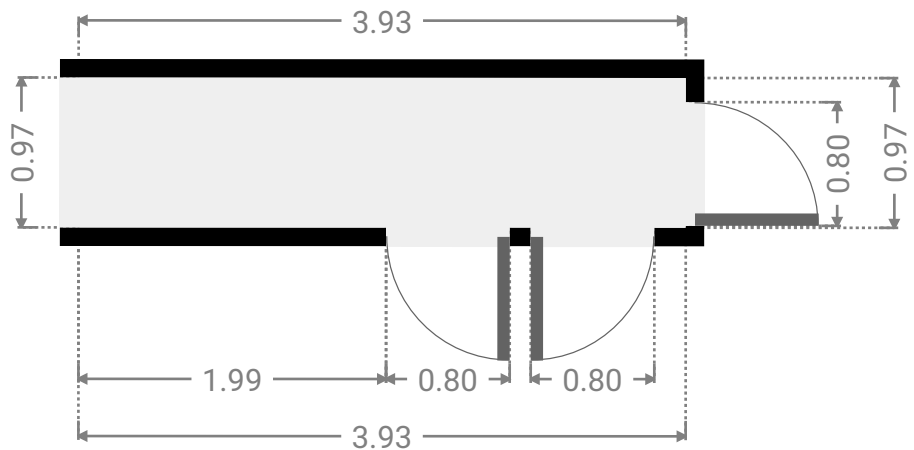

▼ **Bedroom**  
1st Floor

WIDTH: 3.34 m • LENGTH: 2.88 m  
AREA: 9.62 m<sup>2</sup> • PERIMETER: 12.44 m

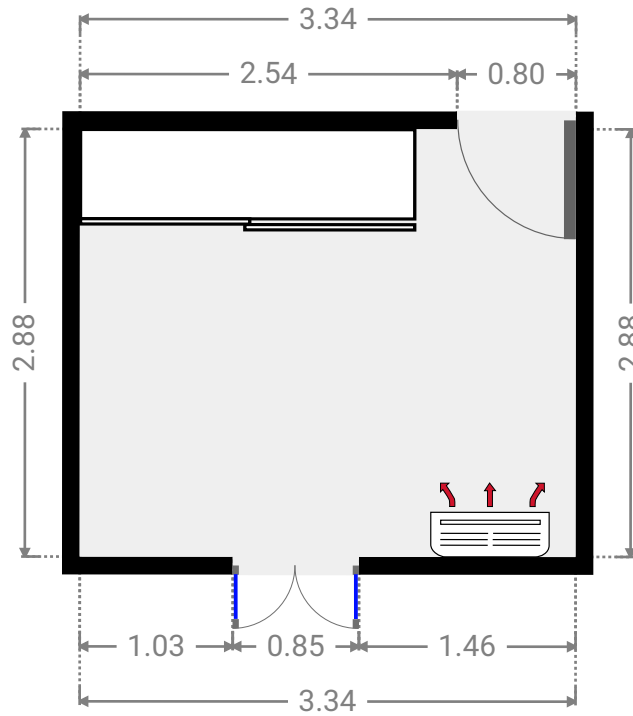
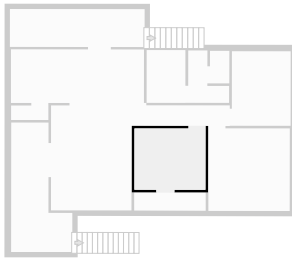

▼ **Bathroom**  
1st Floor

WIDTH: 1.82 m • LENGTH: 2.48 m  
AREA: 4.51 m<sup>2</sup> • PERIMETER: 8.60 m

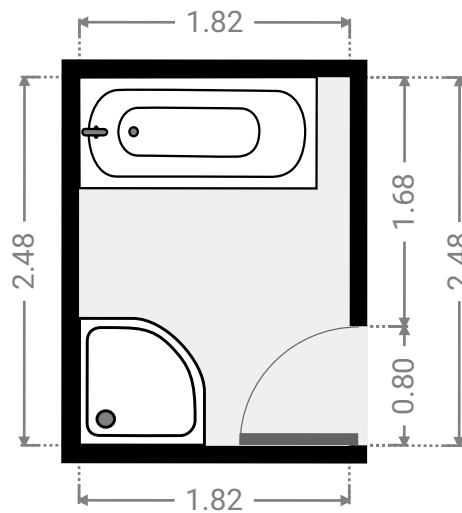
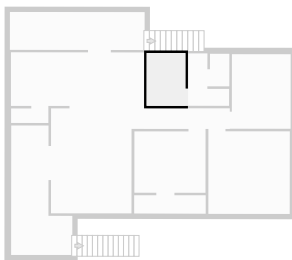



▼ **Hall**  
1st Floor

WIDTH: 1.92 m • LENGTH: 2.46 m  
AREA: 3.02 m<sup>2</sup> • PERIMETER: 8.76 m

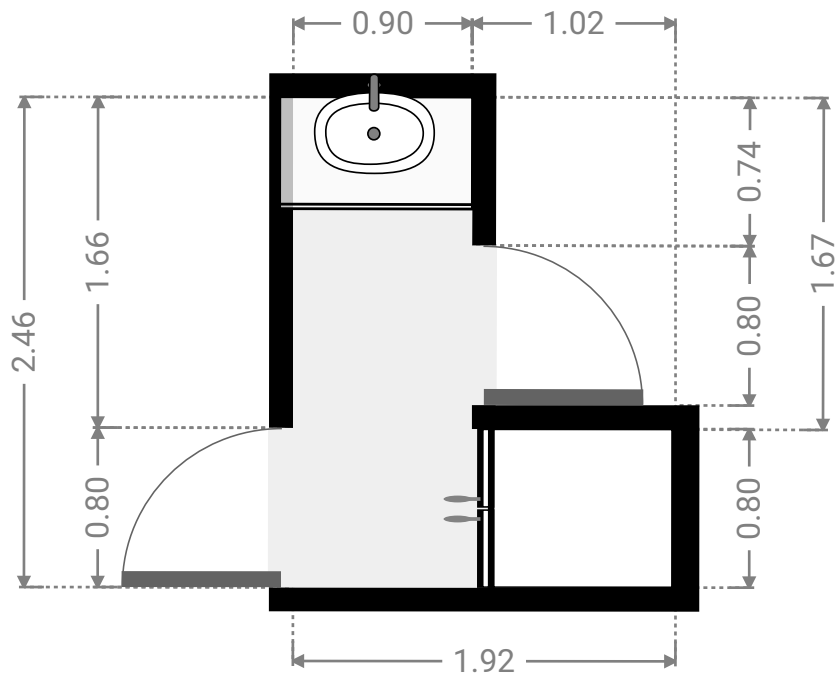
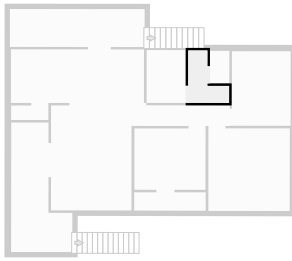

▼ **Toilet**  
1st Floor

WIDTH: 0.91 m • LENGTH: 1.53 m  
AREA: 1.39 m<sup>2</sup> • PERIMETER: 4.88 m

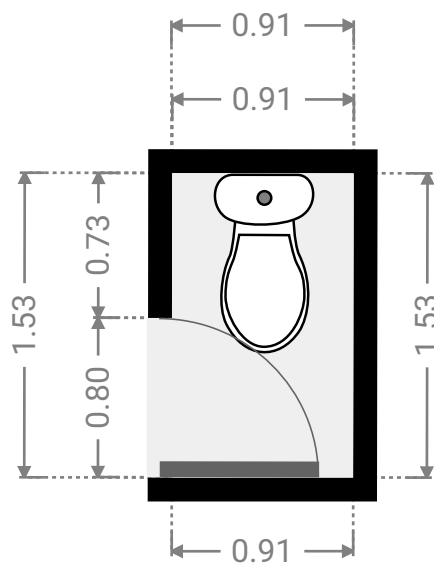

▼ **Bedroom**  
1st Floor

WIDTH: 2.76 m • LENGTH: 3.50 m  
AREA: 9.66 m<sup>2</sup> • PERIMETER: 12.52 m

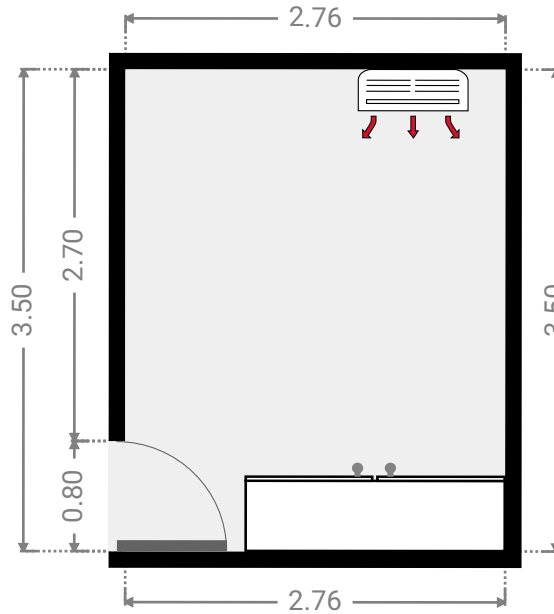
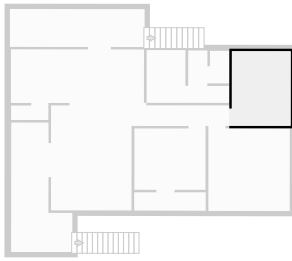

▼ **Master Bedroom**  
1st Floor

WIDTH: 3.82 m • LENGTH: 3.88 m  
AREA: 14.83 m<sup>2</sup> • PERIMETER: 15.40 m

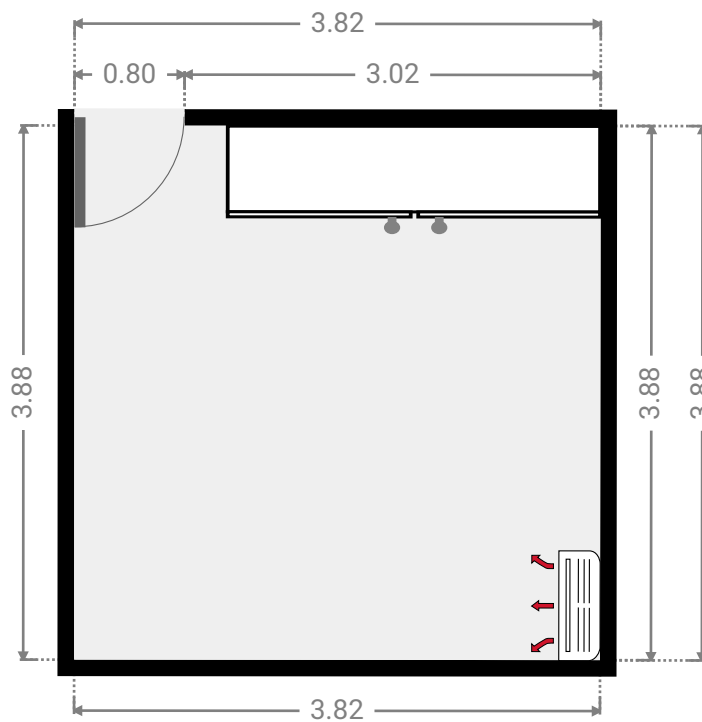
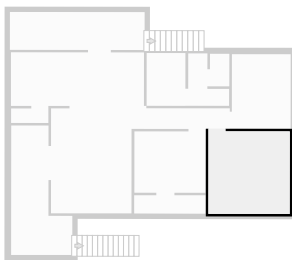

▼ **Living Room**  
1st Floor

WIDTH: 6.33 m • LENGTH: 1.78 m  
AREA: 11.27 m<sup>2</sup> • PERIMETER: 16.22 m

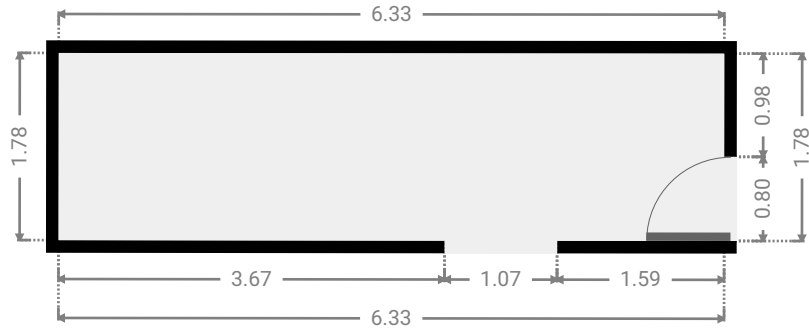
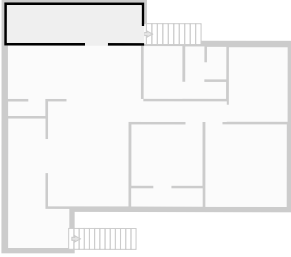

▼ **Other**  
1st Floor

WIDTH: 2.88 m • LENGTH: 6.08 m  
AREA: 12.71 m<sup>2</sup> • PERIMETER: 17.91 m

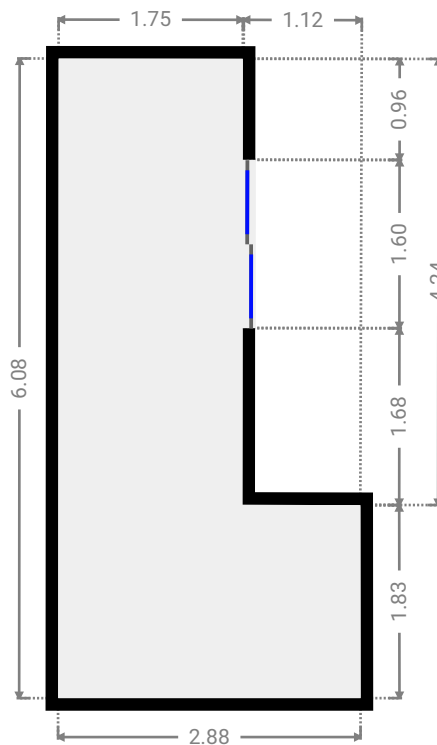
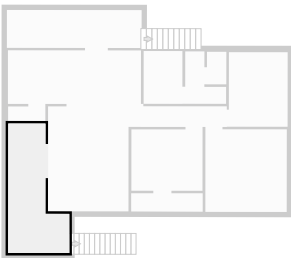

▼ Other  
1st Floor

WIDTH: 3.36 m • LENGTH: 0.87 m  
AREA: 2.89 m<sup>2</sup> • PERIMETER: 8.44 m

