

# 11 Wiseman Street

Created on  
2021-07-01

Floors  
1

▼ Ground Floor

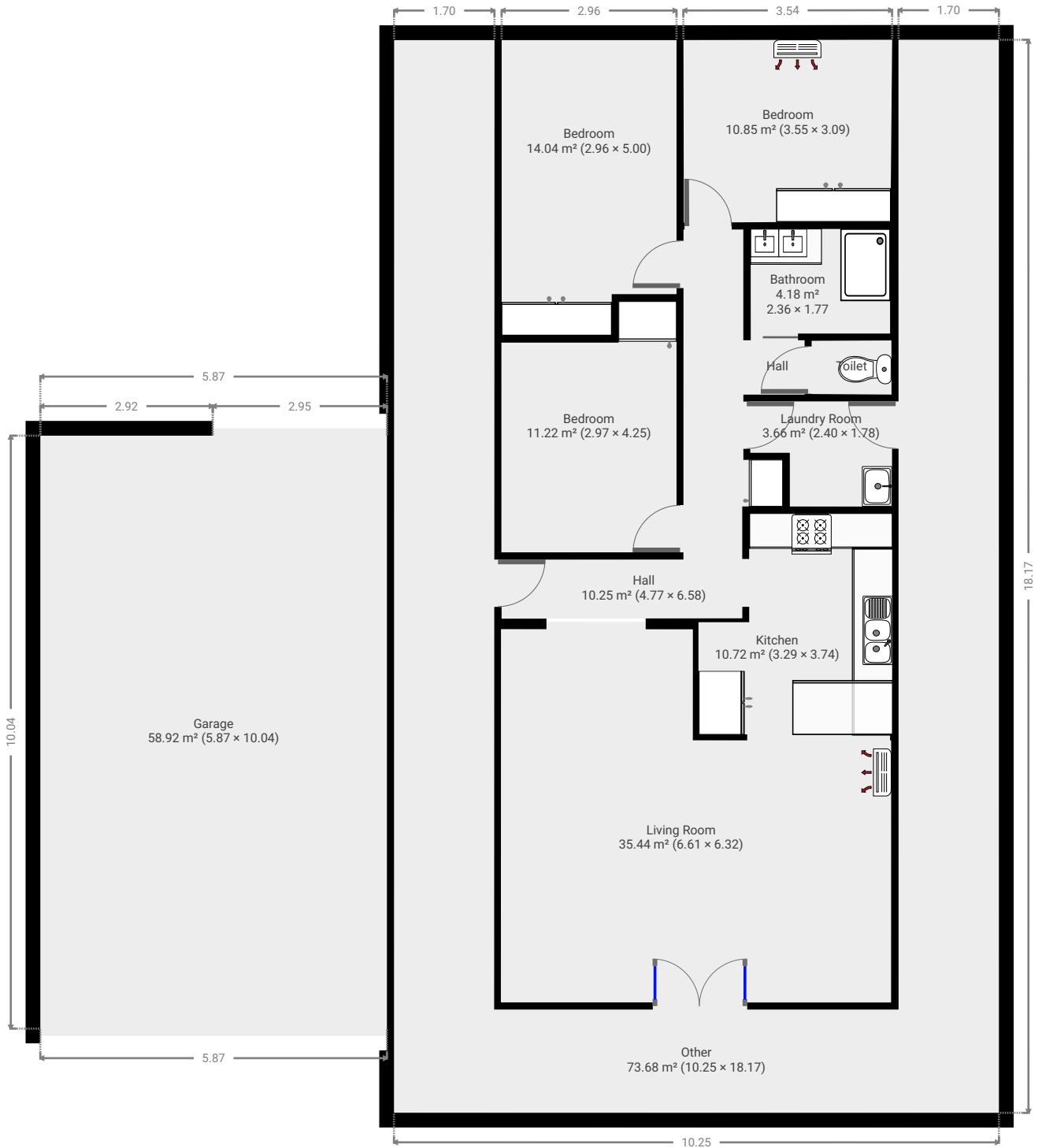

▼ Living Room  
Ground Floor

WIDTH: 6.61 m • LENGTH: 6.32 m  
AREA: 35.44 m<sup>2</sup> • PERIMETER: 25.86 m

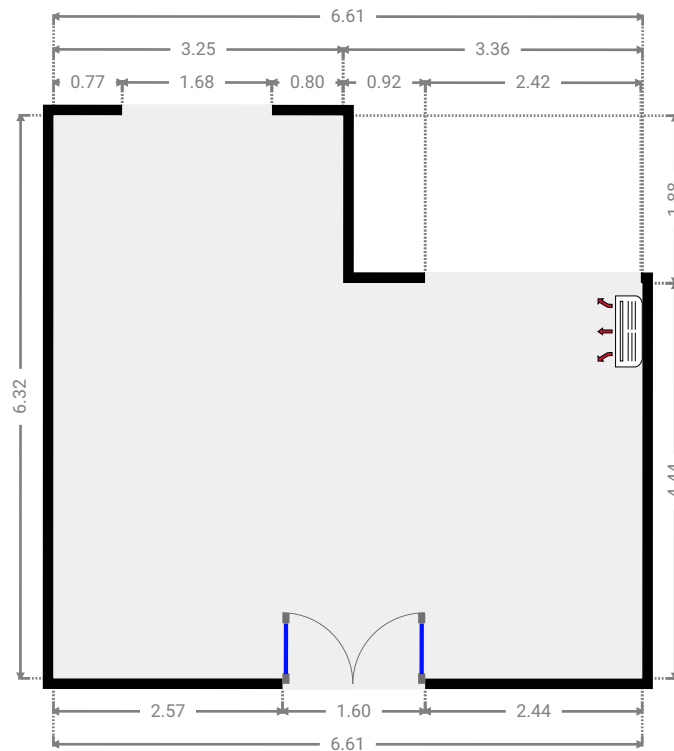
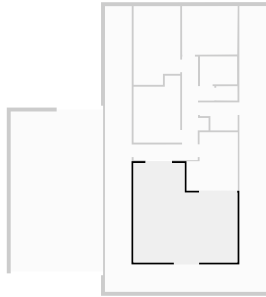

▼ Kitchen  
Ground Floor

WIDTH: 3.29 m • LENGTH: 3.74 m  
AREA: 10.72 m<sup>2</sup> • PERIMETER: 14.06 m

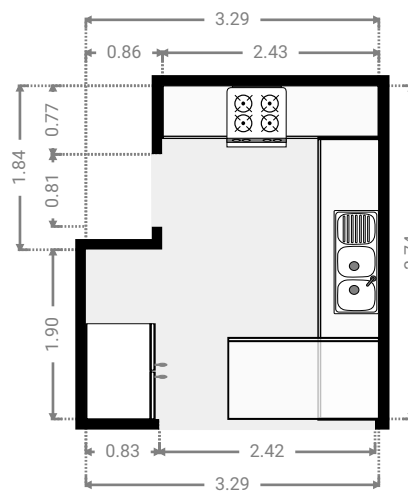
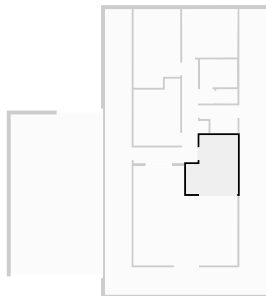



▼ **Laundry Room**  
Ground Floor

WIDTH: 2.40 m • LENGTH: 1.78 m  
AREA: 3.66 m<sup>2</sup> • PERIMETER: 8.36 m

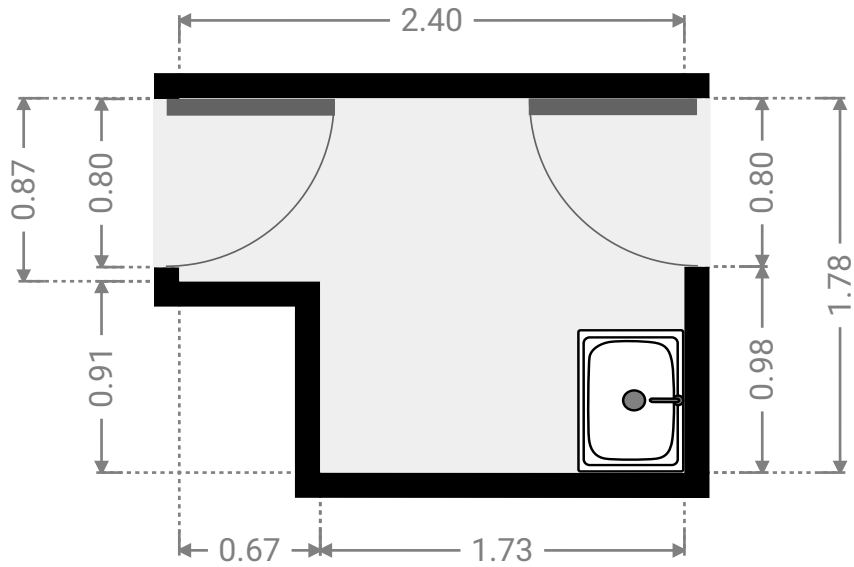
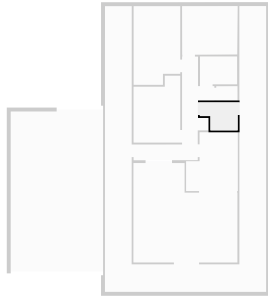

▼ **Hall**  
Ground Floor

WIDTH: 0.92 m • LENGTH: 0.92 m  
AREA: 0.85 m<sup>2</sup> • PERIMETER: 3.68 m

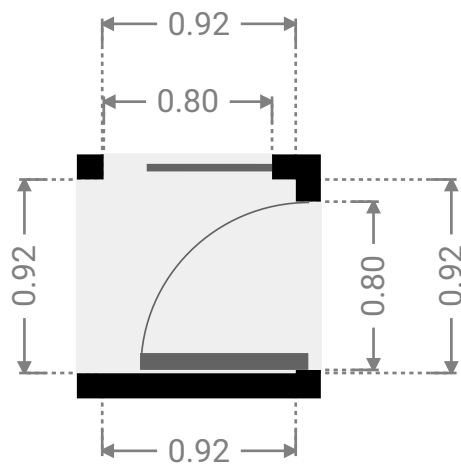
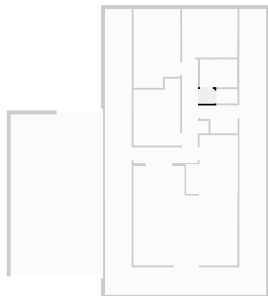

▼ **Toilet**  
Ground Floor

WIDTH: 1.35 m • LENGTH: 0.92 m  
AREA: 1.23 m<sup>2</sup> • PERIMETER: 4.52 m

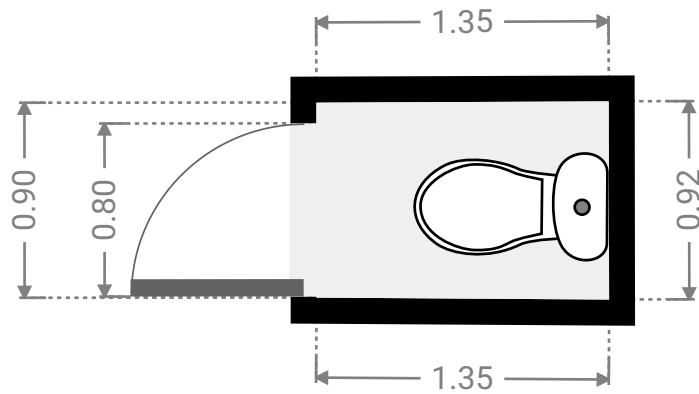

▼ **Bathroom**  
Ground Floor

WIDTH: 2.36 m • LENGTH: 1.77 m  
AREA: 4.18 m<sup>2</sup> • PERIMETER: 8.26 m

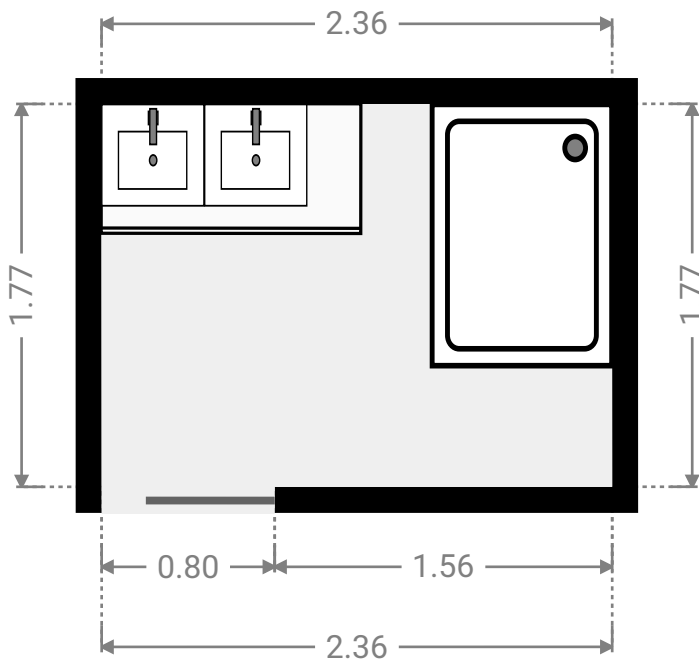
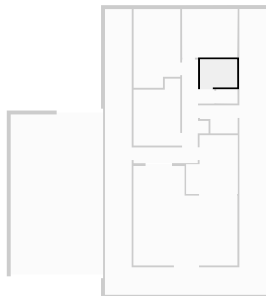

▼ **Bedroom**  
Ground Floor

WIDTH: 2.96 m • LENGTH: 5.00 m  
AREA: 14.04 m<sup>2</sup> • PERIMETER: 15.92 m

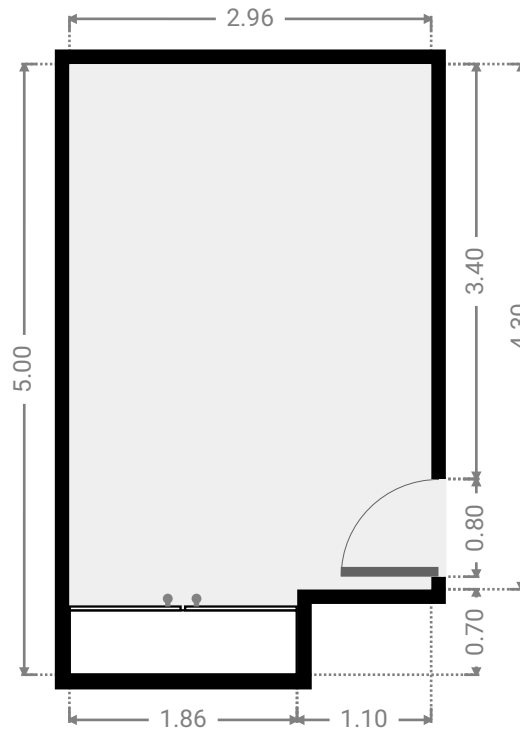
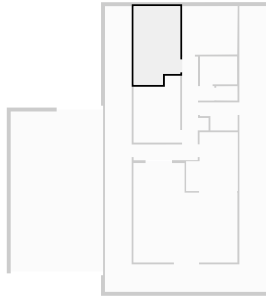

▼ **Bedroom**  
Ground Floor

WIDTH: 3.55 m • LENGTH: 3.09 m  
AREA: 10.85 m<sup>2</sup> • PERIMETER: 13.20 m

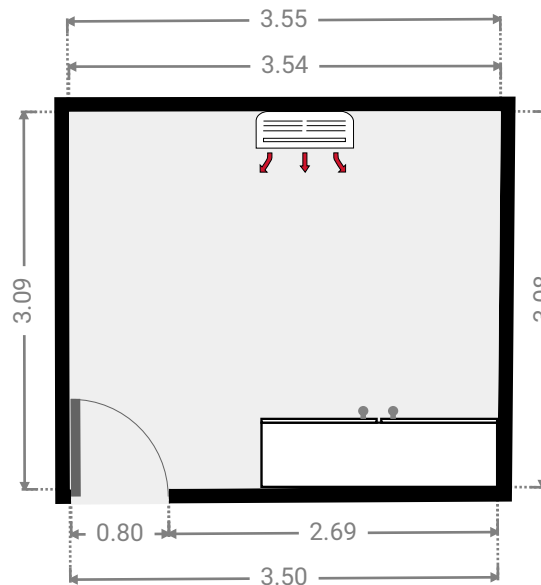
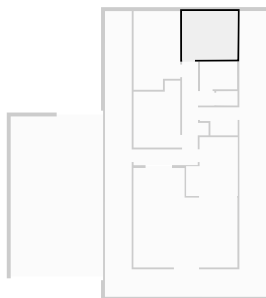

▼ Other  
Ground Floor

WIDTH: 10.25 m • LENGTH: 18.17 m  
AREA: 73.68 m<sup>2</sup> • PERIMETER: 89.65 m

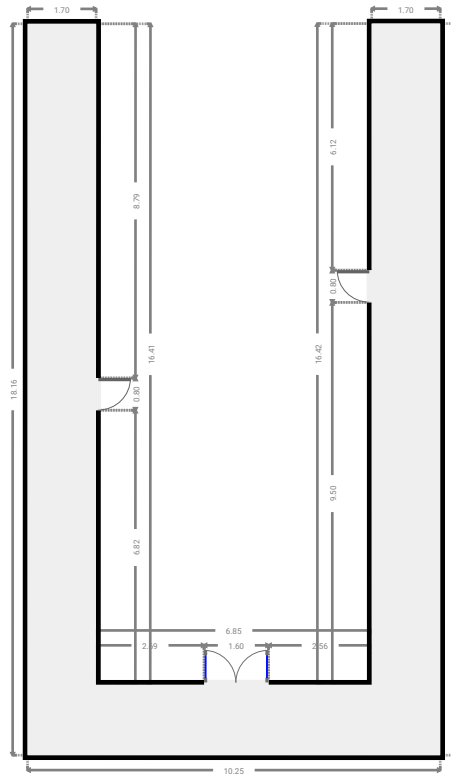
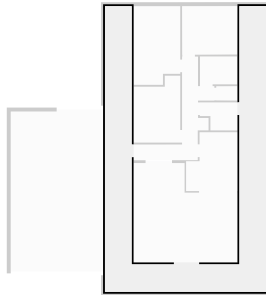

▼ Garage  
Ground Floor

WIDTH: 5.87 m • LENGTH: 10.04 m  
AREA: 58.92 m<sup>2</sup> • PERIMETER: 31.82 m

